



## General Description

The AF1880 is a linear LED driver. The application of high bright LED is widely used for general illumination.

The AF1880 maximum output current is 50mA. Typical variations is  $\pm 2\%$  in  $V_{IN} = 6 \sim 500V$  input voltage range and  $-40 \sim 85^\circ C$  temperature range. Ground current is approximately  $32\mu A$ , from zero to maximum loading conditions at  $T_A=25^\circ C$ .

Built-in thermal shutdown protection against any fault conditions. The output current can be setting by place a resistor at  $V_{CS}$  pin. For ease of application, the AF1880 comes in the popular 3-pin SOT-223.

## Features

- 6~500V wide input voltage range.
- Least external component.
- Typical ground current is  $32\mu A$ .
- $\pm 2\%$  accuracy  $V_{CS}$  voltage.
- Can be paralleled for higher current
- Thermal Shutdown Protection.
- User TRIAC dimming support
- ROHS Compliant

## Application

- LED illumination
- General illumination

## Pin Define

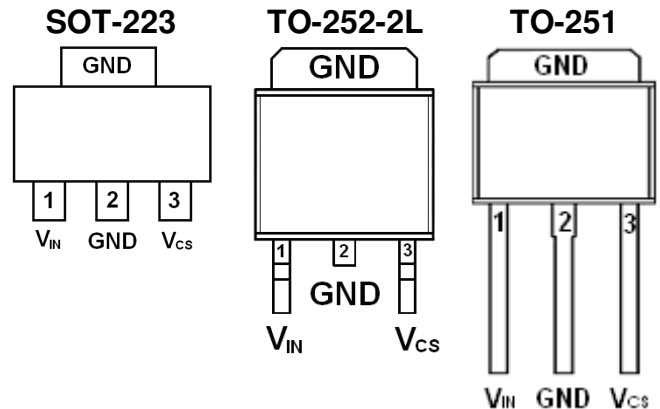

## Marking Information

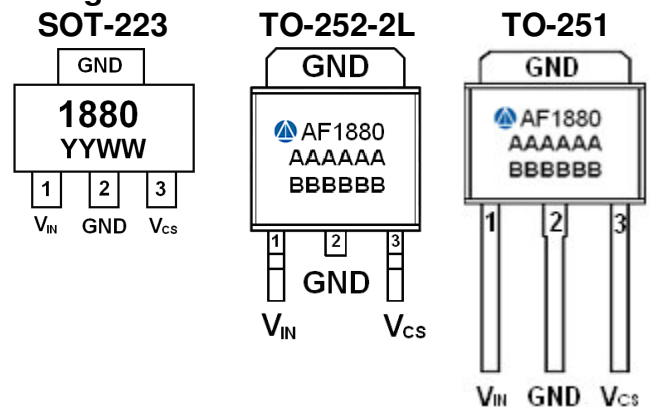



**Typical Application Circuit**

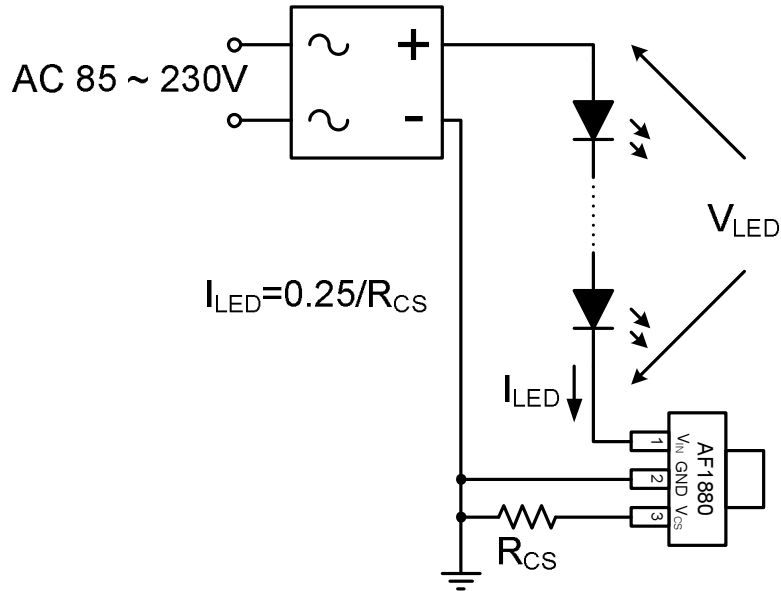

**Pin Description**

Pin	Symbol	Description
V <sub>IN</sub>	1	Power Input. Supply voltage can range from 6 to 500V.
GND	2	Ground
V <sub>CS</sub>	3	Current sense, current setting by place a resistor connect to GND

**Ordering Information**

Part Ordering No.	Part Marking	Package	Unit	Quantity
AF1880S223RG	1880	SOT-223	Tape & Reel	2500 EA
AF1880T252RG	AF1880	TO-252-2L	Tape & Reel	2500 EA
AF1880T251TG	AF1880	TO-251	Tube	80 EA

- ※ 1880 parts code
- ※ YY year code ( 00 ~ 99 )
- ※ WW week code ( 00 ~ 52 )
- ※ A Lot code
- ※ B Date code
- ※ AF1880S223RG : Tape Reel ; Pb- Free ; Halogen- Free
- ※ AF1880T252RG : Tape Reel ; Pb- Free ; Halogen- Free
- ※ AF1880T251TG : Tube ; Pb – Free ; Halogen - Free



**Block Diagram**

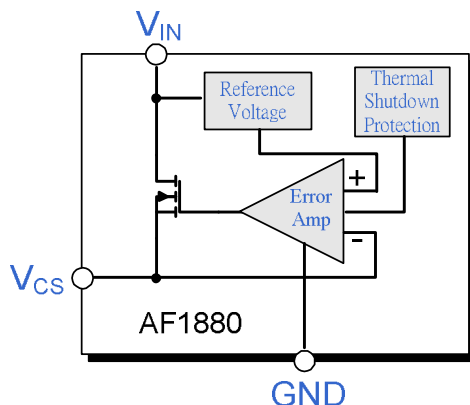

**Absolute Maximum Ratings** ( $T_A=25^{\circ}\text{C}$  Unless otherwise noted)

The following ratings designate persistent limits beyond which damage to the device may occur.

Symbol	Parameter	Value	Unit
$V_{IN}^{(1)}$	$V_{DD}$ Pin Voltage	$V_{SS} - 0.3$ to $V_{SS} + 500$	V
$V_{CS}$	Vout Pin Voltage	$V_{SS} - 0.3$ to 6	V
$P_D$	Power Dissipation	SOT-223	2.8
		TO-252-2L	40
		TO-251	55
$R_{\theta(J-C)}$	Junction to Case Thermal Resistance	SOT-223	15
		TO-252-2L	12
		TO-251	10
$R_{\theta(J-A)}$	Junction to Ambient Thermal Resistance	SOT-223	165
		TO-252-2L	112
		TO-251	100
$T_{OPR}$	Operating Temperature Range	-20 to +85	$^{\circ}\text{C}$
$T_{STG}$	Storage Temperature Range	-40 to +150	$^{\circ}\text{C}$

**Caution:**

The absolute maximum ratings are rated values exceeding which the product could suffer physical damage. These values must therefore not be exceeded under any conditions.

**Electrical Characteristics**

( $T_A=25^{\circ}\text{C}$ ,  $V_{CC}=15\text{V}$ , unless otherwise specified.)

Symbol	Parameter	Conditions	Min.	Typ.	Max.	Unit
$V_{IN}$	Input Voltage		6		500	V
$I_{GND}$	Supply quiescent current	$V_{IN}=100\text{V}$ , $R_{CS}=1\text{M}\Omega$		32	50	$\mu\text{A}$
$V_{CS}$	Current sense voltage	$V_{IN}=6 \sim 500\text{V}$ , $R_{CS}=2.5 \sim 1\text{M}\Omega$	0.225	0.25	0.275	V
$\Delta I_{VR}$	Line Regulation	$V_{IN}=6 \sim 500\text{V}$ , $I_{LOAD}=20\text{mA}$		1	5	%
$\Delta I_{TR}$	Temperature Regulation	Temperature from $-40$ to $85^{\circ}\text{C}$		1	5	%
$T_{SD}$	Thermal shutdown threshold			160		$^{\circ}\text{C}$
$T_{HYS}$	Thermal shutdown hysteresis			25		$^{\circ}\text{C}$



## Function Description

### Current setting

Current setting by place a resistor between  $V_{CS}$  pin and GND, the current as follow:

$$I_{LED} = I_{GND} + \frac{V_{CS}}{R_{CS}} = 32\mu + \frac{0.25}{R_{CS}}$$

### Thermal Considerations

The AF1880 is designed to provide maximum 50mA of continuous current. Maximum power dissipation can be calculated based on the output current and the voltage drop across the part.

The maximum dissipation the package can handle is given by:

$$P_D = \left( \frac{T_{J(MAX)} - T_A}{R_{\theta(JA)}} \right)$$

The actual power dissipation of the circuit can be determined using the equation:

$$P_D = (V_{IN} - V_{LED})(I_{GND} + I_{LED})$$

Substituting  $P_{D(MAX)}$  for  $P_D$  and solving for the operating conditions that are critical to the application will give the maximum operating conditions for the circuit.



**Package Information ( SOT-223 )**

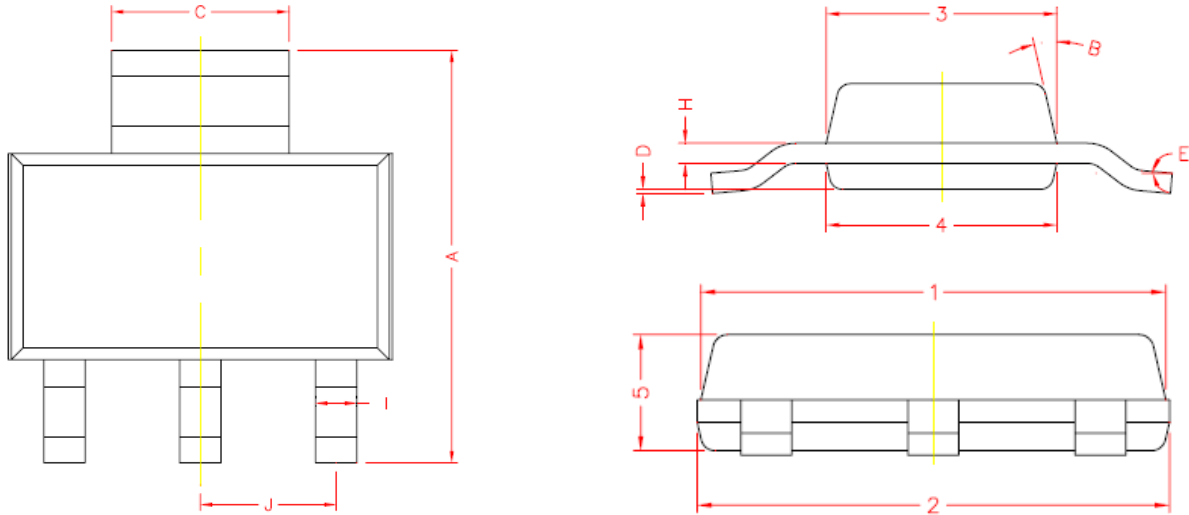

REF.	DIMENSIONS	
	Millimeters	
	Min.	Max.
A	6.70	7.30
C	2.90	3.10
D	0.02	0.10
E	0°	10°
I	0.60	0.80
H	0.25	0.35
B	13° TYP.	
J	2.30 REF.	
1	6.30	6.70
2	6.30	6.70
3	3.30	3.70
4	3.30	3.70
5	1.40	1.80

©2010 Alfa-MOS Technology Corp.  
 2F, No.80, Sec.1, Cheng Kung Rd., Nan Kang Dist., Taipei City 115, Taiwan (R.O.C.)  
 Tel : 886 2) 2651 3928  
 Fax : 886 2) 2786 8483  
 ©http://www.alfa-mos.com



**Package Information ( TO-252-2L )**

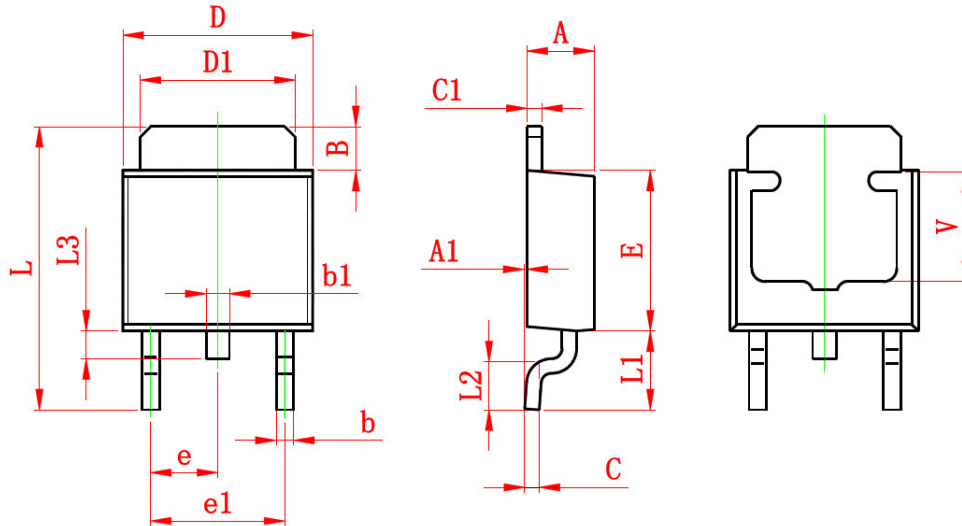

Symbol	Dimensions In Millimeters		Dimensions In Inches	
	Min.	Max.	Min.	Max.
A	2.200	2.400	0.087	0.094
A1	0.000	0.127	0.000	0.005
B	1.350	1.650	0.053	0.065
b	0.500	0.700	0.020	0.028
b1	0.700	0.900	0.028	0.035
c	0.430	0.580	0.017	0.023
c1	0.430	0.580	0.017	0.023
D	6.350	6.650	0.250	0.262
D1	5.200	5.400	0.205	0.213
E	5.400	5.700	0.213	0.224
e	2.300 TYP.		0.091 TYP.	
e1	4.500	4.700	0.177	0.185
L	9.500	9.900	0.374	0.390
L1	2.550	2.900	0.100	0.114
L2	1.400	1.780	0.055	0.070
L3	0.600	0.900	0.024	0.035
V	3.800 REF.		0.150 REF.	

©2010 Alfa-MOS Technology Corp.  
 2F, No.80, Sec.1, Cheng Kung Rd., Nan Kang Dist., Taipei City 115, Taiwan (R.O.C.)  
 Tel : 886 2) 2651 3928  
 Fax : 886 2) 2786 8483  
 ©http://www.alfa-mos.com



**Package Information ( TO-251 )**

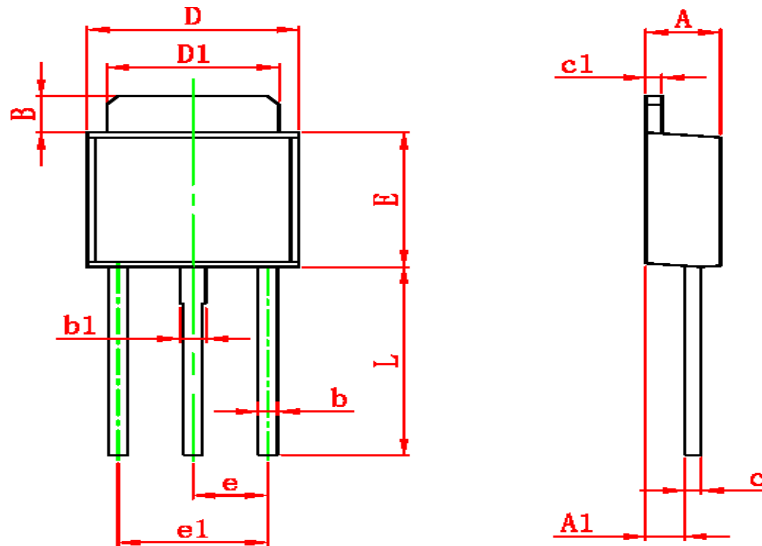

Symbol	Dimensions In Millimeters		Dimensions In Inches	
	Min	Max	Min	Max
A	2.200	2.400	0.087	0.094
A1	1.020	1.270	0.040	0.050
B	1.350	1.650	0.053	0.065
b	0.500	0.700	0.020	0.028
b1	0.700	0.900	0.028	0.035
c	0.430	0.580	0.017	0.023
c1	0.430	0.580	0.017	0.023
D	6.350	6.650	0.250	0.262
D1	5.200	5.400	0.205	0.213
E	5.400	5.700	0.213	0.224
e	2.300 TYP		0.091 TYP	
e1	4.500	4.700	0.177	0.185
L	7.500	7.900	0.295	0.311

©2010 Alfa-MOS Technology Corp.  
 2F, No.80, Sec.1, Cheng Kung Rd., Nan Kang Dist., Taipei City 115, Taiwan (R.O.C.)  
 Tel : 886 2) 2651 3928  
 Fax : 886 2) 2786 8483  
 ©http://www.alfa-mos.com