

Technical Datasheet LS 118

High Power Solid-State LED Light Source

LUSTRON LL608

Introduction

For a brighter solid-state light source, Lustrous Technology is proud to release the new **LUSTRON LL608**. The **LUSTRON LL608** is energy efficient and specifically designed for PAR20, PAR30 or other similar LED lighting applications. **LUSTRON LL608** is also commonly used for other types of Commercial and Architectural applications.

Features

- High efficacy with 120lm/W (3000K CRI80)
- Available in 3-step bins at 3000K, 4000K and 5700K, which ANSI C78.377 compliant
- Available in 80-minimum CRI
- Forward voltage: 35V
- Maximum drive current: 600mA
- 120° viewing angle, uniform chromaticity profile
- RoHS compliant

LUSTRON LL608D

LUSTRON LL608 Part Number Matrix

Table.1

Color		P/N
Warm White	(3000K)	LL608D1202-30B
Neutral White	(4000K)	LL608D1202-40B
Cool White	(5700K)	LL608D1202-57B

LUSTRON LL608 Material

Chip Material	GaN Base
---------------	----------

Mechanical Dimensions

LUSTRON LL608

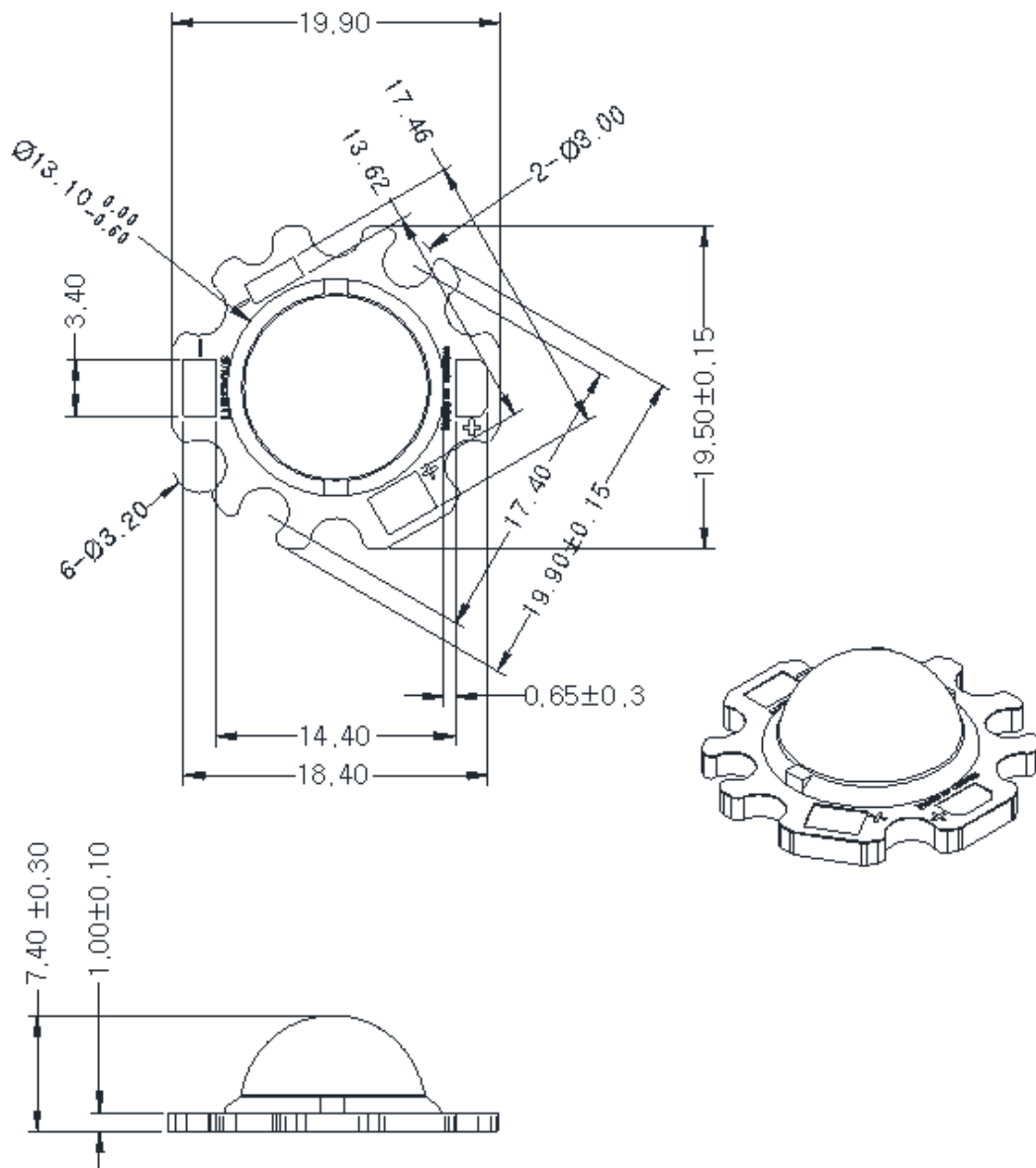

Note1 : These drawings are not for scale. All dimensions are in millimeters.

LUSTRON LL608D

Recommended installation screw pitch

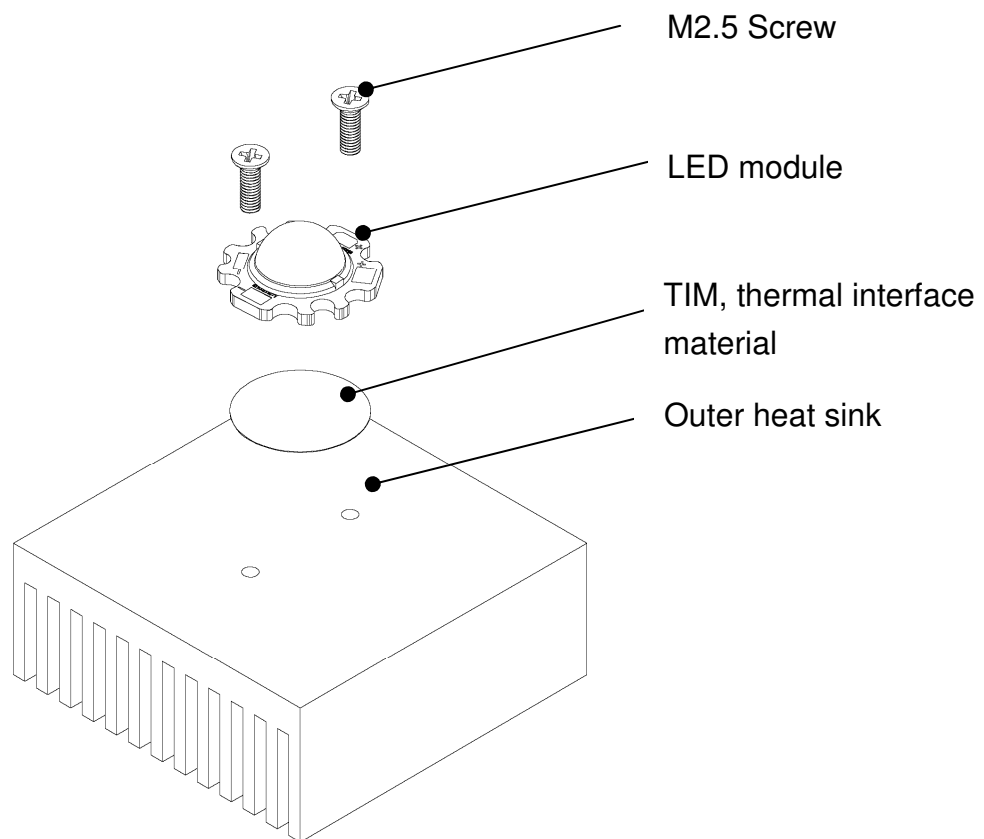

Warning:

Do not touch the lighting surface area during installation.

Flux Characteristics at 240mA, Junction Temperature $T_j = 25^\circ\text{C}$

Table.2

Color	Luminous Flux (lm)		
	Min	Typ.	Typ. ($T_c 85^\circ\text{C}$)
Warm White (3000K)	900	1050	920
Neutral White (4000K)	925	1080	945
Cool White (5700K)	950	1110	970

Note1 : Luminous flux is measured in total power with a tolerance rate of $\pm 10\%$. Minimum luminous flux performance is guaranteed from the above data.

Note2 : Luminous binning information can be found in Table.7.

Note3 : Luminous flux at case temperature of 85°C is for reference.

Optical Characteristics

Table.3

Color	CCT (K)	Viewing Angle (degrees)	CRI
Warm White	3000	~120	> 80
Neutral White	4000		
Cool White	5700		

Note1 : CRI value is measured with a tolerance of ± 3 .

Electrical Characteristics

Table.4

Color	Forward Voltage (V) for 240mA forward current		
	Min	Typ.	Max
Warm White			
Neutral White	33.6	35.0	40.0
Cool White			

Note1 : Lustrous Technology allows a tolerance of each LED for voltage measurements.

Note2 : Measurements are taken under typical forward current.

Absolute Maximum Ratings

Table.5

Parameters	LL608D1202-XXX
Advised DC Forward Current (mA)	240
Max. DC Forward Current (mA)	600
LED Junction Temperature (°C)	< 125
ESD Sensitivity	+4kV (HBM)
Thermal Resistance (°C/W)	~2.2
LED Case Temperature, T _c (°C)	< 85
Storage Temperature (°C)	-20 ~ +50

Note1 : Proper current operating must be observed to maintain junction temperature below the maximum.

Relative Intensity vs. Current (T_j = 25°C)

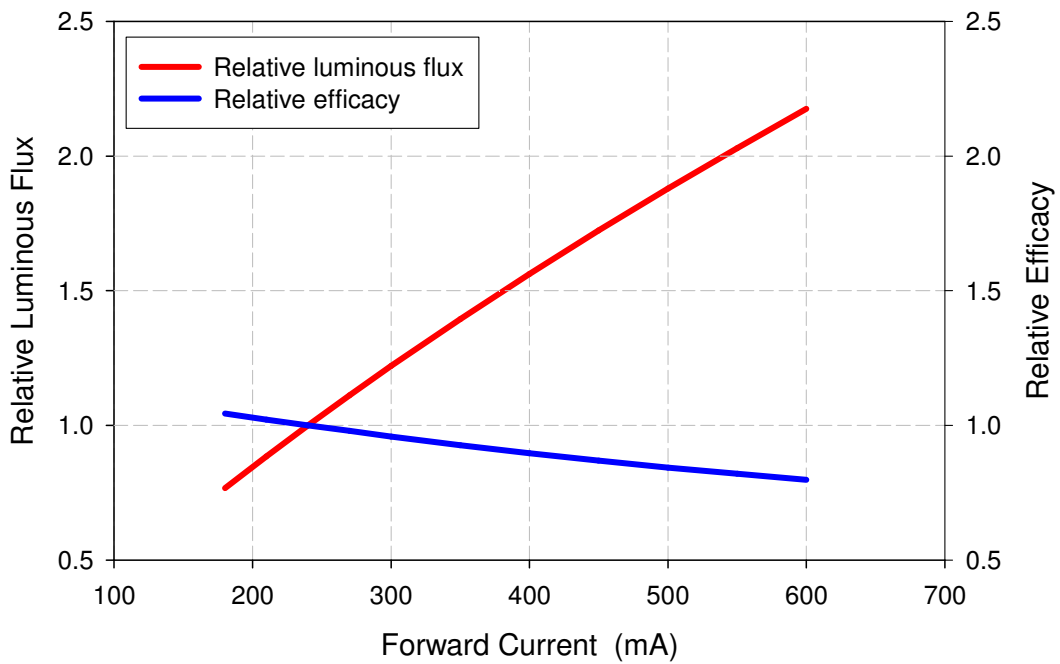

Forward Voltage vs. Current (T_j = 25°C)

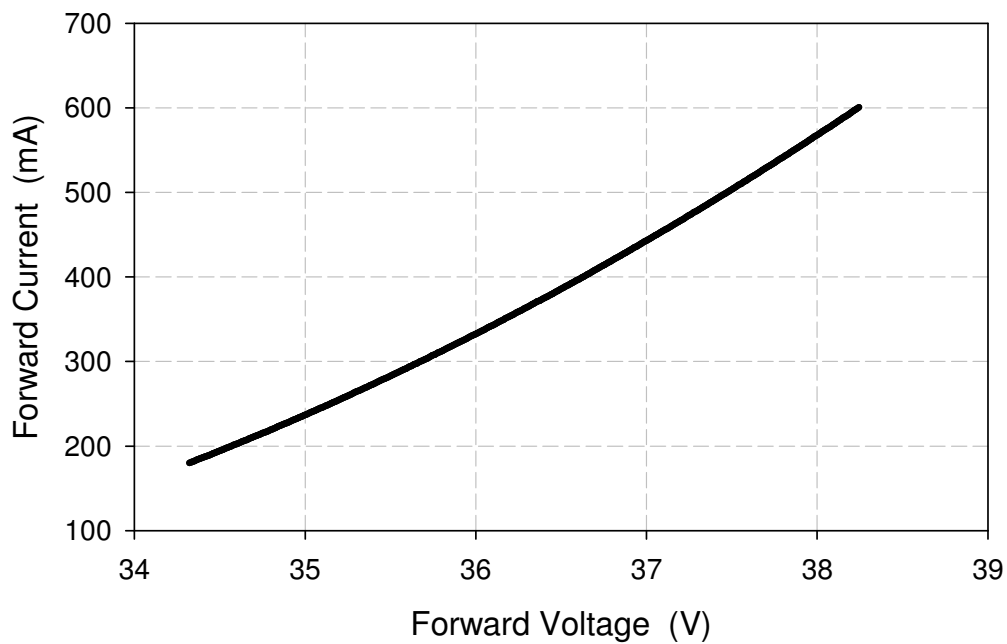

Photometric Output vs. Case Temperature ($I_f = 240\text{mA}$)

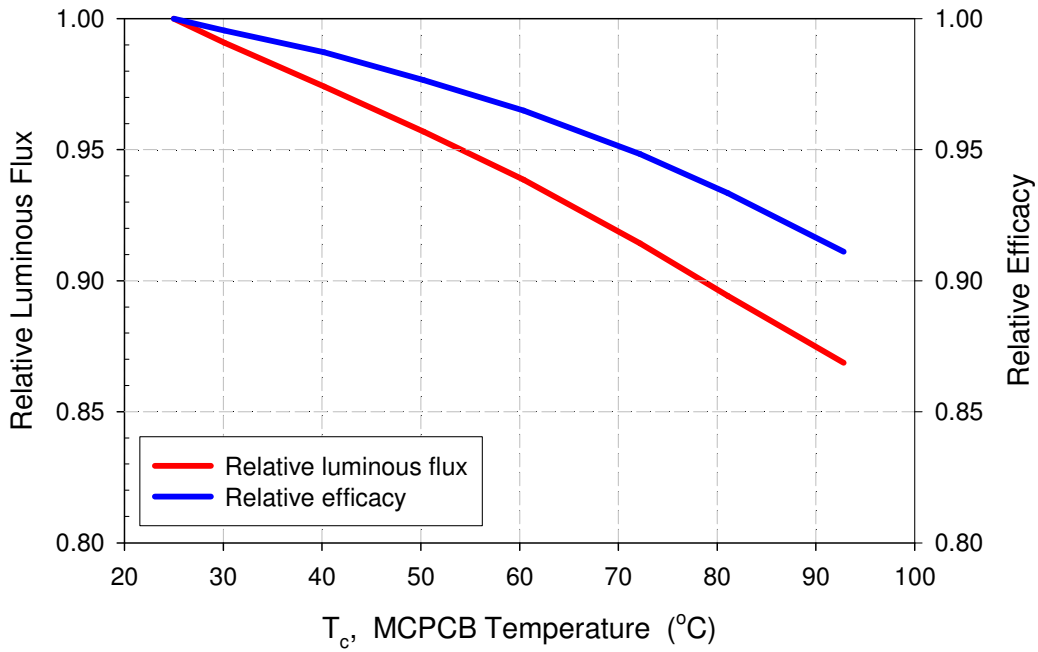

Forward Current vs. Case Temperature ($I_f = 240\text{mA}$)

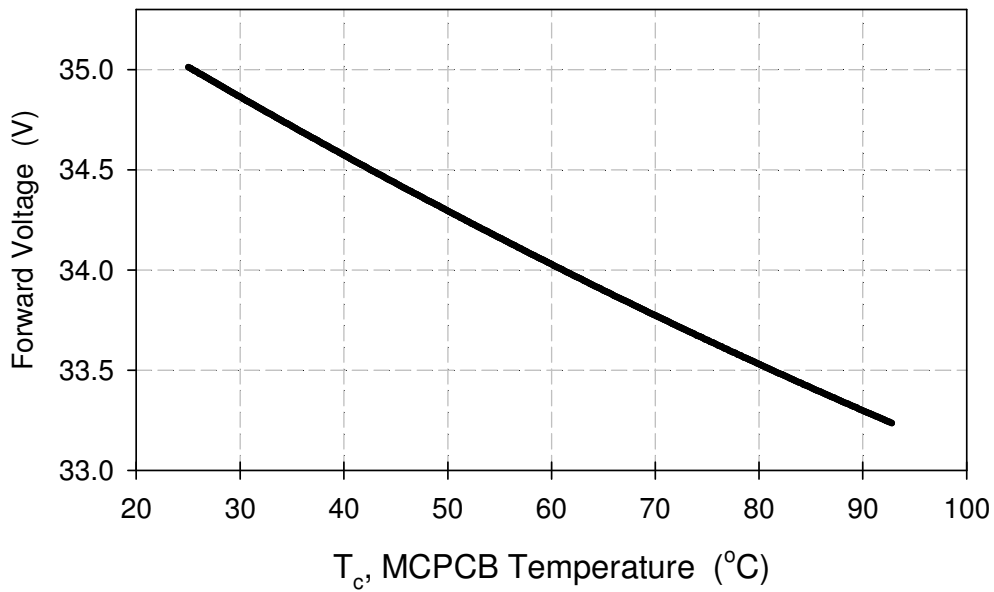

LUSTRON LL608D

Relative Spectral Power

Warm White

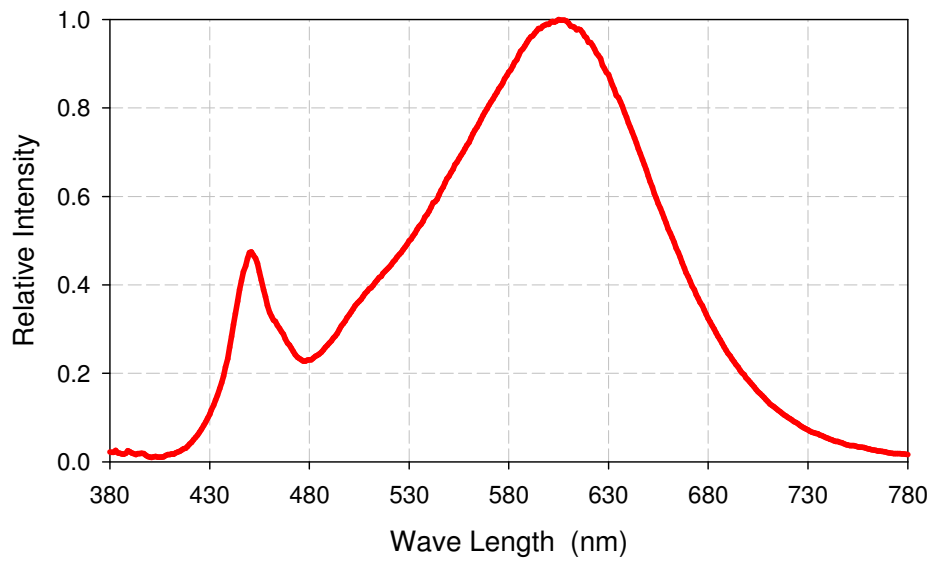

Neutral White

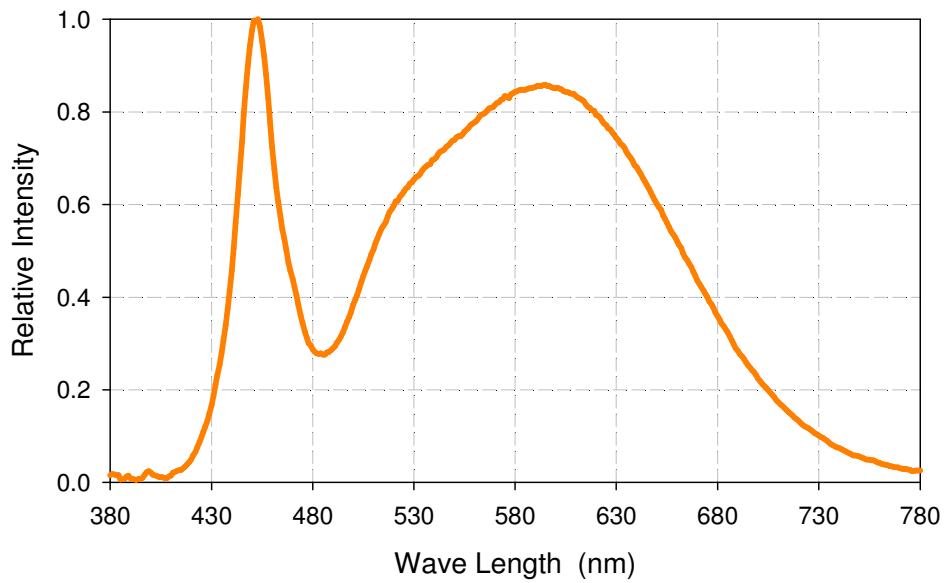

Cool White

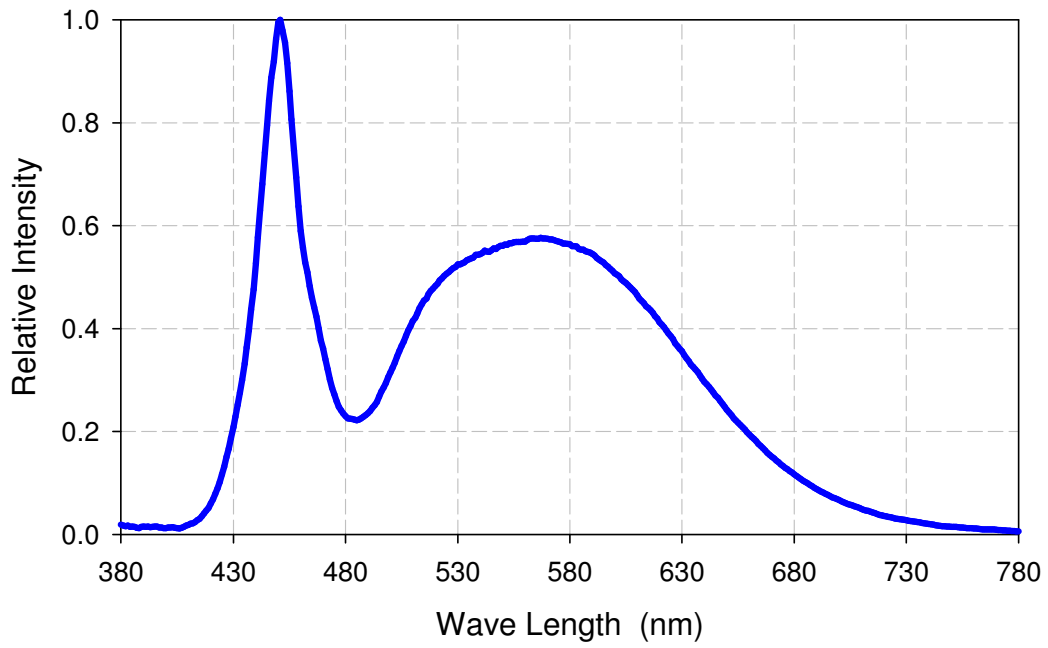

Typical Angular Beam Profile, $T_j = 25\text{ }^\circ\text{C}$

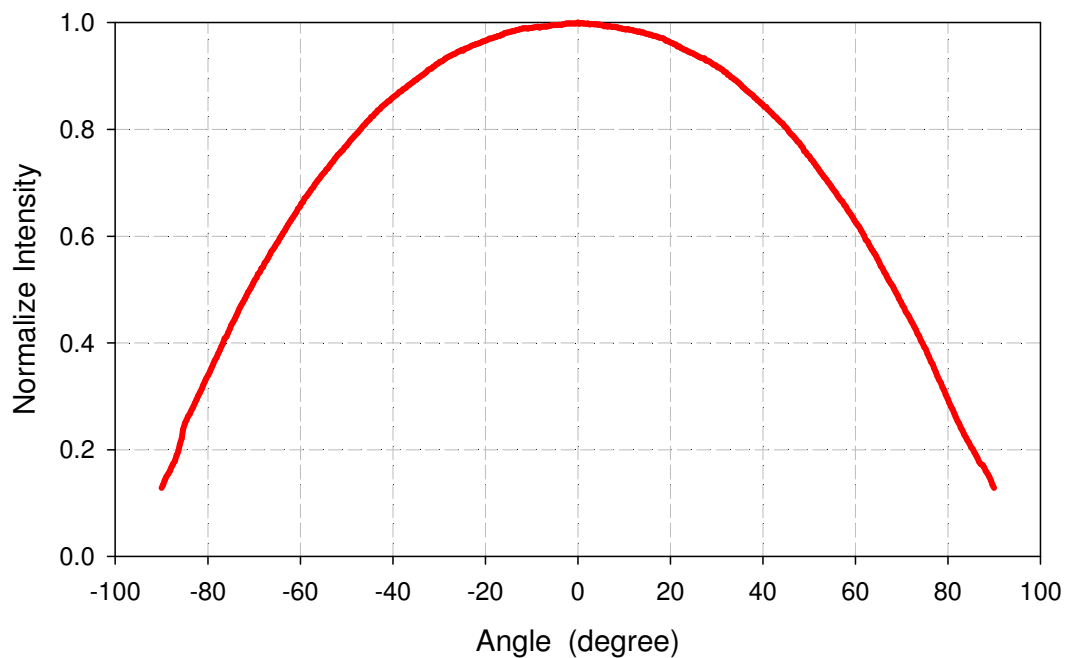
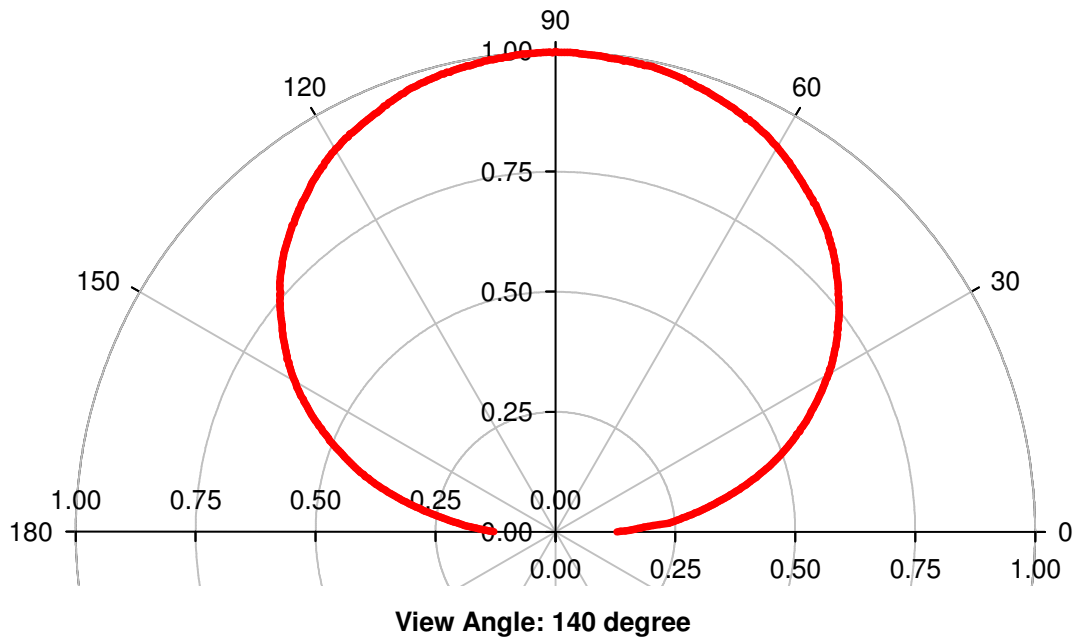

Note1 : Photometrics data is ready on request.

Product Binning

In the manufacturing process, there is a natural variation of specifications between LEDs. In order to minimize variation in the end product of application, Lustrous Technology uses the ANSI C78.377 compliant 3-Step MacAdam Ellipse code binning procedures to measure its products for performance in luminous flux and chromaticity.

The tables below list the standard photometric bins for Lustrous LED products (tested and binned at the indicated test current). **Product availability in a particular bin varies by product and production run. Please contact your Lustrous sales representative for further information regarding product availability.**

Binning Condition

Table.6

Color	Forward Current (mA)
Warm White	240
Neutral White	
Cool White	

Luminous Flux Binning Information

Table.7

BIN Code	Lv (lm)	
	min.	max.
A	5	20
B	20	40
C	40	60
D	60	80
E	80	110
F	110	140
G	140	170
H	170	200
I	200	240
J	240	280
K	280	320
L	320	360
M	360	400
N	400	450
O	450	500

BIN Code	Lv (lm)	
	min.	max.
P	500	580
Q	580	660
R	660	740
S	740	860
T	860	980
U	980	1100
V	1100	1300
W	1300	1600
X	1600	2000
Y	2000	2500
Z	2500	3000
A1	3000	3600
A2	3600	4200
A3	4200	5000
A4	5000	5800

Note1 : Luminous flux is measured in total power with a tolerance rate of $\pm 10\%$.

Chromaticity Binning Information

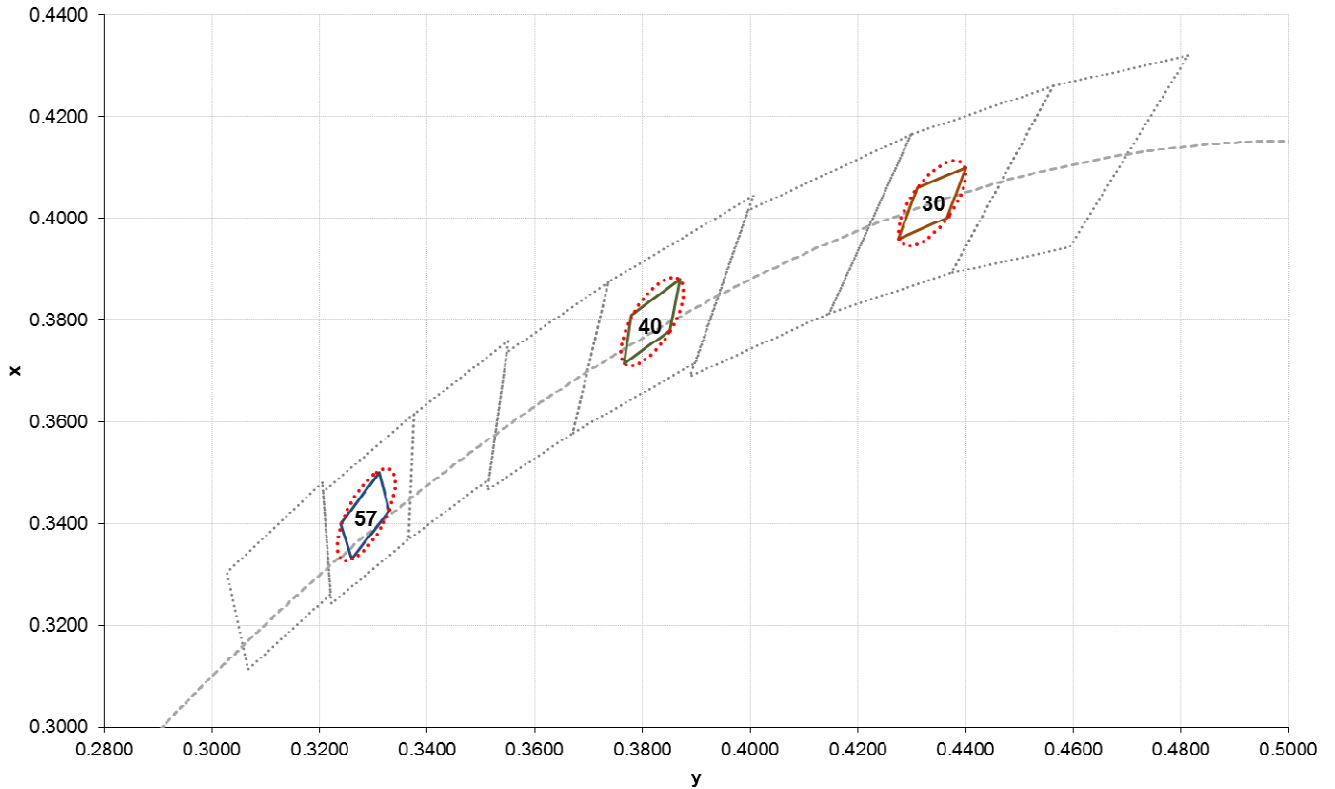

Table.8

BIN CODE	CCT (K)	Chromaticity Coordinate (CIE 1931-xy)								Center	
		x1	y1	x2	y2	x3	y3	x4	y4		
30	3000	0.4400	0.4100	0.4310	0.4060	0.4275	0.3960	0.4365	0.4000	0.4338	0.4030
40	4000	0.3870	0.3880	0.3780	0.3810	0.3765	0.3715	0.3850	0.3780	0.3818	0.3797
57	5700	0.3310	0.3500	0.3240	0.3400	0.3260	0.3330	0.3330	0.3425	0.3287	0.3417

Note1 : Chromaticity is measured in Chromaticity Coordinate (CIE 1931-xy) with tolerance rate of ± 0.005 .

Print Code Guideline

<u>LL6</u>	<u>08</u>	<u>D</u>	<u>1202</u>	-	<u>30</u>	<u>B</u>
1	2	3	4		5	6
<u>XXXXXXXXXXXXXXXXXX</u>						
7						
<u>V0</u>	-	<u>U</u>	-	<u>30</u>	<u>XX</u>	<u>XX</u>
8		9		10	11	12
		13				

Table.9

1 Type	2 Power	3 Lens	4 Internal Code	5 Color	6 CRI
LL6	08 : 8W	D : Dome		30 : 3000K 40 : 4000K 57 : 5700K	B : 80~90

7 Internal Code	8 Bin V _f	9 Luminous Flux	10 Chromaticity
	V0 : Without Binned	See Bin Code Definition	See Bin Code Definition

11 Year	12 Month	13 Week
14 : 2014 15 : 2015	01 : January 05 : May 10 : October	01 : 01 st Week 20 : 20 th Week 45 : 45 th Week

LUSTRON LL608D

Standard Packaging

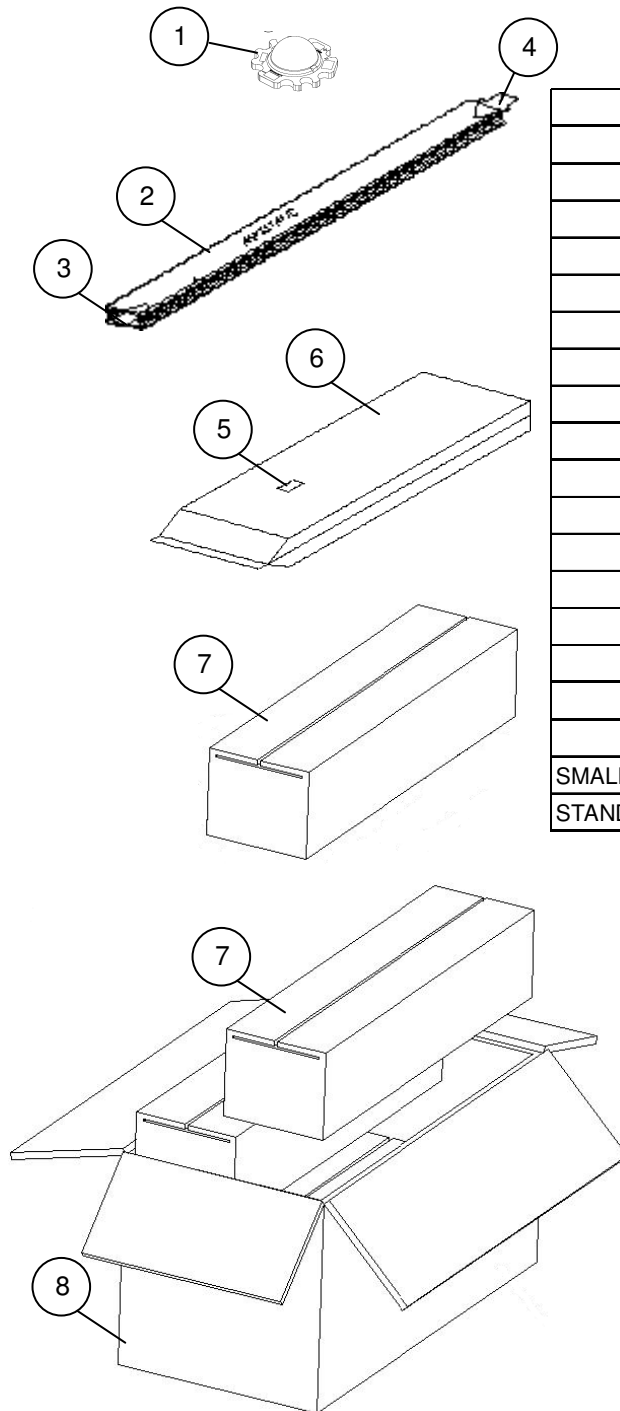

ITEM	DESCRIPTION	
①	LED	
②	PLASTIC TUBE	
③	END-PLUG WHITE	
④	END-PLUG BLACK	
⑤	ADHESIVE MAIN LABEL	
⑥	MOISTURE BARRIER BAG	
⑦	SMALL BOX	
⑧	STANDARD BOX	
STACKING METHOD		
	PCS/TUBE	20
	TUBE/BAG	25
	BAG/SMALL BOX	1
	PCS/SMALL BOX	500
	SMALL BOX/STANDARD BOX	4
	PCS/STANDARD BOX	2000
SIZE AND WEIGHT		
	SIZE(mm ³)	WEIGHT(kg)
SMALL BOX	440×130×130	1.64±0.5
STANDARD BOX	460×280×280	7.25±0.5

Precaution for Use

Installation

1. Do not touch the lighting surface area during installation.
2. If the product might to be used under the following conditions, the customer must evaluate its appropriateness them. This product is not designed for use under the following conditions. In places where the product might:
 - get wet due to rain.
 - suffer from damage caused by salt.
 - be exposed to corrosive gas such as Cl, S, H₂S, NH₃, SO₂, NO_x and so on.
 - be exposed to dust, fluid or oil.

Over-current Proof

1. Do not reverse current the LEDs we suggest current limit resistors for extra protection.
2. The maximum overshoot current should be limited to 600mA.
3. The ripple of driving current should not exceed +/-10% of normal driving current.
4. When driving the products, the clamp voltage must be set at 48V in driver.

Storage

1. Do not open the Moisture Barrier Bag (MBB) before you are ready to install the LEDs.
2. Storage Condition (before opening the MBB) :
 - Storage Temperature: -20~50 °C.
 - Relative Humidity: <60% RH.
 - The products should be used within half a year.
3. Storage Condition (after opening the MBB) :
 - Storage Temperature: -20~50 °C.
 - Relative Humidity: <60% RH.
 - The products should be used or installed as soon as possible after opening the MBB.
 - Please re-seal the MBB when storing longer than 3 weeks.

Company Information

Lustrous Technology, founded in 2004, endeavors to bring a new era of solid-state lighting. Our R&D development center and production facilities are based in Taiwan, a famous island for IT technology in the world. Our products are well designed in both performance and reliability. Lustrous is one of the leading high-power LED manufacturer and solution provider in the world.

**Lustrous Technology may make process and material changes affecting performance and characteristics of our products without further notice. These products supplied after changes will continue to meet published specifications, but may not be identical to products supplied as samples or under prior orders.

LUSTROUS[®]
Green Technology of Lighting

Website : www.lustrous.com.tw

Email : sales@lustrous.com.tw

Tel : +886-2-8647-2862

Fax : +886-2-8647-2863

All rights reserved. Product specifications are subject to change without further notice.

LUSTRON LL608D