

LED New Light Source Reflow Oven

Model: T-960



Taian Puhui Electric Technology Co., Ltd

<http://www.tech168.cn>

Features:

1. This machine selects the intelligent level sirocco and rapid infrared heating technology controlling, equipped with special design wind wheel, speed stability and uniform temperature, suit for uninterrupted soldering the LED and BGA components.
2. This machine is equipped with the crawler-type and five temperature area heating systems, and each temperature area uses independent PID controlling and up-down heating type, can make the inside temperature more accurate and well-proportioned, just take about 20 minutes can let it heat up to the working temperature from the room temperature.
3. Intelligent temperature wave heating type, oversized capacity wave selection, have eight temperature waves can satisfy various welding technological requirements.
4. Use programmable technology, preset the temperature wave memory storage function, can complete the whole welding process automatically according to your presetting wave.
5. Adopt the thermocouple temperature measurement and add the compensation circuit, make the temperature measurement more accurate, the wave more perfect.
6. Use PID intelligent temperature control technology; make the temperature control more accurately. Adopt the imported large current solid-state relay non-contact output can effectively avoid the IC or circuit board damage due to the rapid or uninterrupted warming up, make the whole welding process more scientific safety.

7. Transmission system adopt imported frequency conversion motor, PID closed-loop speed, equip with all the import 1:150 turbine speed reducer, smooth operation, speed adjustable range 0-1600mm/min.
8. Adopt independent wheel structure and special stainless steel strut, durable wear-resisting runs smoothly, speed precision can reach ± 10 mm/min.
9. Independent cooling zone, to ensure the PCB board of low temperature when the required.
10. Friendly human-machine operation interface, perfect LCD display, no need to connect with the PC, can watch the whole repairing process very clearly.
11. Ergonomic design, practical and easily operated. Good build quality but at the same time light weight and a small footprint allows the T-960 to be easily bench positioned, transported or stored.

Technical parameters

Model	T-960
The heating zone quantity	upper3/down2
The length of the heating zone	960mm
The heating type	intelligent level sirocco and rapid infrared heating
The cooling zone quantity	1
Maximum width of PCB board	300MM
The operation direction	left→right
Delivery options	Net transmission+chain transmission
The speed of conveyer belt	0-1600mm/min
The power supply	110V
Peak power	8KW
Heating up time	Around 15mins

Temperature control range	Room temperature~300℃
Temperature control mode	PID closed-loop control
Temperature control accuracy	±1℃
PCB temperature distribution deviation	±2℃
Overall dimensions	1450×630×470
Machine weight	101KGS

Main parts

Complete machine	1
Power line	1
User manual	1

Description of the main parts

1. Welding table main body



2. Control cabinet Panel

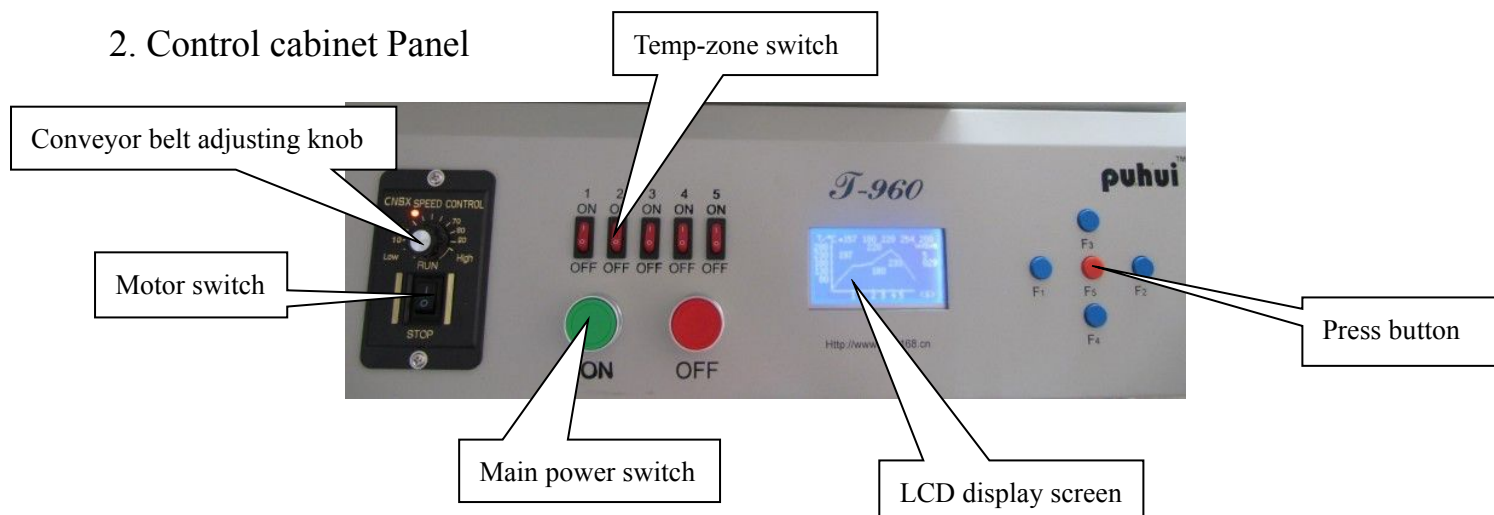

3. The instruction of the connecting line

Separated Connection

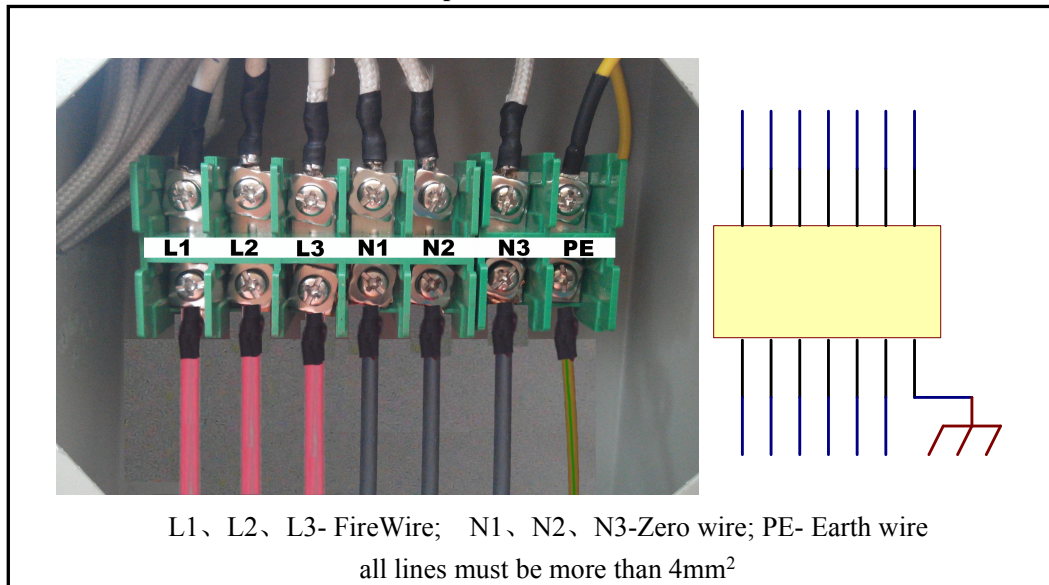

Parallel connection

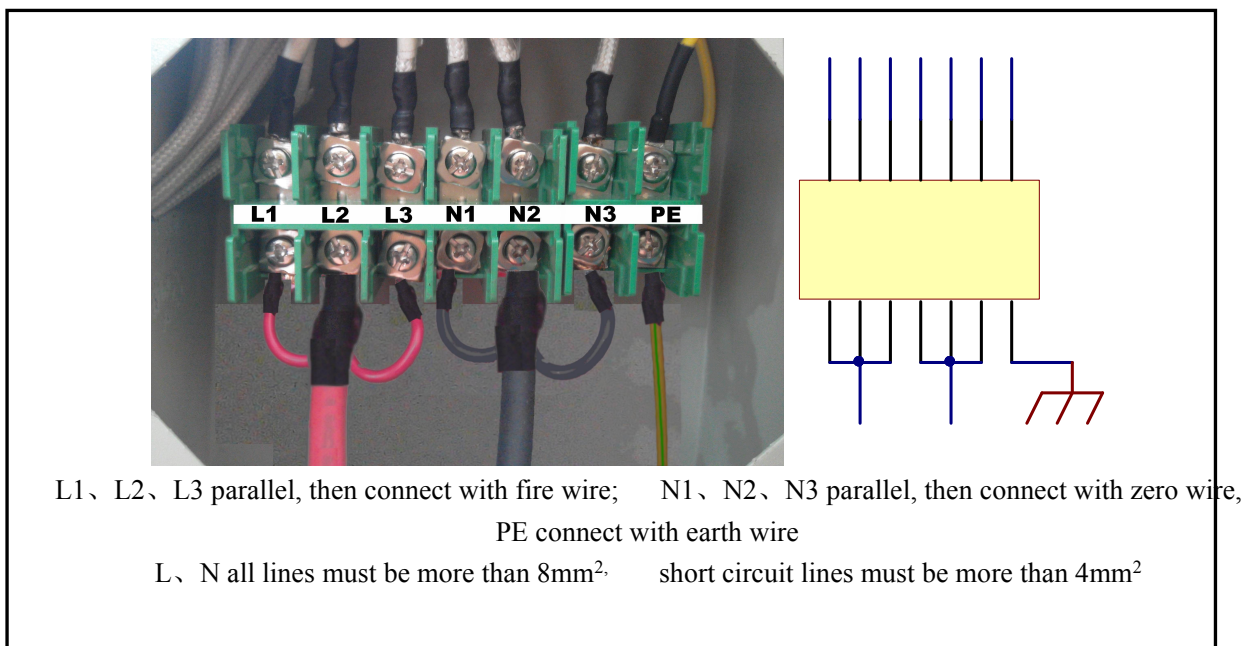

Operating Instructions

1. Enter into the setting interface when starts the machine. Press F2 button to select the wave, press F1 to select the point, press F3/F4 to set the corresponding temperature zone up and down, press F5 goes to the heating interface.

2. Five red switches separately control the upper 1/down 1/upper 2/upper 3/down 2 temperature zones.

3. When the temperature gets to balance, open the Motor switch and adjust the conveyer belt speed.

4. Press F2 stop heating, and enter into the setting interface.

5. Each temperature wave purposes as follows:

Wave one and two: use the same with soldering the less lead paste, like 85Sn/15Pb
70Sn/30Pb

Wave three and four: use the same with soldering the more lead paste, like 63Sn/37Pb
60Sn/40Pb.

Wave five and six: use the same with soldering high-melting-point lead-free paste, like
Sn/Ag3.5; Sn/Cu.75 Sn/Ag4.0/Cu.5 Sn95.5/Ag3.8/Cu0.7

Wave seven and eight: use the same with soldering lead-free solder in melting point,
like Sn/Ag2.5/Cu.8/Sb.5; Sn/Bi3.0/Ag3.0

6. Attentions:

1. According to the chips size and welding technological requirements, select the proper wave.

2. Heating temperature regions distribution of upper three areas, and the lower layer 2 areas, corresponding heating waves of the first section/third section/section 4 of the

first/second section/each.

3. There are lot kinds of solder paste, every company chooses is also not identical. For these reasons, we design this product can set eight waves, each wave has five sections, each section of the heating time and temperature all can alter. You can reset the heating waves according to the solder required heating temperature and time.

4. Please set the speed of conveyor to “0” before turn on, avoid to damage the conveyor speed control unit.

Foundation for wave set

1. The reflow soldering theory and the temperature wave

When the PCB board goes into heat up area (dry area), the solvent and gas in the solder paste will evaporate. At the same time, the flux can wet the pad and the component tip and foot. The solder paste melts, caves in and covers the pad, leading to the pad and component pins insulate the oxygen. PCB board goes into heat preservation area. PCB board and components get full preheating. In case of damaging the PCB and components when it goes into the welding area and the temperature heats up quickly. When PCB board goes into the welding area, the temperature heats up and the solder paste melts. When PCB board goes in to cooling area, the liquid solder paste the soldering points solidify. The reflow process is finished.

The temperature is the key to welding quality. The actual and the setting temperature warming slope and the peak temperature should be accordant. Before the temperature reaches 160°C, please control the heat up speed in about 1°C/S. If heat

up too quickly, the PCB board and the components will be damaged, and the PCB board may be out of shape. On the other side, the flux volatilizes too fast. And it is easy to make soldering tin ball. Set the peak temperature 20°C-40°C higher than the solder paste melting point. Set the reflow time 10S-60S. If the peak temperature is low or the reflow time is short, it will affect the welding quality, and serious is causing the solder paste does not melt. If the peak temperature is high or the reflow time is long, the metal power will be oxidized and affect the welding quality and serious is causing the component and PCB board damaged.

2. The set of the temperature wave

Set the wave according to the solder paste and the above foundation. Different solder paste, choose and set different waves. In addition, the temperature wave has related to the PCB, the density and size of components. Generally lead-free welding temperature should be higher 40°C than melting point.

Temperature Area Set

1. Set the temperature and belt speed to initial value(usually the manufacturer supply when adjust)
2. To the cooling oven, should be preheated for 15-20 minutes.
3. When the temperature is stable, let PCB board pass heat reflow system. Under this set, the solder paste can reach the reflow critical point. If there is no reflow, to operate as step 4. If the reflow is too fast, please keep correct proportion to increase or reduce the temperature. And let the PCB pass the system again until reach the reflow critical point. Then turn to step 4, only when there

is reflow that is good.

4. If there is no reflow, please reduce the belt speed. For example, now the belt speed is 500mm/min, please adjust it to about 460mm/min. Usually, reduce the speed 10% can increase the temperature about 30F. Another way is that, do not adjust the speed, and increase the temperature properly. The increase range standard is the temperature wave. Adjust the temperature on the basis difference between PCB actual and standard temperature. The adjust range is about 5°C. When adjust the temperature, it can not exceed the PCB and component bearing capacity.
5. Let the PCB board pass the reflow system in the new speed or new set temperature. If there is no reflow, back to step 4 to adjust again. Or carry out the step 6 for temperature fine-turning.
6. The heat temperature wave is adjustable according to the PCB board. You can adjust the transmission belt speed to adjust the temperature. Reduce the belt speed can increase the product heat temperature. On the contrary, you can reduce the product heat temperature.
7. Attention: if there is components on the PCB, the PCB pass the reflow and it reflow not very completely, suggest you adjust then reflow again. Usually this cannot damage the components.
8. From low to high when set temperature. If the heat range is over the reflow temperature too high, should increase the transmission speed or reduce the set temperature. The detailed operation is opposite to step 4.

Equipment Installation

1. Set up field.

1.1. Please do the work in the clean environment condition.

1.2. Do not put the machine near the electromagnetism interfering resource.

1.3. Do not put the oven exits and entrances face towards to the fan and the window.

2. Power supply

Please use five-wire system 380V. Ensure the machine contacts the earth well and requested professional electrician operation.

3. Adjust the reflow oven height.

By adjust the machine leg to adjust the height. The way is follow: use industrial or alcohol gradienter to measure. Then adjust the machine leg to adjust the dryer on all sides till it is completely horizontal.

4. Caution:

4.1. The working environment should be clean. So the welder quality is good.

4.2. Do not use and store the machine out of door, high temperature and humid condition.

4.3. During operation take care of the high temperature, avoid scald.

4.4. When overhaul the machine, please cut off the power supply to avoid electric shock or cause short circuit.

4.5. If move the machine after overhaul, must check all the parts, especially the net-belt position. Cannot make it be lock or fall off.

4.6. Ensure the machine is stable, not lean or instable. Adjust the leg under the machine to keep the transmission horizontal. Or the PCB will shift in the transmit

process.

4.7. Do not put too big and big absorbed heat components into the oven avoiding damage the net-net and affect the temperature.

4.8. Put lubricating oil into the transmission chain every 7 days.

4.9. Do not put the inflammable and explosive dangerous goods near the reflow oven.

4.10. Do not reach hands into the reflow oven when the machine is in normal working condition.

Daily Maintenance

1. Keep the electrical control cabinet clean.
2. Check the fan shaft sleeve is in good condition.
3. Check the fan and the electro-motor have abnormal sound.
4. Be sure the fan does work flexibly.
5. Check the air hole if there are abnormal materials.
6. Check the transmission net-belt is in good condition.
7. Check the electrical chest and electrical equipment have abnormal sound.
8. Check the transmission part if it is in good condition and has abnormal sound.
9. Before turn on the machine, please check the working voltage if it is in the safe voltage and if it is stable. Ensure all the parts can work safely and normally. At the same time, when turn on the machine, check the parameters are the same to the last time turn off. When turn off the machine, do not let the transmission belt in the hot area, please turn off the temperature and when cool down well and stop the

transmission belt.

10. Lubricate the driving rolls. Put lubricating oil every two months.

11. The motor works in high temperature for long time, please put lubricating oil twice a week or more, ensure the motor can work normally.

12. Clean the residual goods on the fan blade and motor timely. Or the circuit ages will lead to short circuit and damage the fan.

13. Be sure the machine contacts the earth when use five-wire system.

Statement: These images and screenshots in this product manual may very slightly different from the actual purchased product.