



---

# BK3221 Bluetooth Speaker Datasheet

---

## *Objective Specification*

### Approvals

<b>Name</b>	<b>Date</b>	<b>Signature</b>

Beken Corporation  
3A, 1278 Keyuan Rd, Shanghai 201204, China  
PHONE: (86)21 5108 6811  
FAX: (86)21 6087 1277

*This document contains information that may be proprietary to, and/or secrets of, Beken Corporation. The contents of this document should not be disclosed outside the companies without specific written permission.*

*Disclaimer: Descriptions of specific implementations are for illustrative purpose only, actual hardware implementation may differ.*



---

---

## ***Revision History***

<b>Rev.</b>	<b>Date</b>	<b>Author(s)</b>	<b>Remark</b>
0.1	27/Dec/2011	Weifeng	Initial Draft



**Contents**

- 1. General Description ..... 6
  - 1.1. Features ..... 6
  - 1.2. Applications ..... 6
- 2. Pin Definition..... 7
- 3. Functional Description..... 9
  - 3.1. I2C Interface ..... 9
  - 3.2. UART Interface..... 9
  - 3.3. GPIO ..... 9
  - 3.4. Audio DAC ..... 9
- 4. Electrical Characteristics ..... 9
  - 4.1. Absolute Maximum Ratings ..... 9
  - 4.2. Recommended Operating Conditions ..... 10
  - 4.3. Typical Power Consumption..... 10
  - 4.4. RF Characteristics ..... 10
  - 4.5. Audio Characteristics ..... 10
- 5. Application Schematic ..... 10
- 6. Package Information ..... 11
- 7. Solder Reflow Profile ..... 12
  - 7.1. RoHS Compliant ..... 12
  - 7.2. ESD Sensitivity ..... 12
- 8. Ordering Information..... 13



---

---

**List of Tables**

TABLE 1 PIN DEFINITION.....	7
TABLE 2 QFN5*5 32 PIN PACKAGE DIMENSIONS.....	11
TABLE 3 SOLDER REFLOW PROFILE .....	12



**List of Figures**

**FIGURE 1 BK3221 PIN DEFINITION DIAGRAM ..... 7**  
**FIGURE 2 BK3221 APPLICATION DIAGRAM ..... 10**  
**FIGURE 3 CLASSIFICATION REFLOW PROFILE..... 12**

## 1. General Description

The BK3221 chip is a highly integrated single-chip Bluetooth speaker device. It integrates the high-performance transceiver, rich features baseband processor, and Bluetooth audio profile.

- -88 dBm sensitivity for 1 Mbps mode and 2 dBm transmit power
- A2DP v1.2, AVRCP v1.0
- Integrated 70 dB SNR stereo DAC
- Ten GPIOs for audio remote control and LED indicator
- 26 MHz crystal reference clock
- 32-pin QFN 5mmx5mm package

### 1.1. Features

- Operation voltage from 2.8 V to 3.6 V
- Bluetooth 2.1 + EDR compliant

### 1.2. Applications

- Bluetooth stereo speaker

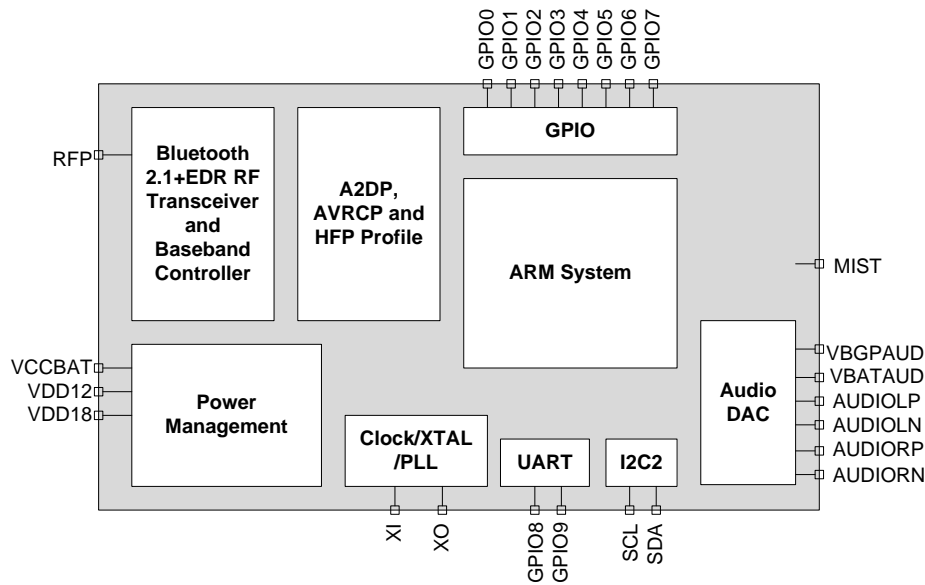

## 2. Pin Definition

It provides QFN5x5 32-pins package for application.

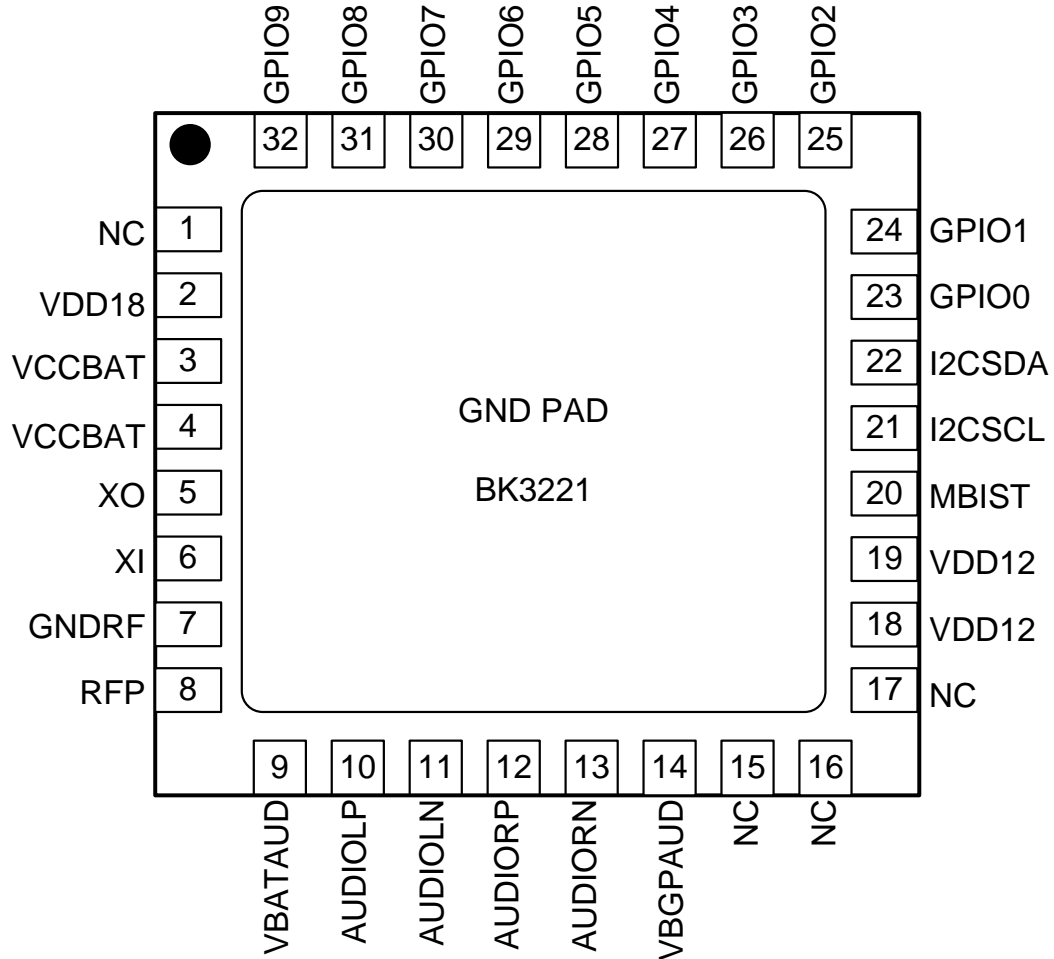

Figure 1 BK3221 PIN Definition Diagram

Table 1 Pin Definition

Package Pin #	Name	Description
1	NC	Reserved
2	VDD18	1.8V LDO output, connected with 4.7 uF decoupling cap
3	VCCBAT	Whole chip power supply
4	VCCBAT	Whole chip power supply



5	XO	Crystal output.
6	XI	Crystal input or oscillator input.
7	GNDRF	Ground for RF
8	RFP	RF input and output
9	VBATAUD	Audio block power supply
10	AUDIOLP	Left channel audio output positive
11	AUDIOLN	Left channel Audio output negative
12	AUDIORP	Right channel audio output positive
13	AUDIORN	Right channel Audio output negative
14	VBGPAUD	Audio band gap LDO
15	NC	
16	NC	
17	NC	
18	VDD12	1.2 V regulator output, connected with 4.7 uF decoupling cap
19	VDD12	1.2 V regulator output, connected with 4.7 uF decoupling cap
20	MBIST	Test pin; Must be pulled low for normal work
21	I2CSCL	I2C clock
22	I2CSDA	I2C data
23	GPIO0	GPIO 0
24	GPIO1	GPIO 1
25	GPIO2	GPIO 2
26	GPIO3	GPIO 3
27	GPIO4	GPIO 4
28	GPIO5	GPIO 5
29	GPIO6	GPIO 6
30	GPIO7	GPIO 7
31	GPIO8	GPIO 8, or UART TX
32	GPIO9	GPIO 9, or UART RX



### 3. Functional Description

#### 3.1. I2C Interface

There is one set of I2C interface for external EEPROM access.

#### 3.2. UART Interface

The UART interface is to allow external MCU send AT command to the BK3251. Its two pins can be also used as GPIO.

#### 3.3. GPIO

There are ten GPIOs, which can be programmed to be either input or output, either pull up or pull down.

GPIO0 and GPIO1 can be used as external interrupt source with either level trigger or edge trigger.

GPIO2 and GPIO3 can be used for LED indicator with PWM controller.

GPIO4 to GPIO7 can be used as four-wires SPI interface either master mode or slave mode.

#### 3.4. Audio DAC

There is a DAC have two channels for stereo application. It supports both 44.1 kHz and 48 kHz sample rate, with up to 70 dB SNR.

### 4. Electrical Characteristics

#### 4.1. Absolute Maximum Ratings

Parameter	Description	MIN	TYP	MAX	Unit
VCCBAT	Battery regulator Supply voltage	-0.3	3.3	4.2	V
P <sub>RX</sub>	RX input power	-	10	-	dBm
T <sub>STR</sub>	Storage temperature range	-40	-	150	°C
VCCIO	IO interface voltage	-0.3	2.8	3.6	V

#### 4.2. Recommended Operating Conditions

Parameter	Description	MIN	TYP	MAX	Unit
VCCBAT	Battery regulator Supply voltage	2.8	3.3	3.6	V
T <sub>OPR</sub>	Operation temperature range	-20	-	80	°C
VCCIO	IO interface voltage	1.8	-	3.6	V

#### 4.3. Typical Power Consumption

State	Description	MIN	TYP	MAX	Unit
Shut down			500		uA
Idle			2		mA
Active (Playing Music)			40		mA

#### 4.4. RF Characteristics

Parameter	Condition	MIN	TYP	MAX	Unit
Operate Frequency	2402~2480	2402		2480	MHz
RXSENS-1 Mbps	BER=0.001		-88		dBm
RXSENS-2 Mbps	BER=0.0001		-90		dBm
RXSENS-3 Mbps	BER=0.0001		-82		dBm
Maximum received signal	BER=0.001	0			dBm
Maximum RF transmit power		9			dBm
RF Power Control Range		30			dB

#### 4.5. Audio Characteristics

Parameter	Condition	MIN	TYP	MAX	Unit
DAC Output Amplitude			100		mVrms
DAC output SINAD	1 kHz sine wave		70		dB
Sample Rate		8		48	kHz

### 5. Application Schematic

TBD.

Figure 2 BK3221 Application Diagram

## 6. Package Information

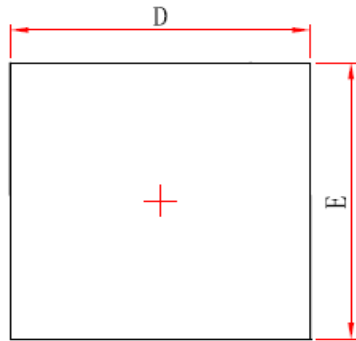

**Top View**

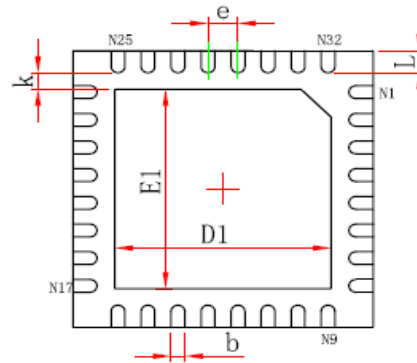

**Bottom View**

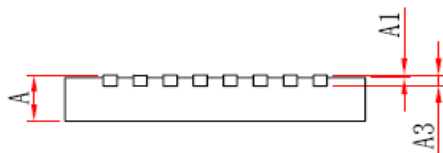

**Side View**

**Table 2 QFN5\*5 32 Pin Package Dimensions**

Symbol	Dimensions In Millimeters		Dimensions In Inches	
	Min.	Max.	Min.	Max.
A	0.700/0.800	0.800/0.900	0.028/0.031	0.031/0.035
A1	0.000	0.050	0.000	0.002
A3	0.203REF.		0.008REF.	
D	4.924	5.076	0.194	0.200
E	4.924	5.076	0.194	0.200
D1	3.300	3.500	0.130	0.138
E1	3.300	3.500	0.130	0.138
k	0.200MIN.		0.008MIN.	
b	0.180	0.300	0.007	0.012
e	0.500TYP.		0.020TYP.	
L	0.324	0.476	0.013	0.019

## 7. Solder Reflow Profile

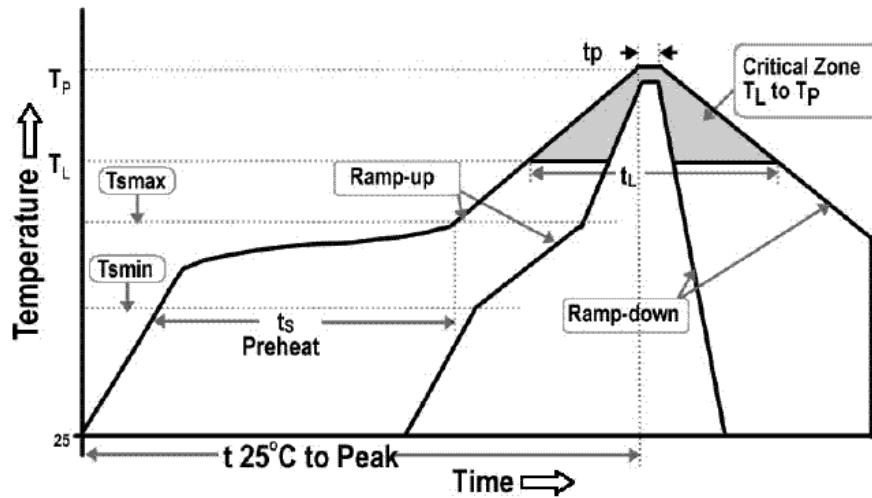

Figure 3 Classification Reflow Profile

Table 3 Solder Reflow Profile

Profile Feature		Specification
Average Ramp-Up Rate (tsmax to tp)		3°C/second max.
Pre_heat	Temperature Min (T <sub>min</sub> )	150°C
	Temperature Max (T <sub>max</sub> )	200°C
	Time (ts)	60-180 seconds
Time Maintained above	Temperature (T <sub>L</sub> )	217°C
	Time (t <sub>L</sub> )	60-150 seconds
Peak/Classification Temperature (T <sub>p</sub> )		260°C
Time within 5°C of Actual Peak Temperature (tp)		20-40 seconds
Ramp-Down Rate 6		6°C/second max.
Time 25°C to Peak Temperature 8		8 minutes max.

### 7.1. RoHS Compliant

The product does not contain lead, mercury, cadmium, hexavalent chromium, PBB&PBDE content in accordance with directive 2002/95/EC(RoHS).

### 7.2. ESD Sensitivity

Integrated circuits are ESD sensitive and can be damaged by static electricity. Proper ESD techniques should be used when handling these devices.



**8. Ordering Information**

<b>Part number</b>	<b>Package</b>	<b>Packing</b>	<b>MOQ (ea)</b>
BK3221QB	QFN	Tape Reel	3 k
BK3221QC	QFN	Tray	10 k

**Remark:**

**MOQ: Minimum Order Quantity**