

BIDIRECTIONAL SERVO-AMP AND PULSE WIDTH DETECTOR

features

- Bidirectional operation with single supply
- 400mA load current capability without external power transistors
- Easily Time division multiplexed for multi-channel operation
- Adjustable dead-band

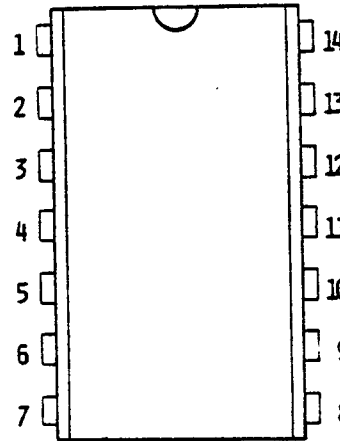

AUGUST, 1980

description

The SN76604N is a pulse width demodulator and servo-amplifier with internal output transistors designed for remote control applications. It contains an internally generated reference pulse whose width is compared to the bidirectional amplifier which drives an external servomotor until the error pulse is within some minimum "dead-band" of zero. Dead-band width is controlled by the external capacitor on pin 9.

The SN28604N is an electrically identical part to the SN76604N and is available in a 12-pin package.

applications

Consumer applications include the following:

- Toys: Car, tank, robot, model aircraft
- Home Entertainment: Stereo, games, intercoms
- Industry: Camera control, emergency signal, flow control

TEXAS INSTRUMENTS
INCORPORATED

POST OFFICE BOX 225012 • DALLAS, TEXAS 75265

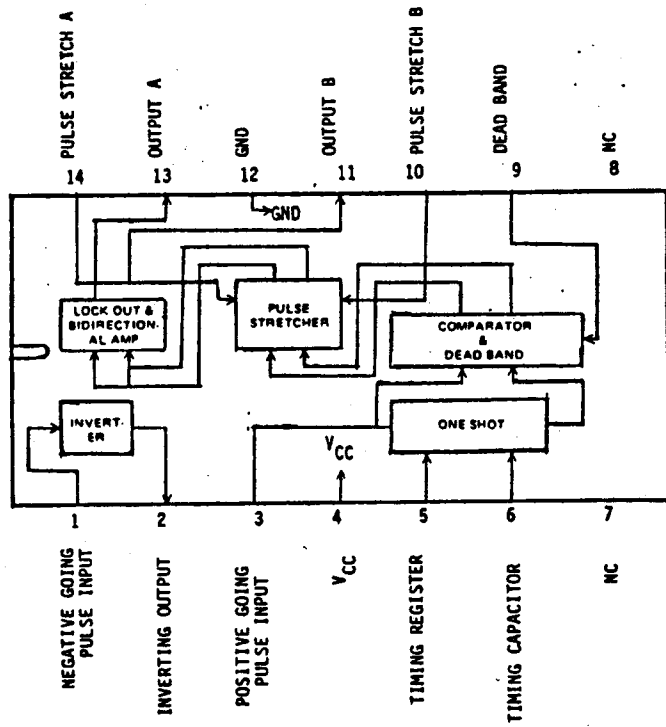

SN76604N BLOCK DIAGRAM

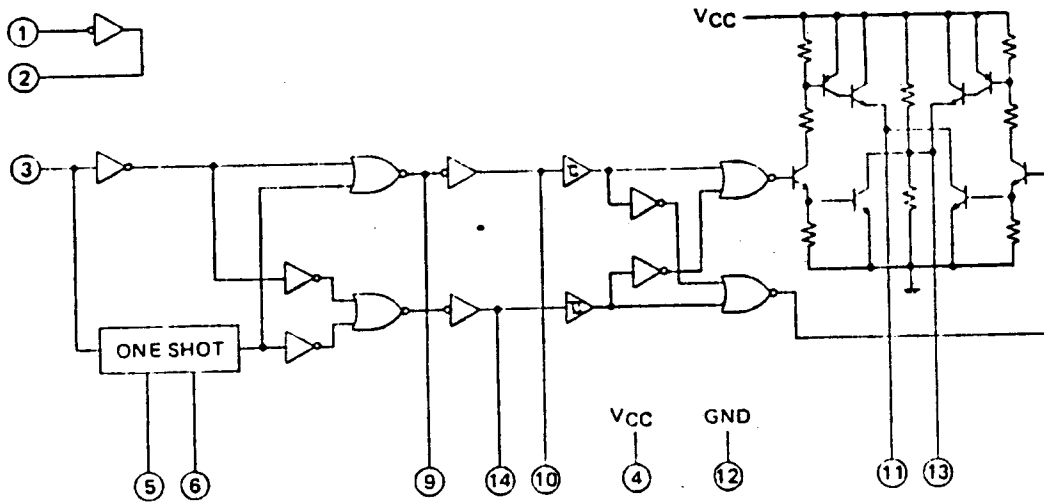

SN76604N LOGIC DIAGRAM

ADVANCED CIRCUITS

SN76604N

electrical characteristics at 25°C, $V_{CC} = 4.8V$

PARAMETER	TEST CONDITIONS	MIN	TYP	MAX	UNIT
Supply Current	Pin 3, 6 = GND	-	12	15	mA
	pin 3 = V_{CC} , pin 6 = GND	-	40	45	mA
Input Current	pin 1 or pin 3 = 1.5 volts	-	0.17	0.3	mA
Output Voltage	output offset voltage with no input (pin 11 & 13)	-	0.001	0.5	volts
	differential output voltage into 10 load (pin 11 & 13) "full on"	2.8	3.5	-	volts
	voltage pin 11 to GND with no input, no load	1.9	2.45	2.9	volts
Internal Deadband Timing Resistor	pin 9 = GND	7.5	10	12.5	K

DC TEST COFIGURATION

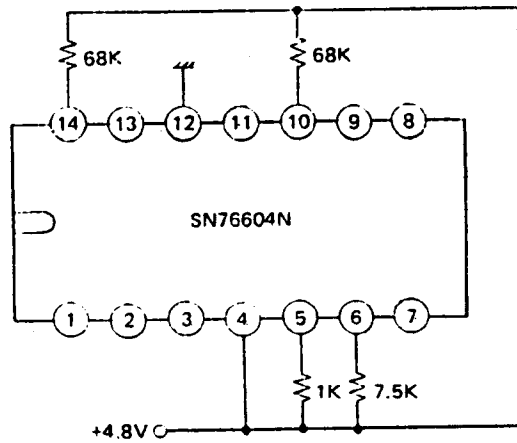

description

a. Input Circuit

Because of an integrated inverter the SN76604N can be driven from negative or positive going pulses. Positive going pulses are fed directly into pin 3. Negative going pulses are fed into the inverter at pin 1 and pin 2 and 3 have to be tied together. The trigger level for the pulses is 1 volt.

Negative voltage pulses have to be coupled capacitively as shown in fig. 2. The pulse amplitude then has to be 4-5 volts peak-peak with 4.8V supply.

b. Reference Pulse Circuit

The external set up for the reference pulse circuit is shown in fig. 3.

The reference pulse width of the monostable is given by the equation:

$$T_{on} = 0.9 \cdot R_1 \cdot C_1 \cdot (V_p - 0.7) / V_{CC}$$

Where V_p is the voltage at the wiper of the servo potentiometer. For correct function following limits should be observed.

- 1) $3K < R_1 \leq 12K$
- 2) $V_p \text{ min} = 1V$
- 3) $R_2 \text{ min} = 1.5K$

R_4 can be omitted if it is ensured that the wiper voltage never decreases below 1 volt, e.g., if the motor shaft rotation is maximum 180° and a 270° potentiometer is used.

The minimum time period from one input pulse to the next one is defined by the RC time constant of the charging circuit, which is highest with the wiper in mid position. For high duty cycles therefore, a low impedance potentiometer shall be used.

The minimum period between input pulses is

$$T_{off} = 10 \times R_0 \cdot C_1$$

R_0 is the equivalent charging resistance, defined by R_2 , R_3 , R_4 and

$$R_{BE}(Q_{31}).$$

Choosing R_1 maximum (12K) and R_2 minimum (1.5) 100% duty cycle is possible.

Variations of reference pulse width with respect to supply voltage changes are eliminated and

$$\frac{T/T}{V_{CC}/V_{CC}} < 0.2$$

description (cont'd)

The temperature coefficient of the reference pulse width is given by the TC of R_1 , C_1 .

In order to avoid jitter of the reference pulse the outputs (pin 11-13) must be loaded with at least 1K.

c. Dead Band

The purpose of the dead band is to avoid motor-boating. The dead band is made by shortening the difference pulse (error signal) if the reference pulse is shorter than the input pulse. This results in a small time hysteresis. The dead band is defined by the capacitor from pin 7 to ground and typical correlation values are

$$T_{\text{dead band}} = 3 \text{ us/nF}$$

d. Pulse Stretcher Circuit

The difference pulses might be too short for starting the motor. For this reason the difference pulses can be widened up to nearly 100% output duty cycle.

If R_6 is greater than 30K the minimum output pulse width is defined by $R_6 C_4$ and the hysteresis of the Schmitt-Trigger (0.7V) and then the ratio of maximum output pulse width is a factor of three.

If R_6 is less than 10K the Schmitt-Trigger action is disabled and the minimum output pulse width can be zero. The slope of error pulse width correlation can be adjusted by R_7 .

e. Lock Out Circuit

If the output bridge would become conducting in both directions by any circumstances a lock out logic then avoids excessive currents by pulling the output down to zero.

f. Power Output Stage

For forward-backward operation of the motor with only one untapped supply voltage, pin 13 is connected to an internal voltage divider. Because therefore, one motor terminal (pin 13) is always at a constant voltage level. A revolution rate dependent feedback can be taken from the other motor terminal by a resistor (typical 10-30K) connected from pin 11 to pin 5.

Fig. 2 Input set up

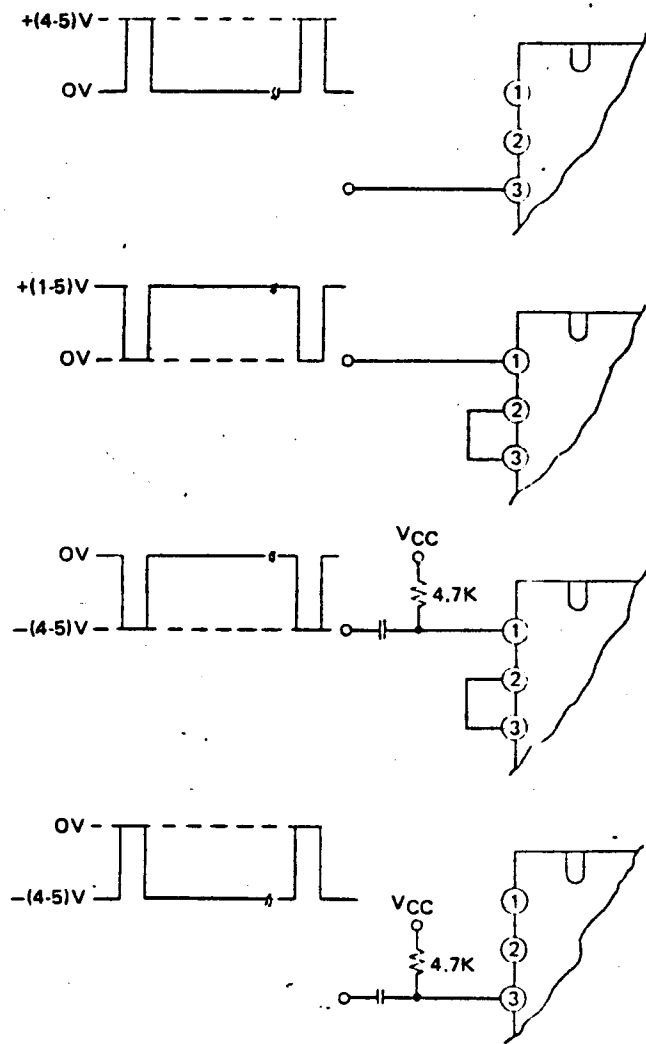
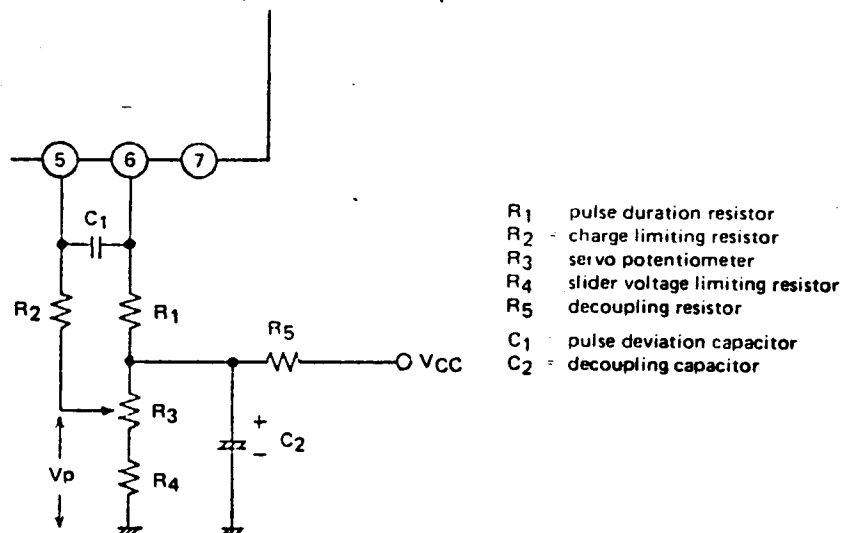
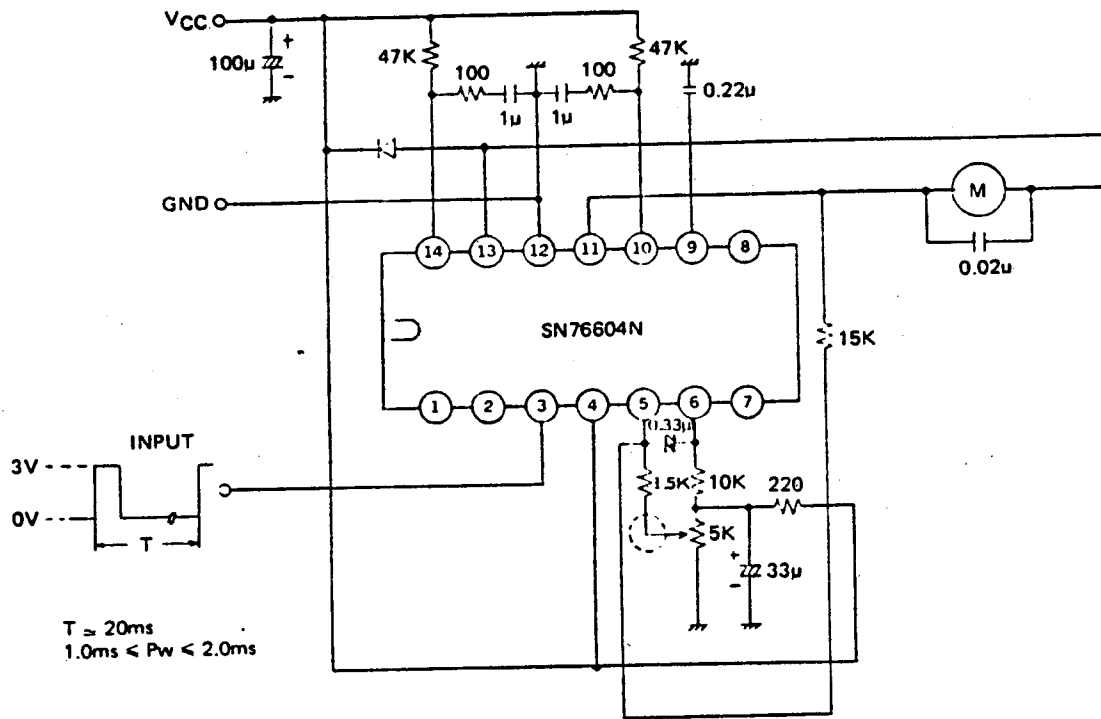

Fig. 3 Monostable set up



- R1 pulse duration resistor
- R2 charge limiting resistor
- R3 servo potentiometer
- R4 slider voltage limiting resistor
- R5 decoupling resistor
- C1 pulse deviation capacitor
- C2 decoupling capacitor



APPLICATION CKT EXAMPLE

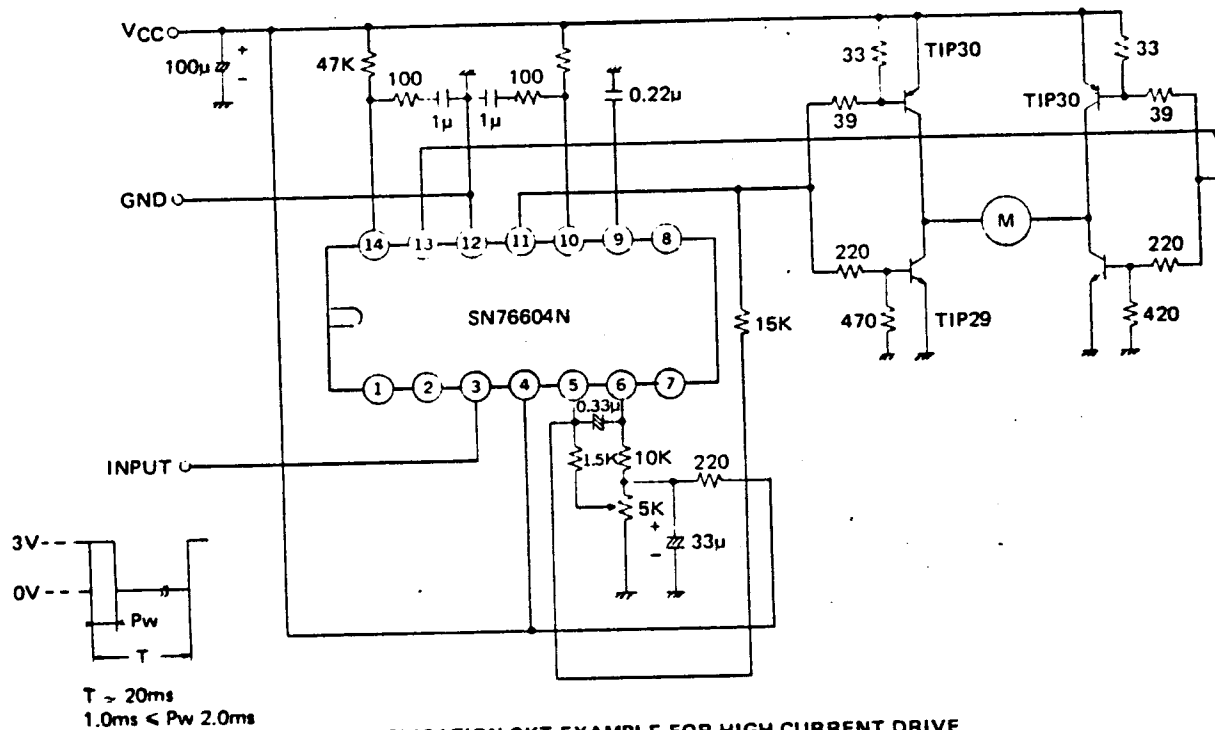

APPLICATION CKT EXAMPLE FOR HIGH CURRENT DRIVE

TYPICAL CHARACTERISTICS
DIFFERENTIAL OUTPUT VOLTAGE

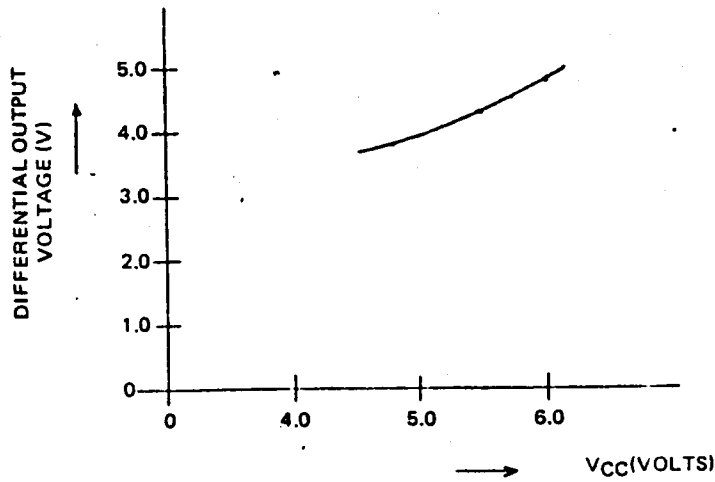

• 10 Ω LOAD
(PIN 11 & 13)
• $T_A = 25^\circ\text{C}$

OUTPUT SINK CURRENT VS OUTPUT VOLTAGE

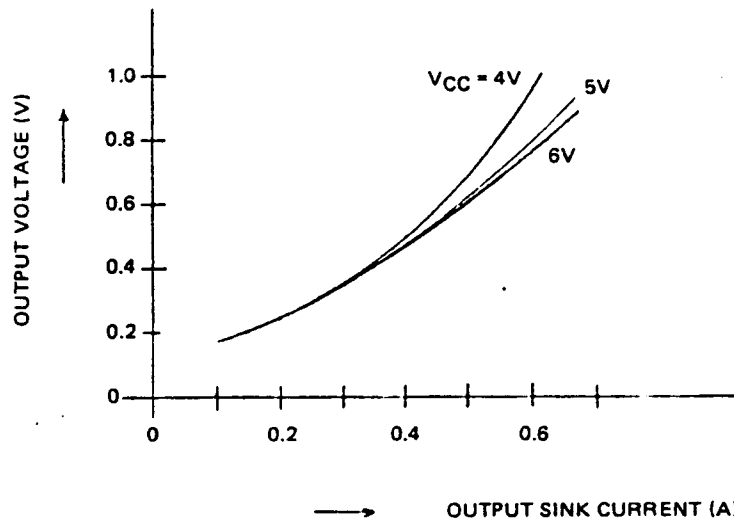

$T_A = 25^\circ\text{C}$

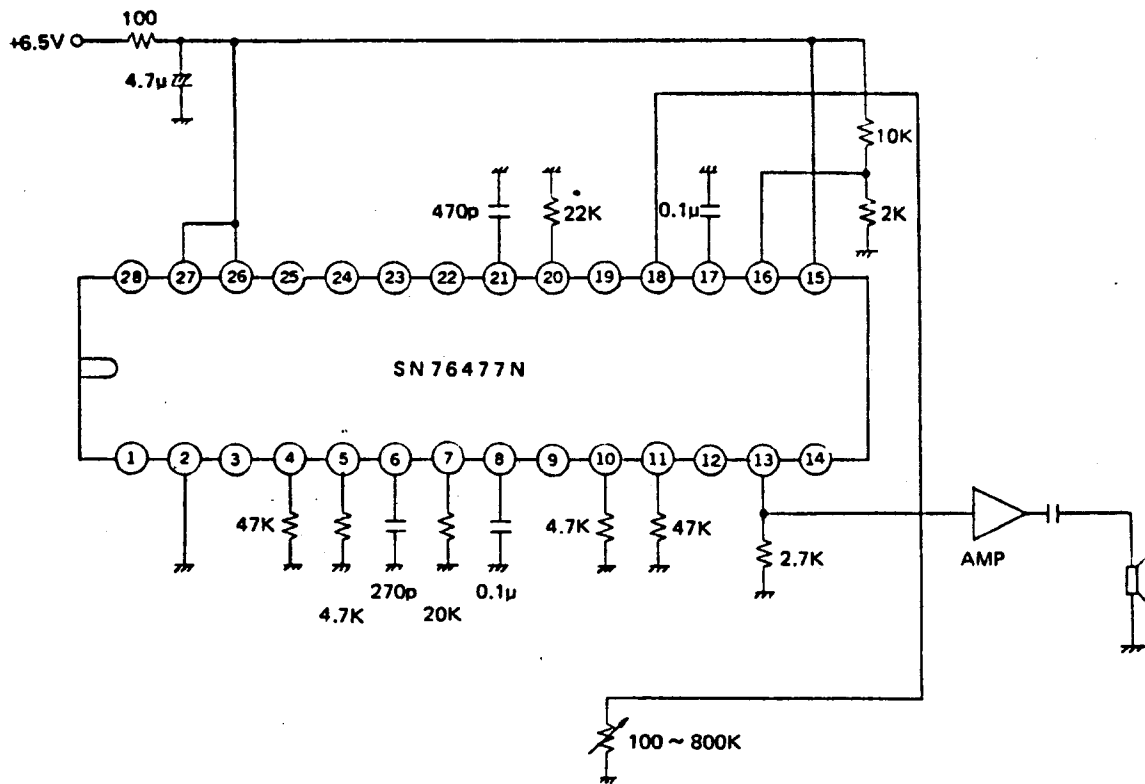

CAR ENGINE SOUND CKT EXAMPLE

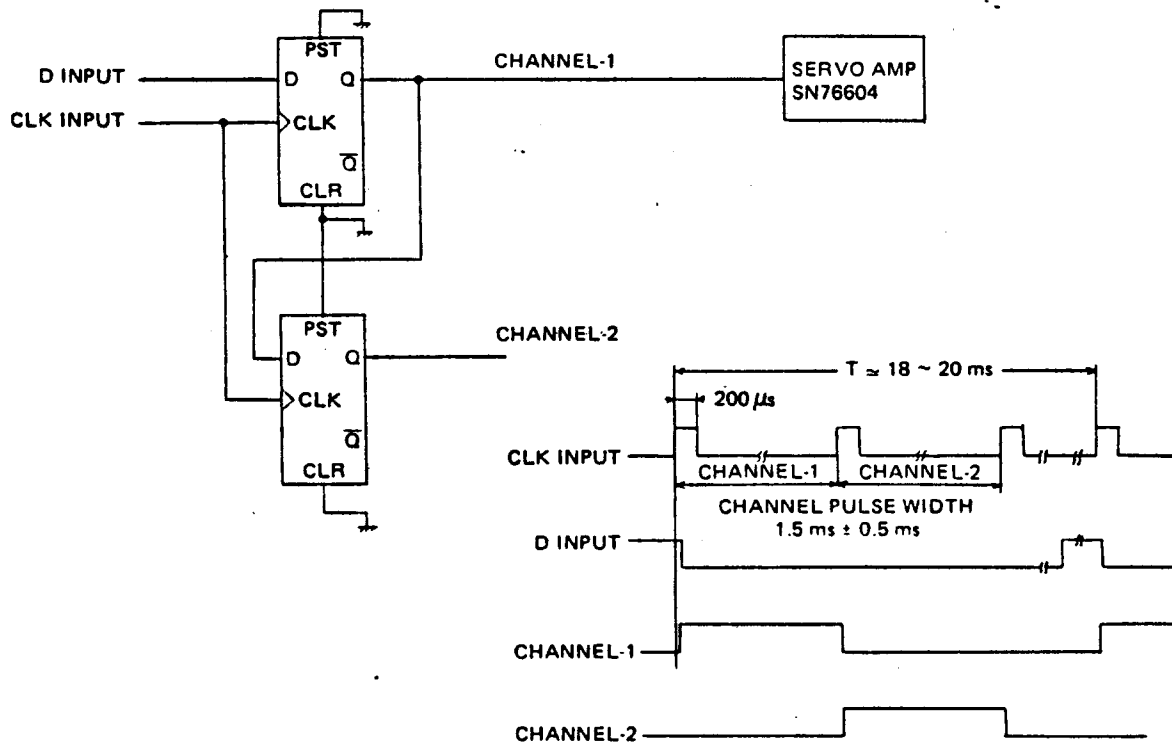

DECODER CKT FOR 2-CHANNEL DIGITAL PROPO