

RF4432 wireless transceiver module

1. Description

RF4432 adopts Silicon Lab Si4432 RF chip, which is a highly integrated wireless ISM band transceiver. The features of high sensitivity (-121 dBm), +20 dBm output power, 10PPM crystal, and good RF matching circuit make this module work well in hot/cold environment with reliable communication and long distance.

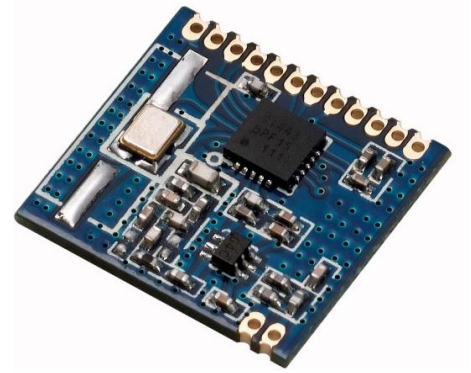

2. Features

- Frequency Range: 315/433/868/915 (Customizable 240-930 MHz)
- Sensitivity up to -121 dBm
- Data transfer rate: 0.123-256 kbps
- FSK and GFSK Modulation mode
- 1.8-3.6 V Power supply
- Ultra-low consumption shutdown mode
- Digital received signal strength indicator (RSSI)
- Time wake-up function
- Excellent antenna match circuit and bi-direction communication
- Configurable packet structure
- Preamble detection
- 64-byte transmit and receive data FiFo
- Low battery detection
- Temperature sensor and 8-bit analog-to-digital converters
- 10PPM crystal with operating Temperature Range: -40 ~ + 85 °C
- Integrated voltage regulator
- Frequency hopping
- Power-on reset function
- Built-in crystal adjustment function

3. Application

- Remote control
- Remote meter reading
- Home security alarm and remote keyless entry
- Sensor networks
- Industrial control
- Tire Pressure Monitoring
- Home automation telemetry
- Health Monitoring
- Personal data records
- Wireless PC peripherals
- Toy control
- Tag reader

4. Electrical Specifications

Parameter	Conditions	Min	Typ	Max	Units
Supply Voltage Range		1.8	3	3.6	V
Operating Temperature Range		-40		85	°C
Current in RX mode			18.5		mA
Current in TX mode	@20dBm		85		mA
Current in standby mode	Register values retained, Oscillator OFF		450	800	nA
Current in shut down mode	Register value lost, Oscillator off SDN pull high		15	50	nA
Frequency Range	@315MHZ	285	315	335	MHZ
	@433MHZ	403	433	463	MHZ
	@470MHZ	470	490	510	MHZ
	@868MHZ	838	868	898	MHZ
	@915MHZ	895	915	935	MHZ
Data Rate	FSK	0.123		256	Kbps
Output power		+1		+20	dBm
Rx Sensitivity	@data=1.2kbps,Fdev=20kHZ		-121		dBm

5. Schematic

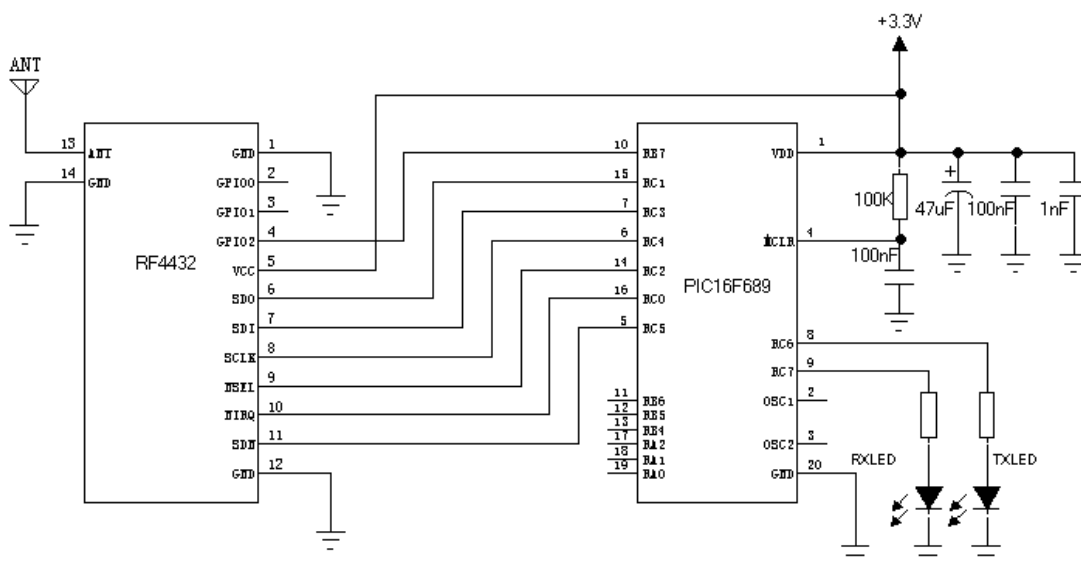

6. Pin Configuration

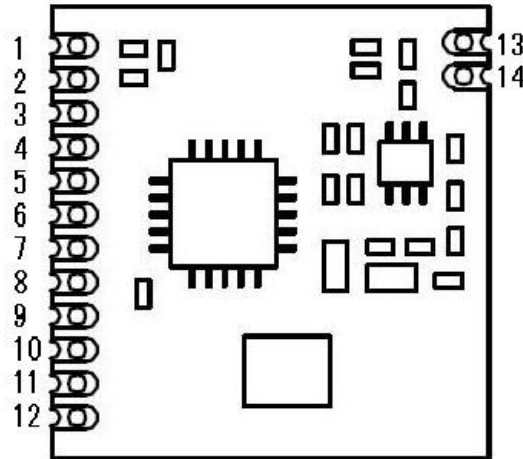

Pin Number	Pin Definitions	Description
1	GND	Connected to power ground
2	GPIO0	Connected to the antenna switch on the module. Control antenna in Tx, Rx and standby mode together with GPIO1
3	GPIO1	Connected to the antenna switch on the module. Control antenna in Tx, Rx and standby mode together with GPIO0
4	GPIO2	General IO port of Si4432
5	VCC	Positive supply 1.8--3.6V
6	SDO	Serial data out for SPI interface
7	SDI	Serial data in for SPI interface
8	SCLK	Serial data clock for SPI interface
9	nSEL	Serial data selection for SPI interfaces.
10	nIRQ	Interrupt output
11	SDN	Power down control. SDN = 1, power down SDN = 0, normal working.
12	GND	Connected to power ground
13	ANT	Connect with 50 ohm coaxial antenna
14	GND	Connected to power ground

7. Mechanism dimensions

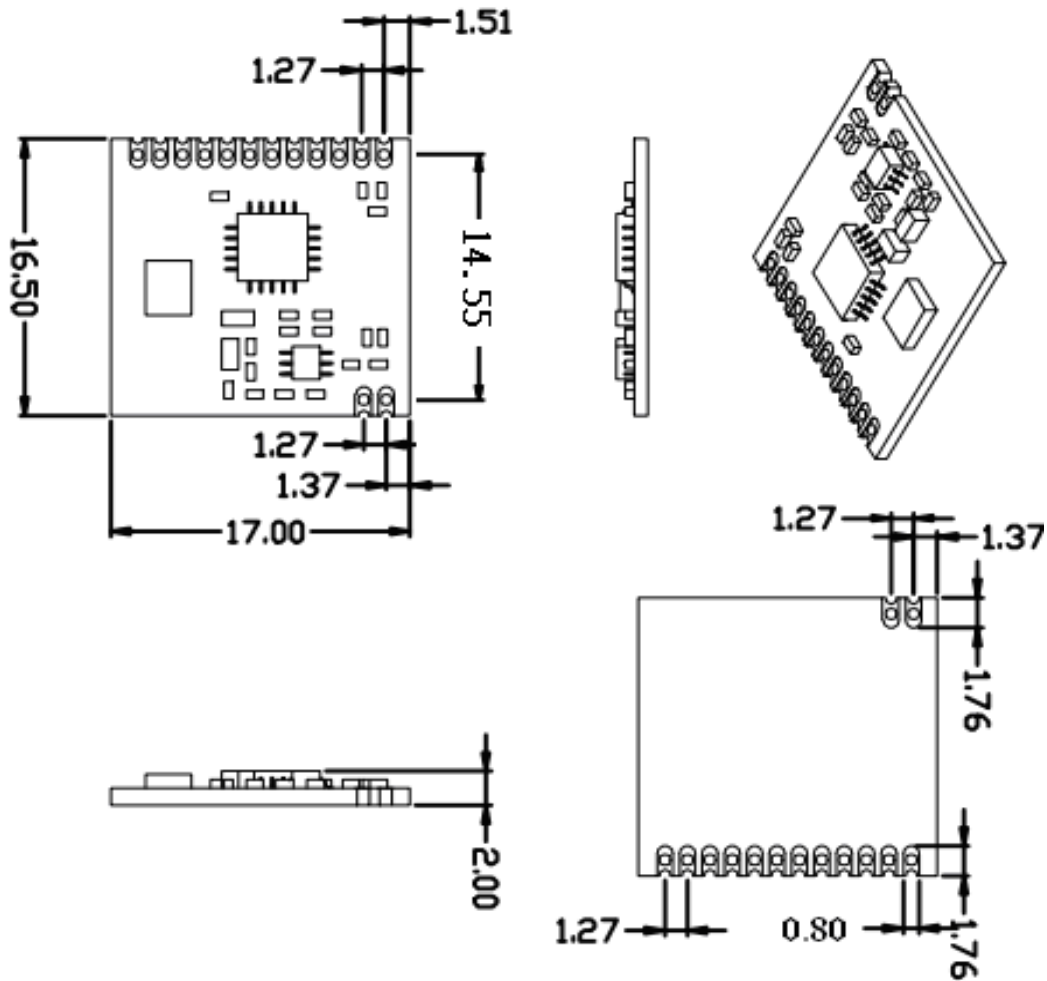

8. Products Ordering Information

RF4432 - 433



Module Model

Frequency

For example:

If the customer needs the patch module small crystal 433MHZ band module that order
 Model: RF4432 - 433

RF4432 products following models:

Part Number	Remark
RF4432-315	315MHZ,
RF4432-433	433MHZ,
RF4432- 868	868MHZ,
RF4432- 915	915MHZ,

Appendix:

The module is equipped with a standard DEMO board for customer to debug the program and test distance. It shows as below:

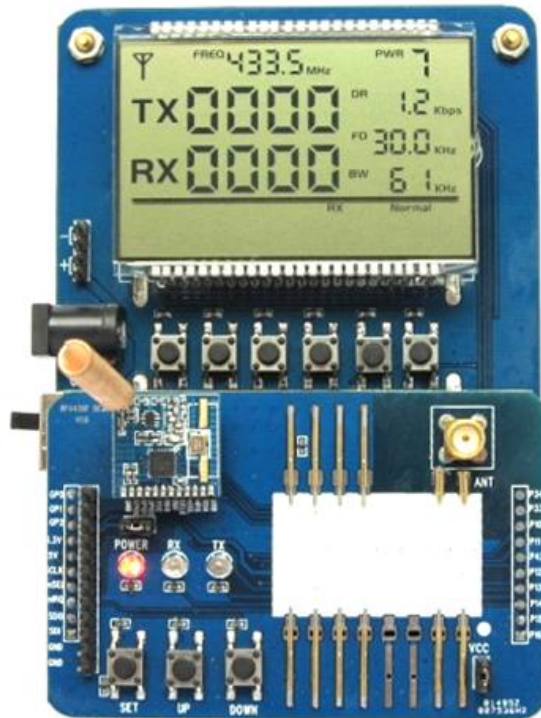

The LCD Full Segment is as below:

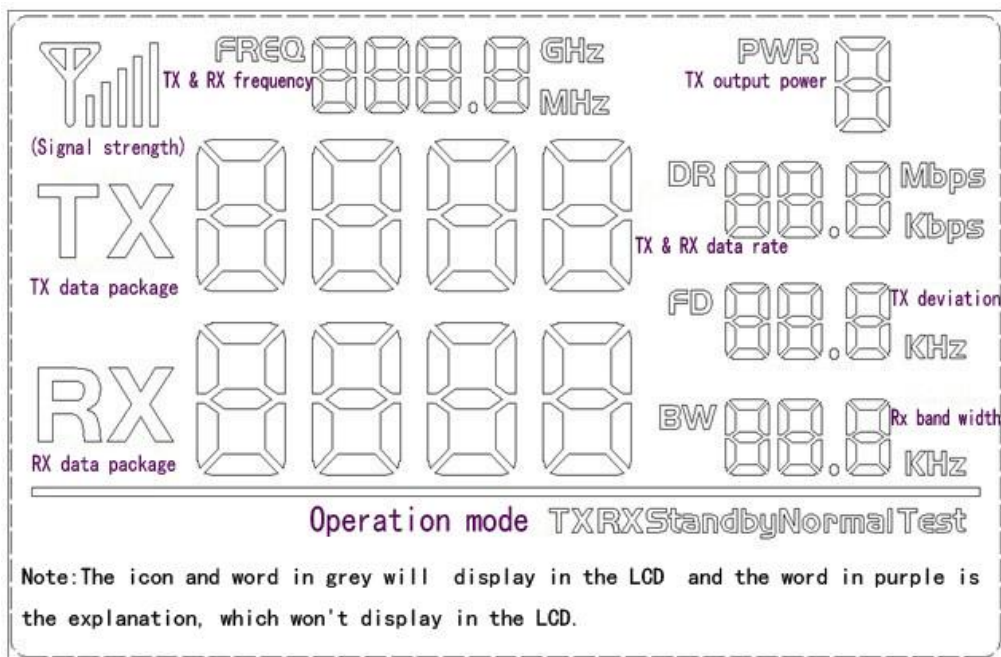

Users can set the parameters of the RF module such as frequency / transmitter power / transmission data rate / working mode through the buttons, and measure the wireless communication distance.

Also, all the connection Pins of the module are extended to the demo board, user can use oscilloscope, multi-meter to monitor the operation of the RF module, which is very useful for software programming.

➤ **Working Mode**

There are 5 working modes in the DEMO. They are: Master mode, Slave mode, Tx Test mode, Rx test mode, Standby mode, accordingly, they are displayed on the LCD as: Tx normal / Rx normal / Tx Test / Rx test / Standby. When one packet is transmitted, the Red LED will blink once, the number of Tx packets will increase; when one packet is received, the Blue LED will blink once, the number of Rx packets will increase.

- 1) Master Mode: Send 1 packet per second, and waiting for the acknowledge;
- 2) Slave Mode: Stay in Rx mode to wait for the data from the master, it will send back the acknowledged signal after receiving the data from the master.
- 3) Tx Test Mode: RF module continuously transmit signal;
- 4) Rx Test Mode: RF module is always in Rx mode;
- 5) Standby Mode: RF module is always in standby state.

➤ **Button Operation**

- 1) [SET] Button

Press the [SET] button to enter setting mode if not in setting mode. In setting mode, press [SET] button to toggle between the set parameters: frequency /output power / data rate / working mode. The related LCD ICON will flash to indicate.

- 2) [UP] Button

In setting mode, press the [UP] button to increase the value of flash icon.

- 3) [Down] Button

In setting mode, press the [Down] button to decrease the value of flash icon.

Note: The DEMO board has FLASH memory inside, all the setting parameters will be saved automatically and keep unchanged even power-off.