

SCHOTTKY BARRIER DIODE

Outline drawings, mm

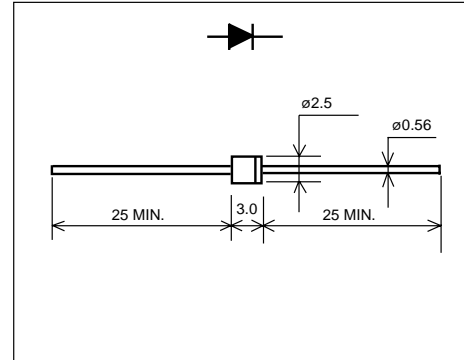

Features

- Low V_F
- Super high speed switching
- High reliability by planer design
- Ultra small package, possible for 5mm pitch automatic insertion

Applications

- High speed switching

Marking

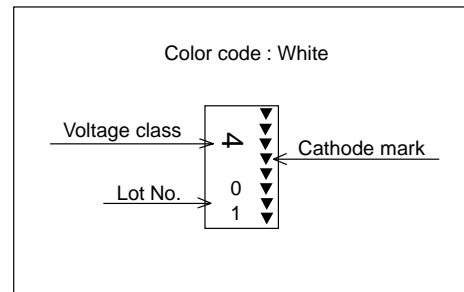

Maximum ratings and characteristics

- Absolute maximum ratings

Item	Symbol	Conditions	Rating	Unit
Repetitive peak reverse voltage	V_{RRM}		40	V
Non-repetitive peak reverse voltage	V_{RSM}	$t_w=500ns, duty=1/40$	48	V
Average forward current	$I_{F(AV)}$	Square wave, $duty=1/2$ $T_I=115^\circ C$	1.0*	A
Surge current	I_{FSM}	Sine wave 10ms	50	A
Operating junction temperature	T_j		-40 to +150	$^\circ C$
Storage temperature	T_{stg}		-40 to +150	$^\circ C$

* Mounted on printed circuit board (10 x 10mm)

- Electrical characteristics ($T_a=25^\circ C$ Unless otherwise specified)

Item	Symbol	Conditions	Max.	Unit
Forward voltage drop	V_{FM}	$I_{FM}=1A$	0.55	V
Reverse current	I_{RRM}	$V_R=V_{RRM}$	2.0	mA

Characteristics

