

TITLE DC JACK	SPC. NO. KM02006	PAGE : 1 OF 7 DATE : 2003.12.23
-------------------------	----------------------------	--

1. Scope

This specification applies to unified polarity type DC jack (Type 1 ② 3 4) used in electronic equipment.

For DC input use.

Applicable Safety Standard / Applicable Standard

Applicable Safety Standard : Electrical Applicable and Material Control Law (Technical Requirement)

Applicable Standard : EIAJ RC-5320 "Plugs and jacks for coupling an external voltage power supply"
(Unified polarity type)

3. Polarity

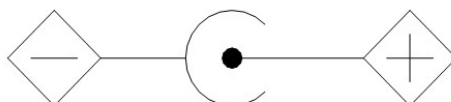

4. Standard atmospheric conditions

Unless otherwise specified. The standard range of atmospheric condition for making measurements and tests are as follows :

Ambient temperature : 5°C to 35°C

Relative humidity : 45% to 85%

Air pressure : 86kPa to 106kPa

If there is any doubt about the results, measurements shall be made within the follow limits :

Ambient temperature : 20±2°C

Relative humidity : 60% to 70%

Air pressure : 86kPa to 106kPa

Storage Temperature Range : -20°C to 80°C

Operating Temperature Range: -10°C to 75°C

Operating temperature range is the range of ambient temperature for the component that can be operated continuously at rated voltage and rated current.

ISSUE	DATE	WRN	CHKD	APVD	DESCRIPTIONS
	2003.12.23	陳樹民	龔雲輝	龔雲輝	
△x2	2008.01.24	劉秀慧	夏正雄	郭遠峰	Solderability 245°C→250°C
△x2	2008.12.08	黃健瑋	夏正雄	夏正雄	Add statement of shelf life and test group
△x1	2012.08.14	江浩霆	郭素玲	郭素玲	Modify the item 7.2
△x1	2017.07.25	李阮龍	郭遠峰	郭遠峰	Modify the item 9

TITLE		SPC. NO.	PAGE : 2 OF 7
DC JACK		KM02006	DATE : 2003.12.23
5.Mechanical characteristics			
	Item	Condition	Specifications
1	Operating force	Measurement shall be made after insertion and withdrawal using standard plug gauge 3 times.	
		Insertion force	19.6N (2kgf MAX)
		Withdrawal force	2.95~14.7 N (0.3~1.5kgf)
2	Terminal strength	A static load of 4.9N (500gf) shall be applied to the tip of the terminal for 10 sec in any direction.	There shall be no damage to the terminal such as cracks, looseness or play. Electrical and mechanical characteristics shall be satisfied.
6.Electrical characteristics			
	Item	Condition	Specifications
1	Rated voltage/ Rated current	Type 1	DC 3.15V 2A
		Type 2	DC 6.3V 2A
		Type 3	DC 10.5V 2A
		Type 4	DC 13.5V 2A
2	Contact resistance	Measurement shall be made at with small current 1000 Hz (100mA MAX.)	30 mΩ MAX.
3	Insulation resistance	Apply a voltage of 500V DC for 1 min. to following portions after which measurement shall be made : Between body and conductor Between conductors not to be contact Between conductors not to be contact when plug is inserted	100MΩ MIN.
4	Dielectric strength	AC 500V (60Hz) For 1 minute. Trip current : 2mA Between body and conductor Between conductors not to be contact Between conductors not to be contact when plug is inserted	Without damage such as insulation breakdown
7. Endurance characteristics			
	Item	Condition	Specifications
1	Solderability	Temperature of solder : $\Delta 250^{\circ}\text{C} \pm 5^{\circ}\text{C}$ Time of dip : 3 ± 0.5 seconds Length of dip : $2 \pm 0.5\text{mm}$ (from top of terminal)	The soldered area shall be covered a minimum of 90% of the surface being immersed.

TITLE DC JACK	SPC. NO. KM02006	PAGE : 3 OF 7 DATE : 2003.12.23
-------------------------	----------------------------	--

Item	Condition	Specifications		
2 Resistance to Soldering Heat Test ⚠	Wave soldering Process	Electrical and mechanical characteristics shall be satisfied, and not show remarkable failure.		
	Profile Feature		Pb-Free Assembly	
			Topside PCB	Padside PCB
	Preheat -Temperature min -Temperature max -Time (t _s min to max)		120°C (T _{sl} max)	110°C (T _s min) 150°C (T _s max) 75 sec
	Peak/Classification Temperature		165°C (T _{pl} max)	260°C ±5°C (T _p)
	Time within 5°C of actual Temperature (t _p)			10 sec (within 2 times every time 2-3 sec)
	Time 25°C to Peak temperature			3 minutes max
	Wave Soldering Temperature Profile are as below	⚠About the plastic properties , Please refer to the data sheet of plastic.		
	<p>Temperature vs Time graph showing wave soldering profiles for Topside PCB (dashed red line) and Padside PCB (solid blue line). The graph includes parameters: Ts min., Ts max., Tp, Tp1 max., Ts1 max., ts (Time to Peak), and tp (Peak Time). The peak time tp is indicated as 2~3 sec.</p>			
	Soldering Iron Test Temperature of soldering Iron : 380±10°C Soldering time : 3±1 seconds		Same as Wave soldering Process	
Insertion force		19.6N (2kgf MAX)		
Withdrawal force		2.95~14.7 N (0.3~1.5kgf)		

TITLE DC JACK	SPC. NO. KM02006	PAGE : 4 OF 7 DATE : 2003.12.23
-------------------------	----------------------------	--

Item	Condition	Specifications
3	Low temperature The jack shall be stored at a temperature of $-25^{\circ}\text{C} \pm 3^{\circ}\text{C}$ for 2 hours. And then it shall be subjected to the controlled recovery conditions for 1 hour after which measurement shall be made.	Mechanical and electrical characteristics shall be satisfied. There shall be no damage on appearance.
4	High temperature The jack shall be stored at a temperature of $85^{\circ}\text{C} \pm 2^{\circ}\text{C}$ for 96 hours. And then it shall be subjected to the controlled recovery conditions for 1 hour after which measurement shall be made.	Mechanical and electrical characteristics shall be satisfied. There shall be no damage on appearance.
5	Composite temperature / humidity cyclic test The jack shall be subject to 10 continuous cycles each as shown in figure below. Then the jack shall be stored at standard atmospheric conditions for 24 hours recovery after which measurement shall be made. ※Temperature shall be reduced from 25°C to -10°C within 30 min. ※Humidity uncontrolled at a temperature less than 25°C	Mechanical and electrical characteristics shall be satisfied. There shall be no damage on appearance.

TITLE DC JACK	SPC. NO. KM02006	PAGE : 5 OF 7 DATE : 2003.12.23
-------------------------	----------------------------	--

	Item	Condition	Specifications	
6	Sulfuration	The terminals of miniature jack shall be dipped into a dilute solution of 3% potassium sulfide for 1 minute.	60mΩ MAX.	
7	Operating endurance	Without load : Insertion and withdrawal shall be made with the mating plugs and jacks for 5000 cycles at a speed of 10~20 cycles/min.		
		Load : At rating condition (non-inductive load) Insertion and withdrawal shall be made 1000 cycles at a speed of 10~20 cycles/min.		
		Insertion force		19.6N (2kgf) MAX.
		Withdrawal force		1.96~14.7 N (0.2~1.5kgf)
		Contact resistance	60mΩ MAX.	

△8. Soldering condition shelf life about 6 months depend on storage condition of humidity, temperature and others factors.

TITLE DC JACK	SPC. NO. KM02006	PAGE : 6 OF 7 DATE : 2003.12.23
-------------------------	----------------------------	--

9. \triangle Mating plug

TYPE 2
$3.15V < RV \leq 6.3V$
RV=Rated voltage

Figure of mating plug

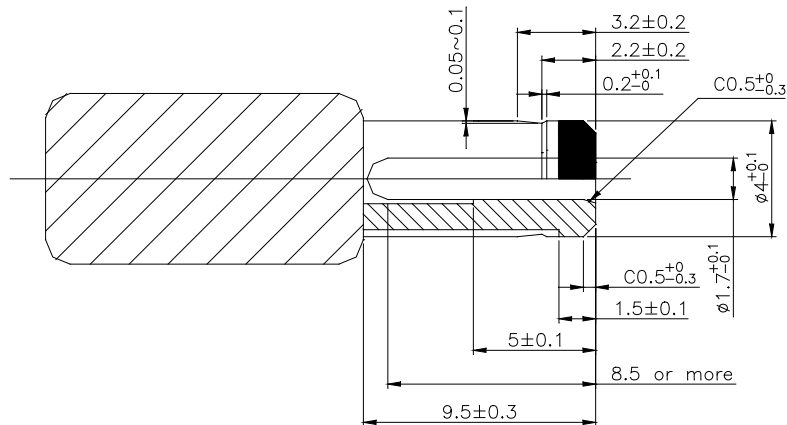

UNIT : mm

TITLE DC JACK	SPC. NO. KM02006	PAGE : 7 OF 7 DATE : 2003.12.23
-------------------------	----------------------------	--

10. Endurance test sequence :

Test Item		Test group							
		A	B	C	D	E	F	G	H
5.1	Operating force	1,6		1,6	1,6	1,6	1		1
5.2	Terminal strength	5							
6.2	Contact resistance	2,7		2,7	2,7	2,7	2,6	1	2
6.3	Insulation resistance	3,8		3,8	3,8	3,8	3,7		3,6
6.4	Dielectric strength	4,9		4,9	4,9	4,9	4,8		4,7
7.1	Solderability		1						
7.2	Resistance to Soldering Heat Test			5					
7.3	Low temperature				5				
7.4	High temperature					5			
7.5	Composite temperature/ humidity cyclic test						5		
7.6	Sulfuration							2	
7.7	Operating endurance								5

Test sample quality : 2 pcs min. / group