

PRDUCT SPECIFICATON
TFT LCD MODULE
Model : ELT240320ATP



2.8 inch TFT LCD with Touch Screen

This specification is subject to change without notice.

Contents Page

1. LCM Specification.....	3
2. Functional Block Diagram.....	4
3. Mechanical Specification.....	5
4. Electrical Units.....	6
5. AC Characteristics.....	9
6. Optical Specifications.....	13
7. Reliability Test Items.....	16
8. Package(TBD).....	16
9. Handling Precautions.....	17

MODEL NO **ELT240320ATP**

1. LCM Specification

1.1 Description

ELT240320ATP is a transmissive type color active matrix liquid crystal display (LCD) which uses amorphous thin film transistor (TFT) as switching devices. This product is composed of a TFT LCD panel, a drive IC, a FPC, and a WLED-backlight unit. The active display area is 2.8 inches diagonally measured and the native resolution is 240*RGB*320. Features of this product are listed in the following table.

1.2 Functions & Features

Table1.1 Module Functions & Features

Parameter	Value	Unit
LCD Mode	a-Si TFT/transmissive	-
Color	262K	-
Display Resolution	240*RGB*320	pixels
OUTLINE DIMENSIONS	50.00(W) x69.20(H) x4.05(T)	mm
Active Area(A.A)	43.20 (W) x 57.60(H)	mm
Pixel Arrangement	RGB-stripe	-
Viewing Direction	12 O'clock	
Display Mode	Normally white	
LCD Controller/Driver	ILI9325	-
IC Package Type	COG	-
MPU interface	Standard 8080 system18-/16-bit parallel	-
Power Supply Voltage	2.5~3.3	V
Back-light	White LED*4	pcs

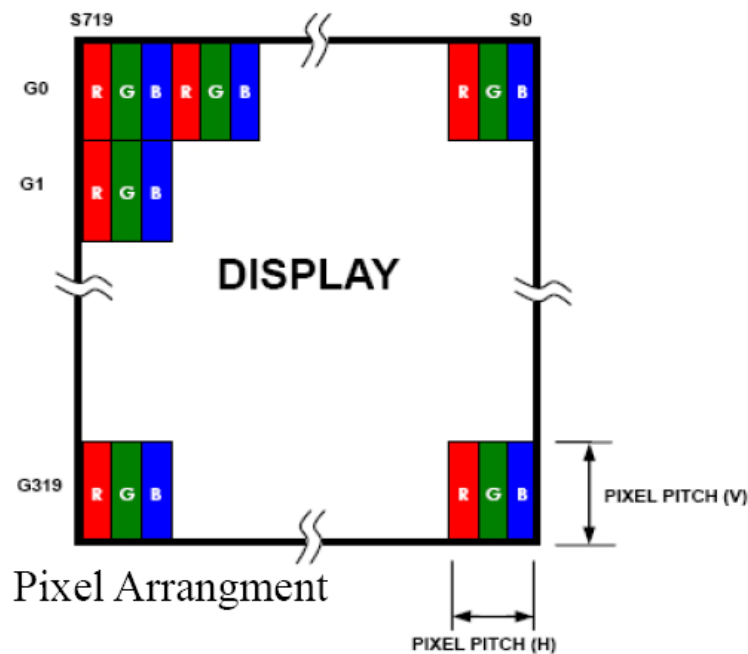

MODEL NO ELT240320ATP

2. Functional Block Diagram

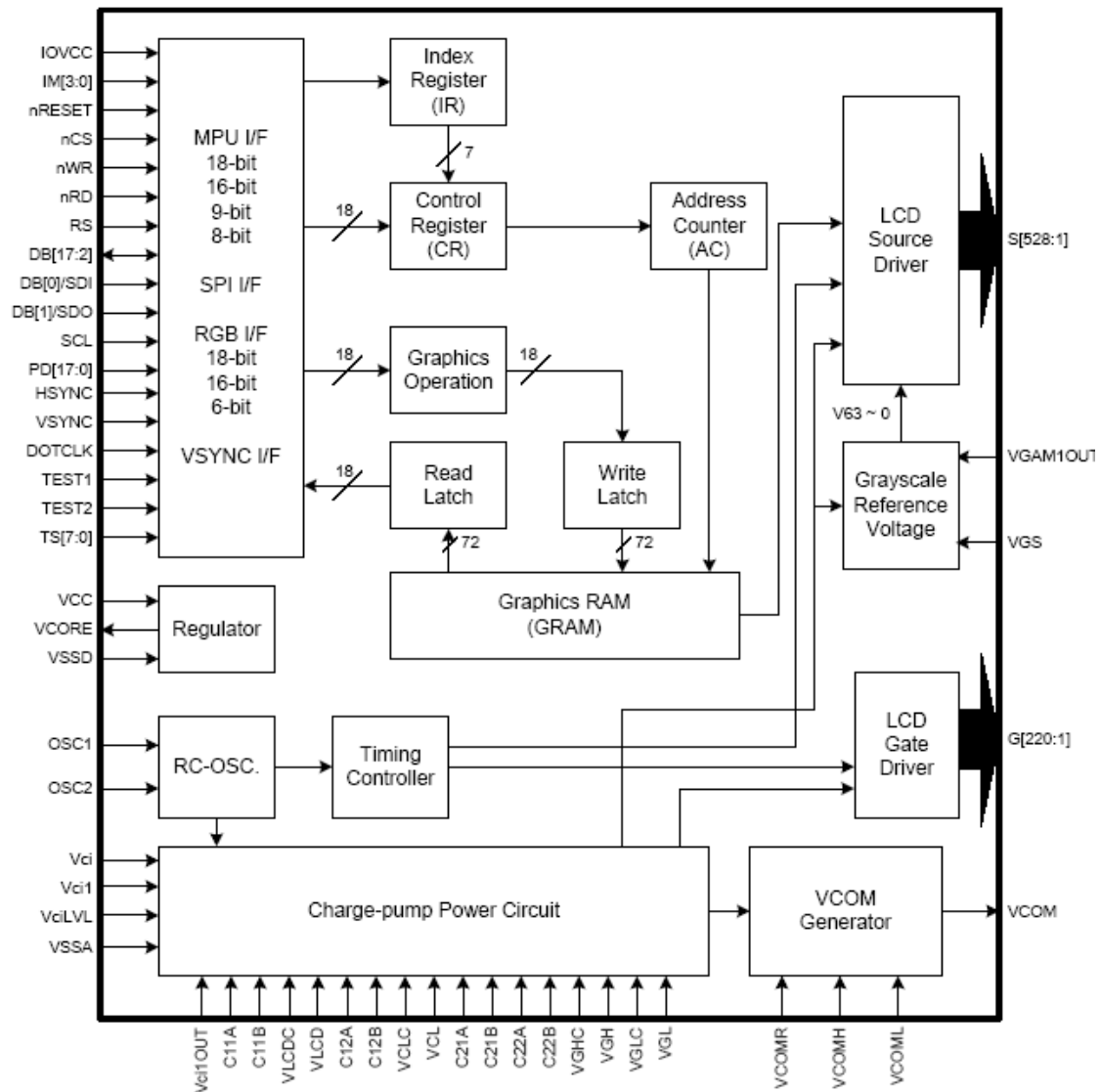

MODEL NO ELT240320ATP

3. Mechanical Specification

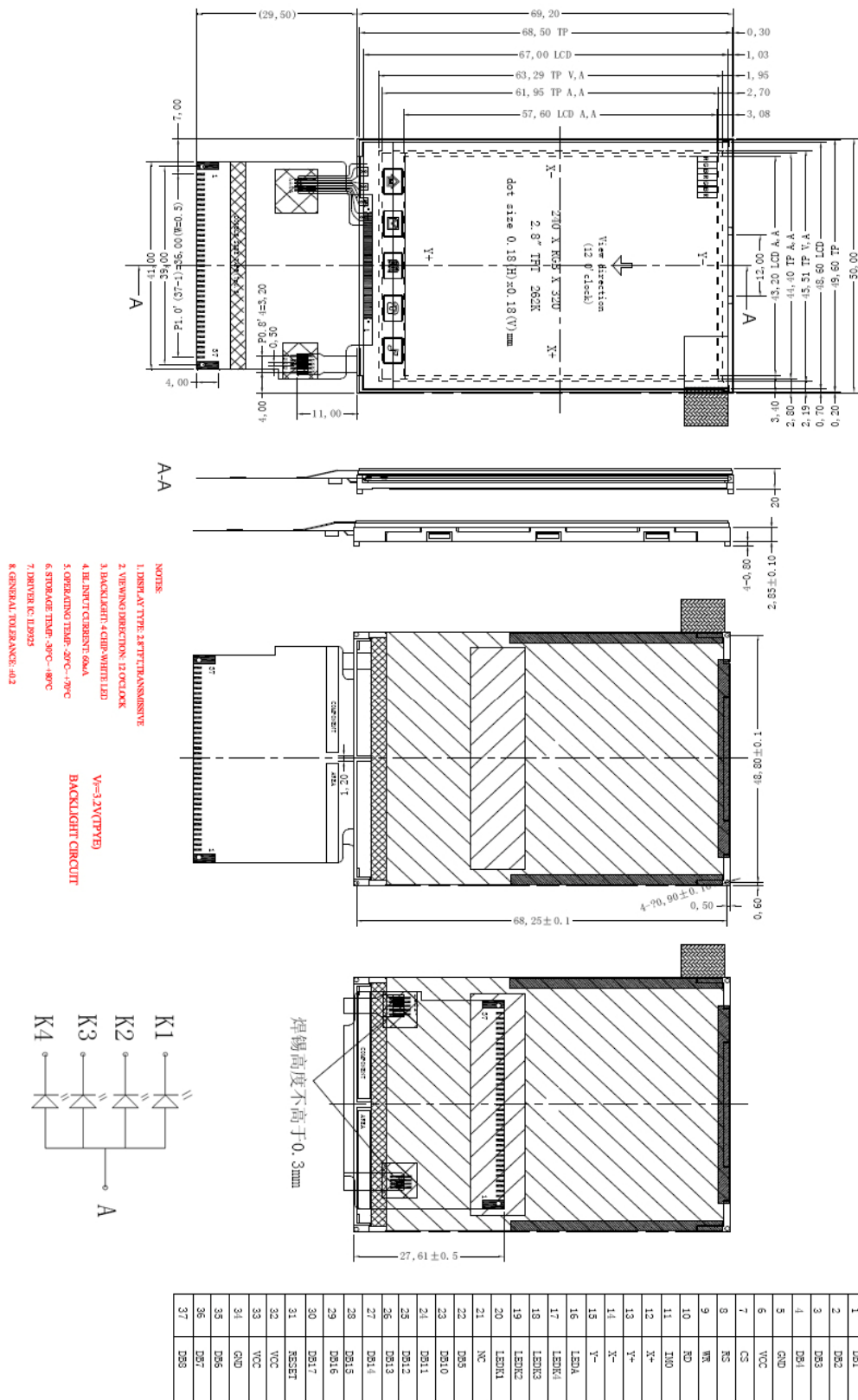

MODEL : ELT240320ATP

MODEL NO ELT240320ATP

4. Electrical Units

4.1 Electrical Specification

4.1.1 Absolute Maximum Ratings

The absolute maximum ratings are list on Table 4.1. When used out of the absolute maximum ratings, the LCM may be permanently damaged. Using the LCM within the following electrical characteristics limit is strongly recommended for normal operation. If these electrical characteristic conditions are exceeded during normal operation, the LCM will malfunction and cause poor reliability.

Table 4.1 Module Absolute Maximun Ratings

Item	Symbol	Unit	Value	Note
Power supply Voltage(1)	Vcc	V	-0.3~4.0	
Power supply Voltage(2)	Vci~VSS	V	2.5~3.3	
Power supply Voltage(3)	VGH~Vss	V	10~20	
Power supply Voltage(4)	VSS~VGH	V	10~20	-
Inout Voltage	Vi	V	-0.3 to Vcc+0.3	
Operating Temperature	Top	°C	-20 to +70	
Storage Temperature	Tst	°C	-30 to +80	

(VSS=0V)

MODEL NO **ELT240320ATP**

4.2 Pin Descriptions

4.2.1 TFT LCD Panel interface FPC Pin Description

No.	Symbol	Functional	Remark
1	DB1	Data bus	
2	DB2	Data bus	
3	DB3	Data bus	
4	DB4	Data bus	
5	GND	Ground	
6	VCC	Power	
7	CS	Chip select pin of serial inter face	
8	RS	Data or command	
9	WR	Write signal	
10	RD	Read signal	
11	IMO	Interface mode select	
12	X+	Touch panel X+	
13	Y+	Touch panel Y+	
14	X-	Touch panel X-	
15	Y-	Touch panel Y-	
16	LED-A	LED A	
17	LED-K4	LED K4	
18	LED-K3	LED K3	
19	LED-K2	LED K2	
20	LED-K1	LED K1	
21	NC	No connection	
22	DB5	Data bus	
23	DB10	Data bus	
24	DB11	Data bus	
25	DB12	Data bus	
26	DB13	Data bus	
27	DB14	Data bus	
28	DB15	Data bus	
29	DB16	Data bus	
30	DB17	Data bus	
31	REST	Reset dim	
32	VCC	Power	
33	VCC	Power	
34	GND	Ground	
35	DB6	Data bus	
36	DB7	Data bus	
37	DB8	Data bus	

Note :

ELT240320ATP , LCD driver migrating from ILI9320 to ILI9325

- PIN IM0 when the IM0=0, it is for 16bit, and when the IM0=1, it is for 8bit.(DB10-DB17) . By the way, there are three resistances on the screen, when you solder the R1, it is for 8bit, when you solder the R2, it is for 16bit, and when you solder the R3, it is controlled by the IM0 which you can select for either 8bit or 16bit.

- PIN 21 no connection

MODEL NO **ELT240320ATP**

4.3 Electrical characteristics (Ta=25°C)

4.3.1 DC characteristics

Table 4.2:DC Characteristic(Vcc=2.4~3.3V,Ta=0~60°C)

Item	Symbol	Unit	Test Conditon	Min	Typ.	Max	Note
Input hight voltage	V _{IH}	V	V _{cc} =1.8~3.3V	0.8xIOV _{CC}	-	IOV _{cc}	-
Input low voltage	V _{IL}	V	V _{cc} =1.8~3.3V	-0.3V	-	0.2xIOV _c	-
I/O leakage current	I _{Li}	mA	V _{in} =0~V _{cc}	-0.1	-	0.1	-
Current consumption during normal operation(V _{cc} -V _{SS})	IOP(V _{cc})	mA	V _{ci} =V _{cc} =2.8V,Ta=25°C,fOSC=376KHz(Line)GRAM data=0000h,Frame rate=70Hz,REV=0,SAP=100,AP=100,DC0=000,DC1=010,B/C=0,BT=001,VC=001,VRH=0011,VCM=10011,VDV=10000,VCOMG=1,CL=0, No panel load	-	100(V _{CC})	-	-
Current consumption during normal operation (V _{ci} -V _{SS})	IOP(V _{ci})	mA		-	100(V _{CC})	-	-
Current consumption during standby mode (V _{cc} -V _{SS})	Ist(V _{cc})	mA	V _{cc} =2.8V,Ta=25°C	-	5	10	-
Current consumption during standby mode (V _{ci} -V _{SS})	Ist(V _{ci})	mA		-	5	10	-
Output voltage deviation	-	mV	-	-	5	-	-
Dispersion of the Average Output Voltage	V	mV	-	-	-	35	-

MODEL NO **ELT240320ATP**

4.4 Back-light Specification

Table 4.3 Back-light Specification

Item	Symbol	Min.	Typ.	Max.	Unit	Remark
Supply Voltage	VBAT	-	3.2	3.4	V	Note
Formard current	If	-	15	-	mA	
Power Consumption	PBL-		180	-	mW	Note

Note:

Table 4.4 Back-light Specification

Item	Symbol	Conditions	Min.	Typ.	Max.	Unit
Supply Voltage	VF	Only Backlight	3.0	3.2	3.4	V
Supply Current	IF		15x4=60			mA
Average Brightness (With LCD dots all on)	IV	Backlight Current IF=15mA	-	2800	-	Cd/m ²
CIE Color Coordinate (Without LCD)	X	Backlight Current IF=15mA	0.24	-	0.29	-
	Y		0.24	-	0.29	
Uniformity	B	Backlight Current IF=15mA	80	-	-	(%)
Color	White					

5. AC Characteristics

5.1.1 Clock Characteristics

Item	Symbol	Unit	Min.	Typ.	Max.	Test Condition
External clock frequency	Fcp	KHz	T.B.D	335	T.B.D	Vcc=2.4~3.3V
External clock duty ratio	Duty	%	45	50	55	Vcc=2.4~3.3V
External clock rise time	Trcp	s	-	-	0.2	Vcc=2.4~3.3V
External clock fall time	Tfcp	s	-	-	0.2	Vcc=2.4~3.3V
R-C oscillation clock	fOSC	KHz	275	335	395	Rf=130KΩ, Vcc=2.8V

Table 5.1:Clock Characteristics (Vcc=2.4~3.3V)

MODEL NO **ELT240320ATP**

5.1.2 8080 System (16bits)Bus Interface Timing Characteristics

Item		System	Unit	Min.	Typ.	Max.	Test Condition
Bus cycle time	Write	tCYCW	ns	300	-	-	Figure5.1
	Read	tCYCW	ns	500	-	-	Figure5.1
Write low-level pulse width		PWLW	ns	40	-	-	Figure5.1
Read low-level pulse width		PWLR	ns	250	-	-	Figure5.1
Write high-level pulse width		PWHW	ns	30	-	-	Figure5.1
Read high-level pulse width		PWHR	ns	200	-	-	Figure5.1
Write / Read rise / fall time		TWRr, TwRf	ns	-	-	25	Figure5.1
Setup time	Write(RS to NCS,E_NWR)	tAS	ns	5	-	-	Figure5.1
	Read(RS to NCS,RW_NRD)	tAS		5	-	-	Figure5.1
Address hold time		tAH	ns	5	-	-	Figure5.1
Write data setup time		tDSW	ns	15	-	-	Figure5.1
Write data hold time		tH	ns	15	-	-	Figure5.1
Read data delay time		tDDR	ns	-	-	80	Figure5.1
Read data hold time		tDHR	ns	5	-	-	Figure5.1

Table 5.2:Normal Write Mode(HWM=0)/(Vcc=2.4~3.3V)

Item		System	Unit	Min.	Typ.	Max.	Test Condition
Bus cycle time	Write	tCYCW	ns	100	-	-	Figure5.1
	Read	tCYCW	ns	500	-	-	Figure5.1
Write low-level pulse width		PWLW	ns	40	-	-	Figure5.1
Read low-level pulse width		PWLR	ns	250	-	-	Figure5.1
Write high-level pulse width		PWHW	ns	30	-	-	Figure5.1
Read high-level pulse width		PWHR	ns	200	-	-	Figure5.1
Write Read/ rise/fall time		WRr, tWRF	ns	-	-	25	Figure5.1
Setup time	Write(RS to NCS,E_NWR)	tAS	ns	5	-	-	Figure5.1
	Read(RS to NCS,RW_NRD)		ns	5	-	-	Figure5.1
Address hold time		tAH	ns	5	-	-	Figure5.1
Write data setup time		tDSW	ns	15	-	-	Figure5.1
Write data hold time		tH	ns	20	-	-	Figure5.1
Read data delay time		tDDR	ns	-	-	200	Figure5.1
Read data hold time		tDHR	ns	5	-	-	Figure5.1

Table 5.3 High-Speed Write Mode (HWM=1)/(Vcc=2.4~3.3V)

MODEL NO ELT240320ATP

5.1.3 80-system(8Bits) Bus Interface Timing Characteristics

Item		Symbol	Unit	Min.	Typ.	Max.	Test Condition
Bus cycle time	Write	tCYCW	ns	300	-	-	Figure5.1
	Read	tCYCW	ns	500	-	-	Figure5.1
Write low-level pulse width		PWLW	ns	40	-	-	Figure5.1
Read low-level pulse width		PWLR	ns	250	-	-	Figure5.1
Write high-level pulse width		PWHW	ns	30	-	-	Figure5.1
Read high-level pulse width		PWHR	ns	200	-	-	Figure5.1
Write Read/ rise/fall time		WRr, tWRF	ns	-	-	25	Figure5.1
Setup time	Write(RS to NCS,E_NWR)	tAS	ns	5	-	-	Figure5.1
	Read(RS to NCS,RW_NRD)		ns	5	-	-	Figure5.1
Address hold time		tAH	ns	5	-	-	Figure5.1
Write data setup time		tDSW	ns	15	-	-	Figure5.1
Write data hold time		tH	ns	20	-	-	Figure5.1
Read data delay time		tDDR	ns	-	-	120	Figure5.1
Read data hold time		tDHR	ns	5	-	-	Figure5.1

Table 5.4 Normal Write Mode(HWM=0)/(Vcc=2.4~3.3V)

5.2 Timing Characteristic

5.2.1 8080 System Bus Operation

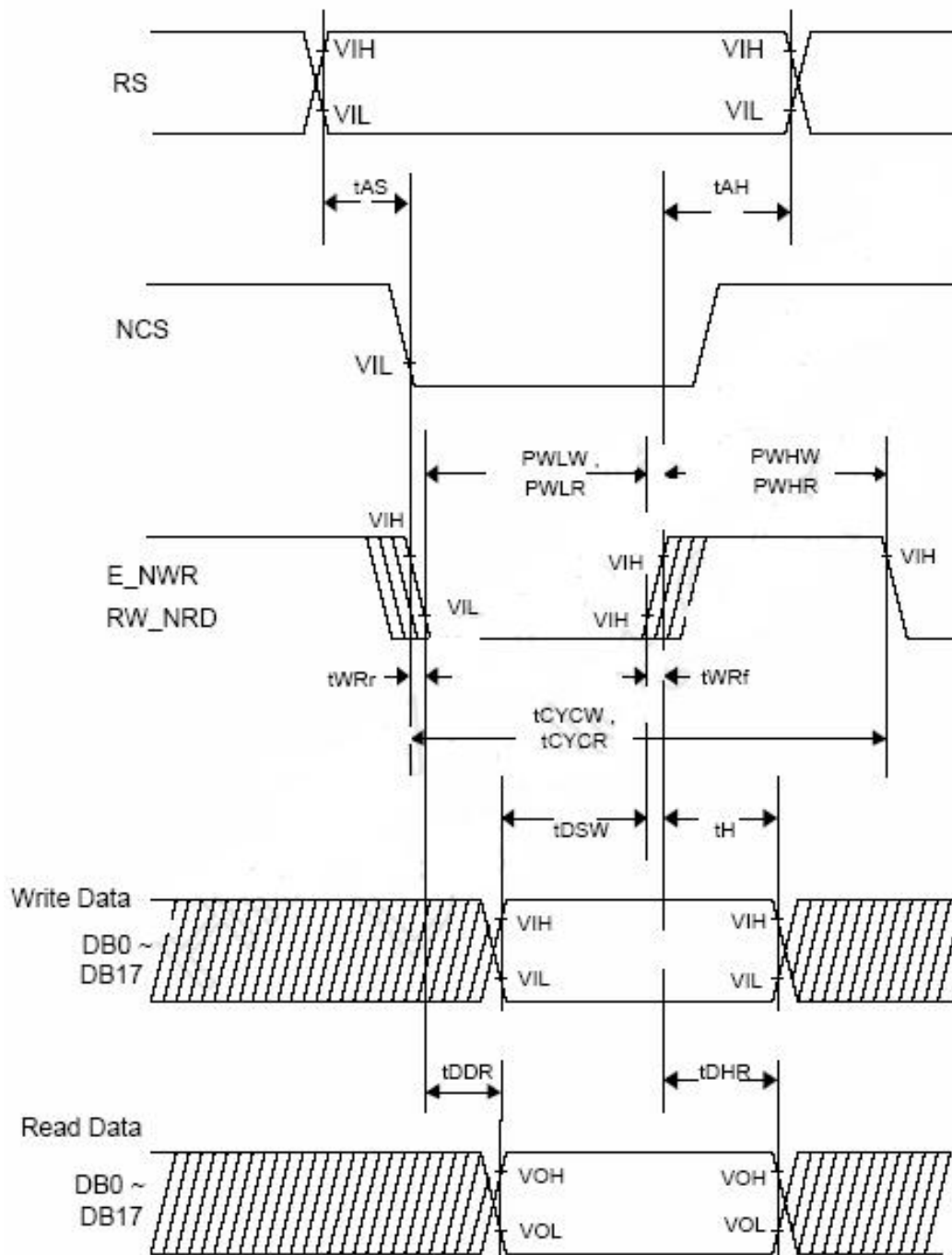

Figure 5.1:8080 System Bus Timing

MODEL NO **ELT240320ATP**

6. Optical Specifications

Item	Symbol	Conditions	Specifications			Unit	Note	
			Min.	Typ.	Max.			
Transmittance	T%	Viewing normal angle $\theta_x = \theta_y = 0^\circ$		6.0		%	All left side data are based on CMO's following condition -- Type 6 NTSC: 58% LC: 5001 Light : C light (Machine:BM5A) Polarizer without DBEF Reference Only	
Contrast Ratio	CR		150	250	-	--		
Response Time	T _R		-	15	30	ms		
	T _F		-	35	50	ms		
Chromaticity	Red		X _R	0.610	0.640	0.670		
			Y _R	0.314	0.344	0.374		
	Green		X _G	0.268	0.298	0.328		
			Y _G	0.553	0.583	0.613		
	Blue		X _B	0.102	0.132	0.162		
			Y _B	0.107	0.137	0.167		
White	X _W	0.282	0.312	0.342				
	Y _W	0.319	0.349	0.379				
Viewing Angle	Hor.	θ_{x+}	-	45		deg.		
		θ_{x-}	-	45				
	Ver.	θ_{y+}	-	35				
		θ_{y-}	-	15				

NOTE (1) Definition of Contrast Ratio(CR):

The contrast ratio can be calculated by the following expression.

$$\text{Contrast Ratio (CR)} = L_{63} / L_0$$

L63: Luminance of gray level 63

L0: Luminance of gray level 0

CR = CR (10)

CR (X) is corresponding to the Contrast Ratio of the point X at Figure in Note (6).

MODEL NO ELT240320ATP

Note (2) Definition of Response Time (TR, TF):

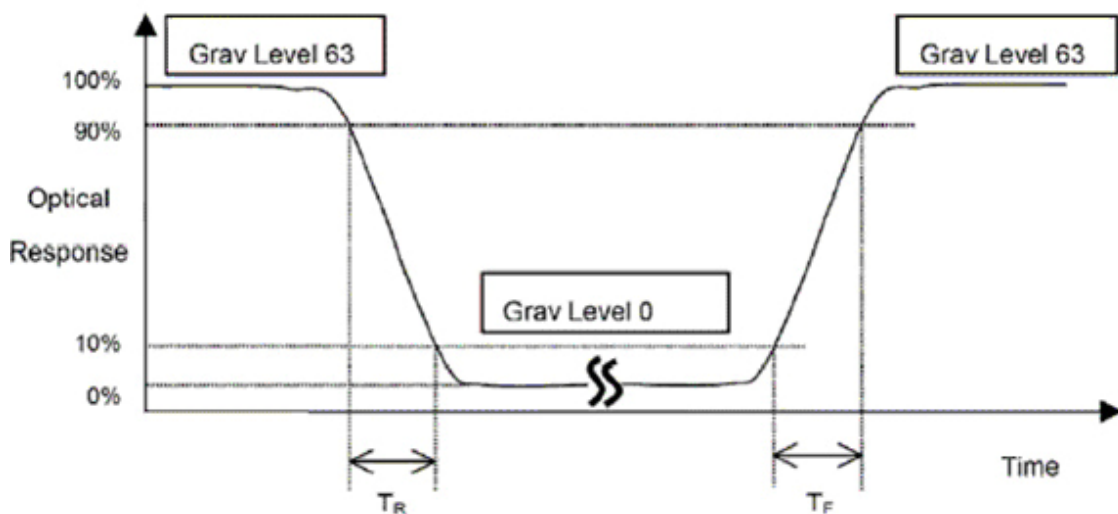

Note (3) Definition of viewing Angle:

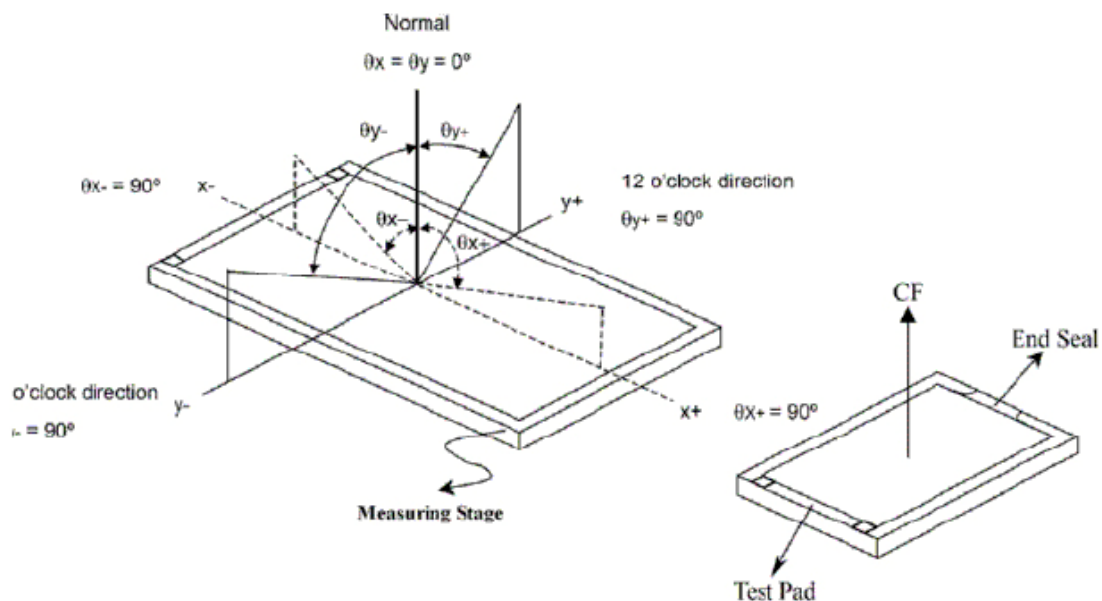

*** The above "Viewing Angle" is the measuring position with Largest Contrast Ratio; not for good image quality. View Direction for good image quality is 6 O'clock. Module maker can increase the "Viewing Angle" by applying Wide View Film.

MODEL NO ELT240320ATP

Note (4) Measurement Set-Up:

The LCD module should be stabilized at a given temperature for 20 minutes to avoid abrupt temperature change during measuring. In order to stabilize the luminance, the measurement should be executed after lighting Backlight for 20 minutes in a windless room.

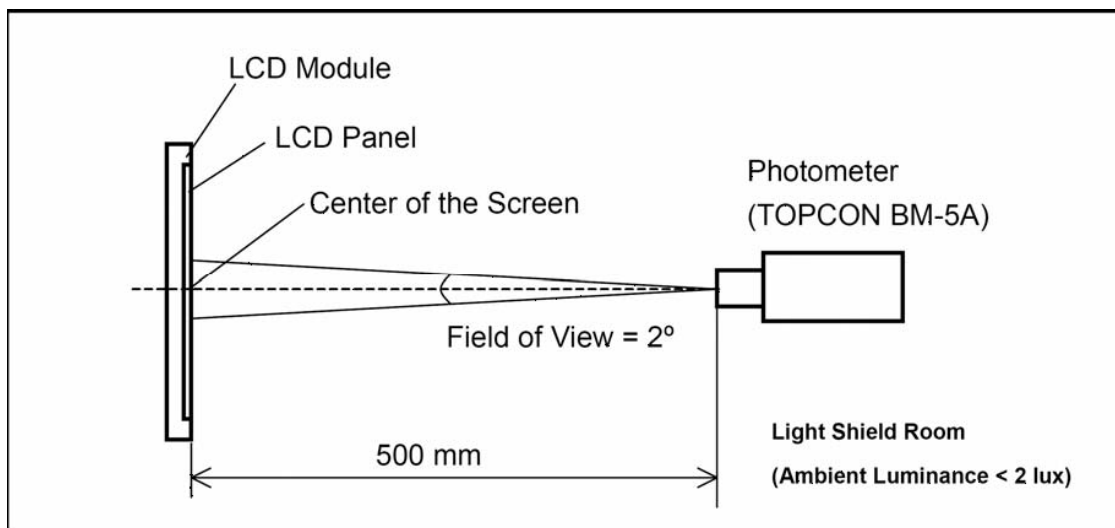

Note(5) Horizontal Dimension

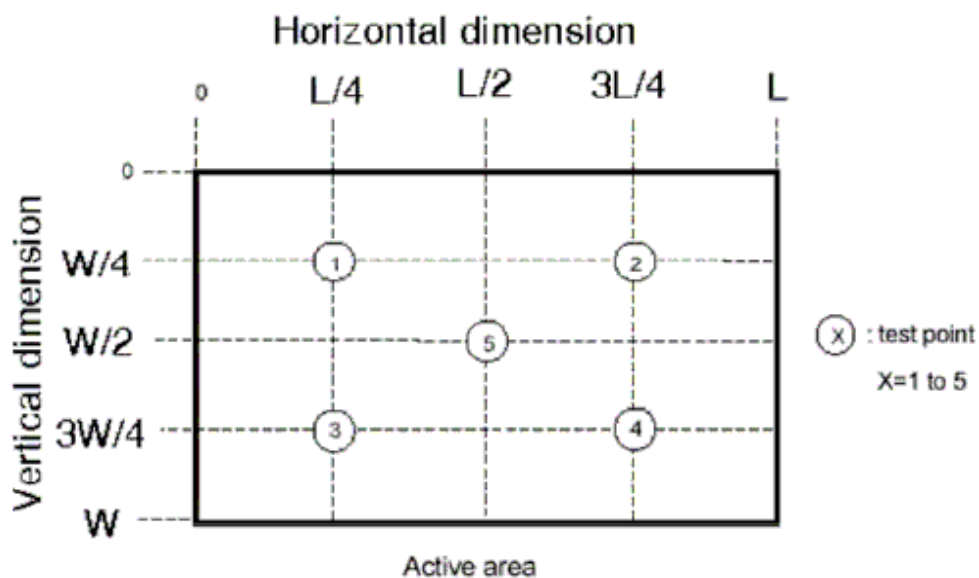

MODEL NO ELT240320ATP

7. Reliability Test Items

No.	Test Item	Test Condition	Check Time
1	High temp storage	T= 80°C	240 hrs
2	Low temp storage	T= -30°C	240 hrs
3	High temp operation	T= 70°C	240 hrs
4	Low temp operation	T= -20°C	240 hrs
5	High temp & high humidity	T=60°C H=90%	240 hrs

Reliability Test Criteria:

Display function should be no change under normal operating condition.

8. Package (TBD)

Please contact for more information.

9. Handling Precautions

9.1 Safety

The liquid crystal in the LCD is poisonous. Keep away from your mouth and eyes. If the liquid crystal contacts with your skin, mouse or clothes, use soap to wash it off immediately.

9.2 Handling

- i.** The LCD panel is made by thin glass. Prevent the panel from mechanical shock or putting excessive force on its surface.
- ii.** The polarizer attached on the display is very easy to be damaged, handle it with special attention.
- iii.** To avoid contamination on the display surface, do not touch the display surface with bare hands.
- iv.** The transparent electrodes may be disconnected if you use the LCD panel under dew-condensing environment.
- v.** The characteristics of the semiconductor devices may be affected when they are exposed to light, possibly resulting in malfunctioning of the ICs. To prevent such malfunctioning of the ICs, make sure the application and the mounting of the panel are designed so that the IC is not exposed to light.

9.3 Static Electricity

Ground soldering iron tips, tools and testers when you operate. Also ground your body when handling the products and store the products in an anti-electrostatic container.

9.4 Storage

Store the products in a dark place where the temperature is within the range of 25 ± 10 and with low humidity (65%RH or less). Do not store the LCD product in an atmosphere containing organic solvents or corrosive gases.

9.5 Cleaning

Do not wipe the polarizer with dry cloth, as it might cause scratching. Wipe the polarizer with a soft cloth soaked with petroleum IPA. Other chemical might damage the panel.

MODEL NO ELT240320ATP

LCD is easy to be damaged.
Please avoid the damaging and be careful for handling as below

