

CUSTOMER : _____.

DATE : FEB 28, 2014 .

REV : REV. 1.0 .

PRODUCT FAMILY DATA SHEET



3535 3W Ceramic PKG (H35C0)

MODEL NAME : LEMWA33X70/75/80 Series (G1)



CONTENTS

1. Features	3
2. Applications	3
3. Outline Dimensions	3
4. Absolute Maximum Ratings	4
5. Electro-Optical Characteristics	4 ~ 5
6. Flux Characteristics and Order Code	6 ~ 7
7. Chromaticity Bins	8 ~ 10
8. Typical Characteristic Curves	11 ~ 19
9. Reliability Test Items and Conditions	20
10. Packing and Labeling of Products	21 ~ 25
11. Cautions on Use	26 ~ 29
Appendix	30

1. Features

- Lighting Color : White
- Ceramic Type LED Package : 3.4×3.4×2.09 mm (L×W×H)
- Viewing Angle : 115°
- Chip Material : InGaN
- Soldering Method : Reflow Soldering
- ESD Withstand Voltage : Up to 2kV According to JESD22-A 114
- UL-recognized Component (E356829)
- RoHS Compliant

2. Applications

- Interior and Exterior Illumination

3. Outline Dimensions

(Unit : mm)

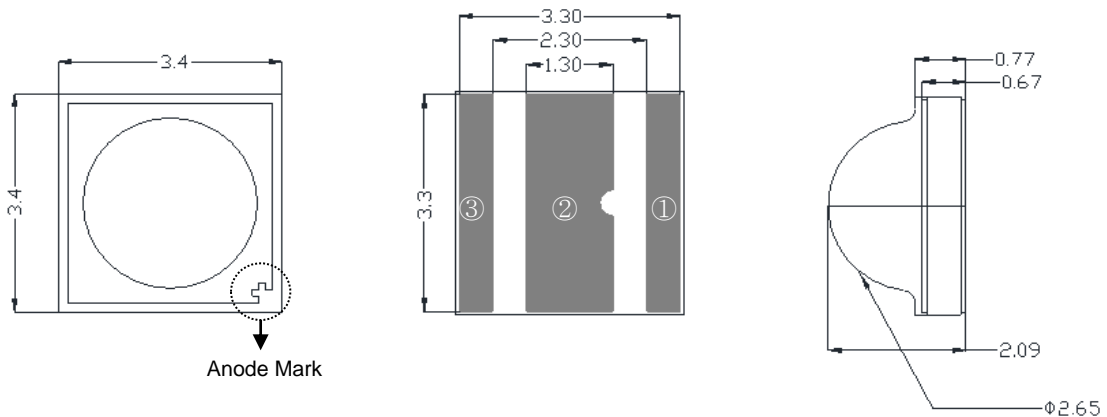

Recommended Soldering Pattern (for Reflow Soldering)

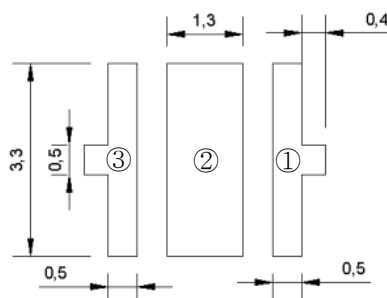
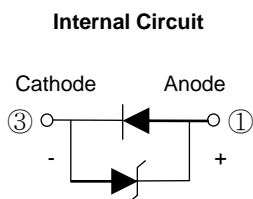

Pad Configuration

- ① Anode Pad
- ② Thermal Pad
- ③ Cathode Pad

※ The thermal pad is electrically isolated from the cathode and anode pads.

▪ Tolerance unless otherwise mentioned are ± 0.1 mm

4. Absolute Maximum Ratings

(Ta = 25°C)

Item	Symbol	Rating	Unit
Forward Current	If	1500	mA
Operating Temperature	Topr	-40 ~ +85	°C
Storage Temperature	Tstg	-40 ~ +100	°C
Junction Temperature	Tj	150	°C
Soldering Temperature	JEDEC-J-STD-020D		
ESD Classification	Class 2 (JESD22-A114)		

※ Operating the LED beyond the listed maximum ratings may affect device reliability and cause permanent damage.

These or any other conditions beyond those indicated under recommended operating conditions are not implied.

The exposure to the absolute maximum rated conditions may affect device reliability.

※ The LEDs are not designed to be driven in reverse bias.

5. Electro - Optical Characteristics

(Ta = 25°C, If = 350mA)

Item	Symbol	CCT	Min.	Typ.	Max.	Unit
Luminous Flux	Φ_v	6500 (F)	130 (122)	152 (146)	164 (156)	lm
		5700 (G)	130 (122)	152 (146)	164 (156)	
		5000 (H)	130 (122)	152 (144)	164 (156)	
		4000 (J)	130 (122)	145 (136)	156 (148)	
		3500 (K)	122	129	148	
		3000 (L)	107	122	139	
		2700 (M)	107	122	139	
Forward Voltage	Vf	All	2.90	2.95	3.20	V
Color	Cx / Cy	All	Refer to 'Chromaticity Bins'			-
Viewing Angle	2 Θ 1/2	All	-	115	-	deg
Color Rendering Index (Ra)	-	F, G, H	70	-	75	-
		J	70 / 80	-	-	
		K, L, M	80	-	-	
Thermal Resistance, Junction to Solder Point	Rth j-s	All	-	6	-	°C/W
Typical Temperature Coefficient of Forward Voltage ^{*1)}	$\Delta V_f / \Delta T_j$	All	-1	-	-4	mV/°C

※ These values are measured by the LG Innotek optical spectrum analyzer within the following tolerances.

Luminous Flux (Φ_v) : $\pm 7\%$, Forward Voltage (Vf) : $\pm 0.1V$, Color Value : ± 0.005 , CRI Value : ± 2 ,

※ The parentheses of 6500K, 5700K and 5000K are CRI 75 models, 4000K is CRI 80 model.

5. Electro - Optical Characteristics

CCT	CRI	If (mA)	Vf (V)	Power (W)	Φ_v (lm)	lm/W
6500K (F)	70	350	2.95	1.033	152	147
		700	3.12	2.184	274	125
		1000	3.27	3.270	367	112
		1500	3.54	5.310	500	94
5700K (G)	70	350	2.95	1.033	152	147
		700	3.12	2.184	274	125
		1000	3.27	3.270	367	112
		1500	3.54	5.310	500	94
5000K (H)	70	350	2.95	1.033	152	147
		700	3.12	2.184	274	125
		1000	3.27	3.270	367	112
		1500	3.54	5.310	500	94
6500K (F)	75	350	2.95	1.033	146	141
		700	3.12	2.184	263	120
		1000	3.27	3.270	352	108
		1500	3.54	5.310	480	90
5700K (G)	75	350	2.95	1.033	146	141
		700	3.12	2.184	263	120
		1000	3.27	3.270	352	108
		1500	3.54	5.310	480	90
5000K (H)	75	350	2.95	1.033	144	139
		700	3.12	2.184	259	119
		1000	3.27	3.270	347	106
		1500	3.54	5.310	474	89
4000K (J)	70	350	2.95	1.033	145	140
		700	3.12	2.184	261	120
		1000	3.27	3.270	350	107
		1500	3.54	5.310	477	90
	80	350	2.95	1.033	136	132
		700	3.12	2.184	245	112
		1000	3.27	3.270	328	100
		1500	3.54	5.310	447	84

※ Φ_v values are for representative references only.

5. Electro - Optical Characteristics

CCT	CRI	If (mA)	Vf (V)	Power (W)	Φ_v (lm)	lm/W
3500K (K)	80	350	2.95	1.033	129	125
		700	3.12	2.184	232	106
		1000	3.27	3.270	311	95
		1500	3.54	5.310	424	80
3000K (L)	80	350	2.95	1.033	122	118
		700	3.12	2.184	220	101
		1000	3.27	3.270	294	90
		1500	3.54	5.310	401	76
2700K (M)	80	350	2.95	1.033	122	118
		700	3.12	2.184	220	101
		1000	3.27	3.270	294	90
		1500	3.54	5.310	401	76

※ Φ_v values are for representative references only.

6. Flux Characteristics and Order Code

Color	CRI	CCT	Vf @ 350mA [V]	Luminous Flux [lm] @ 350mA			Order Code
				Bin Code	Min.	Max.	
Cool	70	6500 (F)		0	130	164	LEMWA33X70FW10xA
			2.8 ~ 2.9 (9)	X5 (5)	130	139	LEMWA33X70FW15xA
			2.9 ~ 3.0 (0)	X6 (6)	139	148	LEMWA33X70FW16xA
			3.0 ~ 3.1 (1)	X7 (7)	148	156	LEMWA33X70FW17xA
			3.1 ~ 3.2 (2)	X8 (8)	156	164	LEMWA33X70FW18xA
Cool	70	5700 (G)		0	130	164	LEMWA33X70GW10xA
			2.8 ~ 2.9 (9)	X5 (5)	130	139	LEMWA33X70GW15xA
			2.9 ~ 3.0 (0)	X6 (6)	139	148	LEMWA33X70GW16xA
			3.0 ~ 3.1 (1)	X7 (7)	148	156	LEMWA33X70GW17xA
			3.1 ~ 3.2 (2)	X8 (8)	156	164	LEMWA33X70GW18xA
Cool	70	5000 (H)		0	130	164	LEMWA33X70HW10xA
			2.8 ~ 2.9 (9)	X5 (5)	130	139	LEMWA33X70HW15xA
			2.9 ~ 3.0 (0)	X6 (6)	139	148	LEMWA33X70HW16xA
			3.0 ~ 3.1 (1)	X7 (7)	148	156	LEMWA33X70HW17xA
			3.1 ~ 3.2 (2)	X8 (8)	156	164	LEMWA33X70HW18xA
Cool	75	6500 (F)		0	122	156	LEMWA33X75FW10xA
			2.8 ~ 2.9 (9)	X4 (4)	122	130	LEMWA33X75FW14xA
			2.9 ~ 3.0 (0)	X5 (5)	130	139	LEMWA33X75FW15xA
			3.0 ~ 3.1 (1)	X6 (6)	139	148	LEMWA33X75FW16xA
			3.1 ~ 3.2 (2)	X7 (7)	148	156	LEMWA33X75FW17xA
Cool	75	5700 (G)		0	122	156	LEMWA33X75GW10xA
			2.8 ~ 2.9 (9)	X4 (4)	122	130	LEMWA33X75GW14xA
			2.9 ~ 3.0 (0)	X5 (5)	130	139	LEMWA33X75GW15xA
			3.0 ~ 3.1 (1)	X6 (6)	139	148	LEMWA33X75GW16xA
			3.1 ~ 3.2 (2)	X7 (7)	148	156	LEMWA33X75GW17xA
Cool	75	5000 (H)		0	122	156	LEMWA33X75HW10xA
			2.8 ~ 2.9 (9)	X4 (4)	122	130	LEMWA33X75HW14xA
			2.9 ~ 3.0 (0)	X5 (5)	130	139	LEMWA33X75HW15xA
			3.0 ~ 3.1 (1)	X6 (6)	139	148	LEMWA33X75HW16xA
			3.1 ~ 3.2 (2)	X7 (7)	148	156	LEMWA33X75HW17xA

6. Flux Characteristics and Order Code (Continued)

Color	CRI	CCT	Vf @ 350mA [V]	Luminous Flux [lm] @ 350mA			Order Code
				Bin Code	Min.	Max.	
Neutral	70	4000 (J)	2.8 ~ 2.9 (9) 2.9 ~ 3.0 (0) 3.0 ~ 3.1 (1) 3.1 ~ 3.2 (2)	0	130	156	LEMWA33X70JW30xA
				X5 (5)	130	139	LEMWA33X70JW35xA
				X6 (6)	139	148	LEMWA33X70JW36xA
				X7 (7)	148	156	LEMWA33X70JW37xA
Neutral	80	4000 (J)	2.8 ~ 2.9 (9) 2.9 ~ 3.0 (0) 3.0 ~ 3.1 (1) 3.1 ~ 3.2 (2)	0	122	148	LEMWA33X80JW30xA
				X4 (4)	122	130	LEMWA33X80JW34xA
				X5 (5)	130	139	LEMWA33X80JW35xA
				X6 (6)	139	148	LEMWA33X80JW36xA
Warm	80	3500 (K)	2.8 ~ 2.9 (9) 2.9 ~ 3.0 (0) 3.0 ~ 3.1 (1) 3.1 ~ 3.2 (2)	0	114	148	LEMWA33X80KW30xA
				X3 (3)	114	122	LEMWA33X80KW33xA
				X4 (4)	122	130	LEMWA33X80KW34xA
				X5 (5)	130	139	LEMWA33X80KW35xA
				X6 (6)	139	148	LEMWA33X80KW36xA
Warm	80	3000 (L)	2.8 ~ 2.9 (9) 2.9 ~ 3.0 (0) 3.0 ~ 3.1 (1) 3.1 ~ 3.2 (2)	0	107	139	LEMWA33X80LW30xA
				X2 (2)	107	114	LEMWA33X80LW32xA
				X3 (3)	114	122	LEMWA33X80LW33xA
				X4 (4)	122	130	LEMWA33X80LW34xA
				X5 (5)	130	139	LEMWA33X80LW35xA
Warm	80	2700 (M)	2.8 ~ 2.9 (9) 2.9 ~ 3.0 (0) 3.0 ~ 3.1 (1) 3.1 ~ 3.2 (2)	0	107	139	LEMWA33X80MW30xA
				X2 (2)	107	114	LEMWA33X80MW32xA
				X3 (3)	114	122	LEMWA33X80MW33xA
				X4 (4)	122	130	LEMWA33X80MW34xA
				X5 (5)	130	139	LEMWA33X80MW35xA

7. Chromaticity Bins

LG Innotek complies with the ANSI C78.377A standard for its chromaticity bin structure. For each ANSI quadrangle for the CCT range of 4500K to 6500K, LG Innotek provides 4 micro bins.

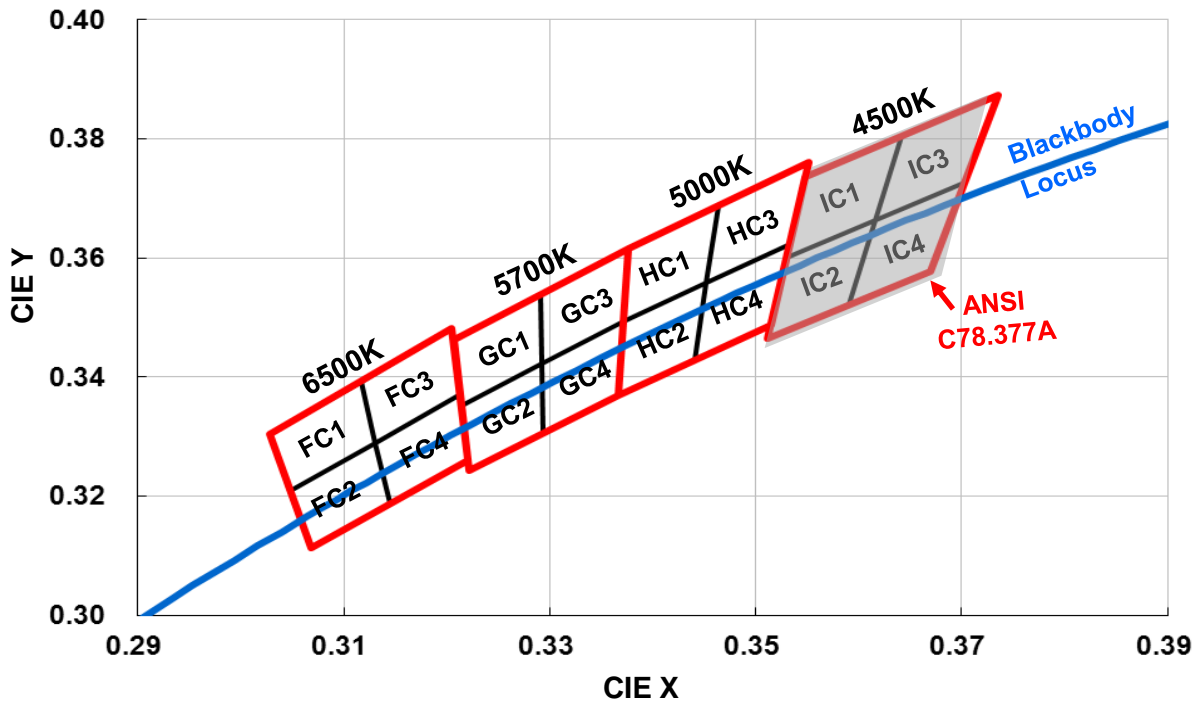

Bin	CIE X	CIE Y	Bin	CIE X	CIE Y	Bin	CIE X	CIE Y	Bin	CIE X	CIE Y
FC1	0.3028	0.3304	GC1	0.3207	0.3462	HC1	0.3376	0.3616	IC1	0.3548	0.3736
	0.3117	0.3393		0.3292	0.3539		0.3464	0.3688		0.3642	0.3805
	0.3131	0.3290		0.3293	0.3423		0.3452	0.3558		0.3617	0.3663
	0.3048	0.3209		0.3215	0.3353		0.3371	0.3493		0.3530	0.3601
FC2	0.3048	0.3209	GC2	0.3215	0.3353	HC2	0.3371	0.3493	IC2	0.3530	0.3601
	0.3131	0.3290		0.3293	0.3423		0.3452	0.3558		0.3617	0.3663
	0.3145	0.3187		0.3294	0.3306		0.3441	0.3428		0.3591	0.3522
	0.3068	0.3113		0.3222	0.3243		0.3366	0.3369		0.3512	0.3465
FC3	0.3117	0.3393	GC3	0.3292	0.3539	HC3	0.3464	0.3688	IC3	0.3642	0.3805
	0.3205	0.3481		0.3376	0.3616		0.3551	0.3760		0.3736	0.3874
	0.3213	0.3371		0.3371	0.3493		0.3533	0.3624		0.3703	0.3726
	0.3131	0.3290		0.3293	0.3423		0.3452	0.3558		0.3617	0.3663
FC4	0.3131	0.3290	GC4	0.3293	0.3423	HC4	0.3452	0.3558	IC4	0.3617	0.3663
	0.3213	0.3371		0.3371	0.3493		0.3533	0.3624		0.3703	0.3726
	0.3221	0.3261		0.3366	0.3369		0.3515	0.3487		0.3670	0.3578
	0.3145	0.3187		0.3294	0.3306		0.3441	0.3428		0.3591	0.3522

7. Chromaticity Bins (Continued)

LG Innotek complies with the ANSI C78.377A standard for its chromaticity bin structure. For each ANSI quadrangle for the CCT range of 2700K to 4000K, LG Innotek provides 16 micro bins.

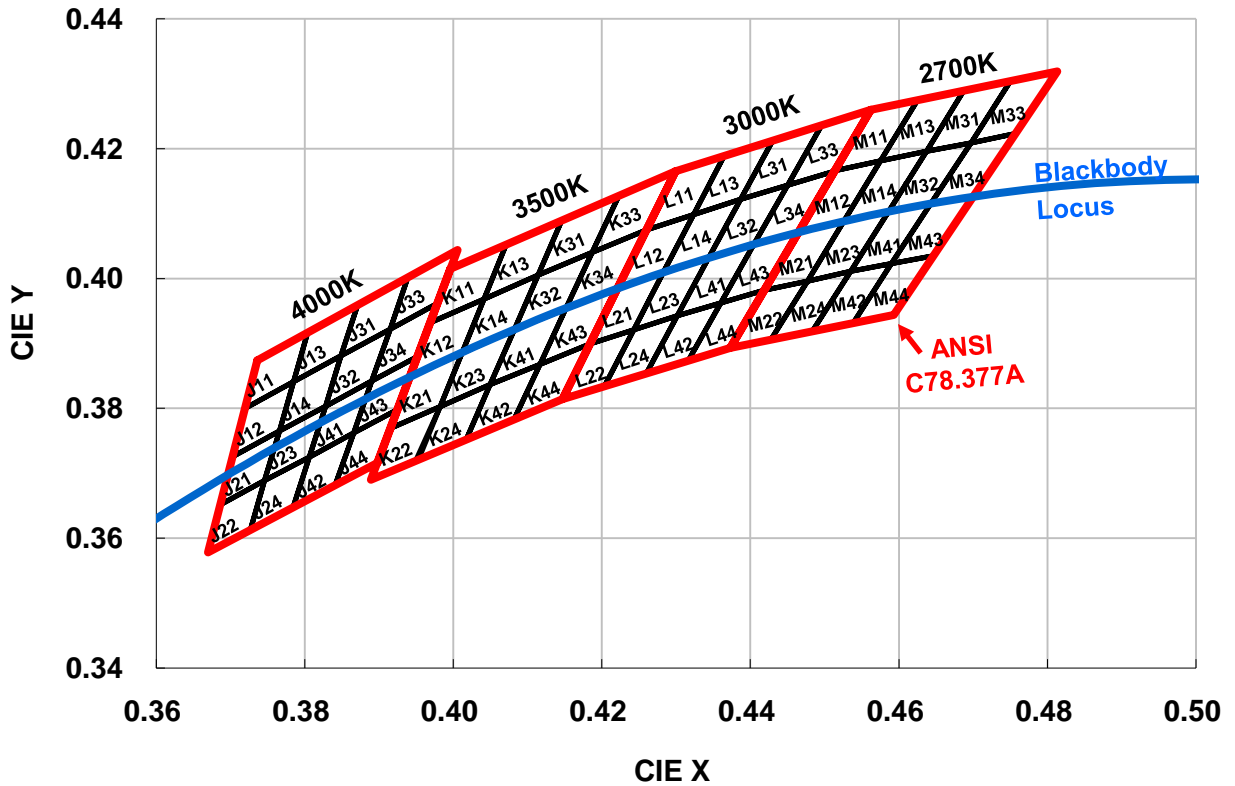

Bin	CIE X	CIE Y	Bin	CIE X	CIE Y	Bin	CIE X	CIE Y	Bin	CIE X	CIE Y
J11	0.3736	0.3874	K11	0.3996	0.4015	L11	0.4299	0.4165	M11	0.4562	0.4260
	0.3804	0.3917		0.4071	0.4052		0.4364	0.4189		0.4625	0.4275
	0.3785	0.3841		0.4041	0.3969		0.4323	0.4098		0.4575	0.4181
	0.3720	0.3800		0.3969	0.3932		0.4260	0.4075		0.4513	0.4166
J12	0.3720	0.3800	K12	0.3969	0.3932	L12	0.4260	0.4075	M12	0.4513	0.4166
	0.3785	0.3841		0.4041	0.3969		0.4323	0.4098		0.4575	0.4181
	0.3766	0.3765		0.4012	0.3885		0.4282	0.4008		0.4525	0.4087
	0.3703	0.3726		0.3941	0.3848		0.4221	0.3984		0.4465	0.4071
J13	0.3804	0.3917	K13	0.4071	0.4052	L13	0.4364	0.4189	M13	0.4625	0.4275
	0.3871	0.3959		0.4146	0.4089		0.4430	0.4212		0.4687	0.4289
	0.3849	0.3881		0.4114	0.4005		0.4387	0.4122		0.4637	0.4196
	0.3785	0.3841		0.4041	0.3969		0.4323	0.4098		0.4575	0.4181
J14	0.3785	0.3841	K14	0.4041	0.3969	L14	0.4323	0.4098	M14	0.4575	0.4181
	0.3849	0.3881		0.4114	0.4005		0.4387	0.4122		0.4637	0.4196
	0.3828	0.3803		0.4082	0.3922		0.4344	0.4032		0.4586	0.4103
	0.3766	0.3765		0.4012	0.3885		0.4282	0.4008		0.4525	0.4087

7. Chromaticity Bins (Continued)

Bin	CIE X	CIE Y	Bin	CIE X	CIE Y	Bin	CIE X	CIE Y	Bin	CIE X	CIE Y
J21	0.3703	0.3726	K21	0.3941	0.3848	L21	0.4221	0.3984	M21	0.4465	0.4071
	0.3766	0.3765		0.4012	0.3885		0.4282	0.4008		0.4525	0.4087
	0.3746	0.3689		0.3982	0.3803		0.4243	0.3921		0.4477	0.3996
	0.3687	0.3652		0.3915	0.3769		0.4184	0.3899		0.4419	0.3982
J22	0.3687	0.3652	K22	0.3915	0.3769	L22	0.4184	0.3899	M22	0.4419	0.3982
	0.3746	0.3689		0.3982	0.3803		0.4243	0.3921		0.4477	0.3996
	0.3727	0.3613		0.3950	0.3721		0.4203	0.3834		0.4428	0.3906
	0.3670	0.3578		0.3889	0.3690		0.4147	0.3814		0.4373	0.3893
J23	0.3766	0.3765	K23	0.4012	0.3885	L23	0.4282	0.4008	M23	0.4525	0.4087
	0.3828	0.3803		0.4082	0.3922		0.4344	0.4032		0.4586	0.4103
	0.3806	0.3725		0.4050	0.3837		0.4302	0.3943		0.4535	0.4011
	0.3746	0.3689		0.3982	0.3803		0.4243	0.3921		0.4477	0.3996
J24	0.3746	0.3689	K24	0.3982	0.3803	L24	0.4243	0.3921	M24	0.4477	0.3996
	0.3806	0.3725		0.4050	0.3837		0.4302	0.3943		0.4535	0.4011
	0.3784	0.3647		0.4017	0.3752		0.4260	0.3853		0.4483	0.3918
	0.3727	0.3613		0.3953	0.3721		0.4203	0.3834		0.4428	0.3906
J31	0.3871	0.3959	K31	0.4146	0.4089	L31	0.4430	0.4212	M31	0.4687	0.4289
	0.3939	0.4002		0.4223	0.4127		0.4496	0.4236		0.4750	0.4304
	0.3915	0.3922		0.4187	0.4040		0.4450	0.4144		0.4697	0.4209
	0.3849	0.3881		0.4114	0.4005		0.4387	0.4122		0.4637	0.4196
J32	0.3849	0.3881	K32	0.4114	0.4005	L32	0.4387	0.4122	M32	0.4637	0.4196
	0.3915	0.3922		0.4187	0.4040		0.4450	0.4144		0.4697	0.4209
	0.3890	0.3842		0.4151	0.3953		0.4404	0.4052		0.4643	0.4115
	0.3828	0.3803		0.4082	0.3922		0.4344	0.4032		0.4586	0.4103
J33	0.3939	0.4002	K33	0.4223	0.4127	L33	0.4496	0.4236	M33	0.4750	0.4304
	0.4006	0.4044		0.4299	0.4165		0.4562	0.4260		0.4813	0.4319
	0.3979	0.3962		0.4260	0.4075		0.4513	0.4166		0.4756	0.4223
	0.3915	0.3922		0.4187	0.4040		0.4450	0.4144		0.4697	0.4209
J34	0.3915	0.3922	K34	0.4187	0.4040	L34	0.4450	0.4144	M34	0.4697	0.4209
	0.3979	0.3962		0.4260	0.4075		0.4513	0.4166		0.4756	0.4223
	0.3952	0.3880		0.4221	0.3984		0.4465	0.4071		0.4700	0.4126
	0.3890	0.3842		0.4151	0.3953		0.4404	0.4052		0.4643	0.4115
J41	0.3828	0.3803	K41	0.4082	0.3922	L41	0.4344	0.4032	M41	0.4586	0.4103
	0.3890	0.3842		0.4151	0.3953		0.4404	0.4052		0.4643	0.4115
	0.3866	0.3762		0.4117	0.3868		0.4360	0.3962		0.4590	0.4023
	0.3806	0.3725		0.4050	0.3837		0.4302	0.3943		0.4535	0.4011
J42	0.3806	0.3725	K42	0.4050	0.3837	L42	0.4302	0.3943	M42	0.4535	0.4011
	0.3866	0.3762		0.4117	0.3868		0.4360	0.3962		0.4590	0.4023
	0.3841	0.3682		0.4082	0.3783		0.4316	0.3873		0.4538	0.3931
	0.3784	0.3647		0.4017	0.3752		0.4260	0.3853		0.4483	0.3918
J43	0.3890	0.3842	K43	0.4151	0.3953	L43	0.4404	0.4052	M43	0.4643	0.4115
	0.3952	0.3880		0.4221	0.3984		0.4465	0.4071		0.4700	0.4126
	0.3925	0.3798		0.4184	0.3899		0.4419	0.3982		0.4646	0.4035
	0.3866	0.3762		0.4117	0.3868		0.4360	0.3962		0.4590	0.4023
J44	0.3866	0.3762	K44	0.4117	0.3868	L44	0.4360	0.3962	M44	0.4590	0.4023
	0.3925	0.3798		0.4184	0.3899		0.4419	0.3982		0.4646	0.4035
	0.3898	0.3716		0.4147	0.3814		0.4373	0.3893		0.4593	0.3944
	0.3841	0.3682		0.4082	0.3783		0.4316	0.3873		0.4538	0.3931

8. Typical Characteristic Curves

▪ Forward Current vs. Forward Voltage

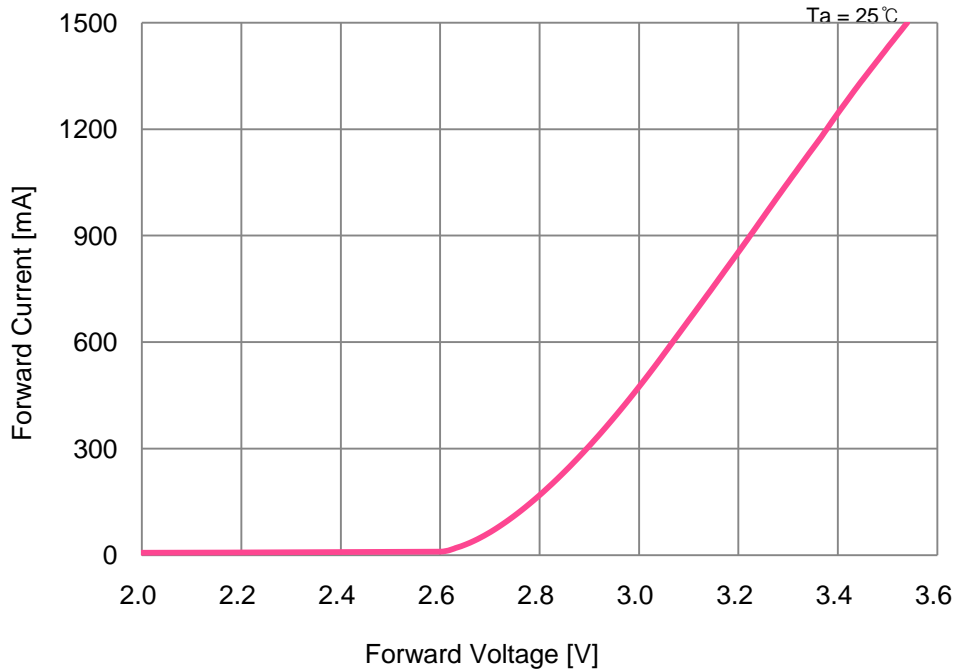

▪ Relative Luminous Flux vs. Forward Current

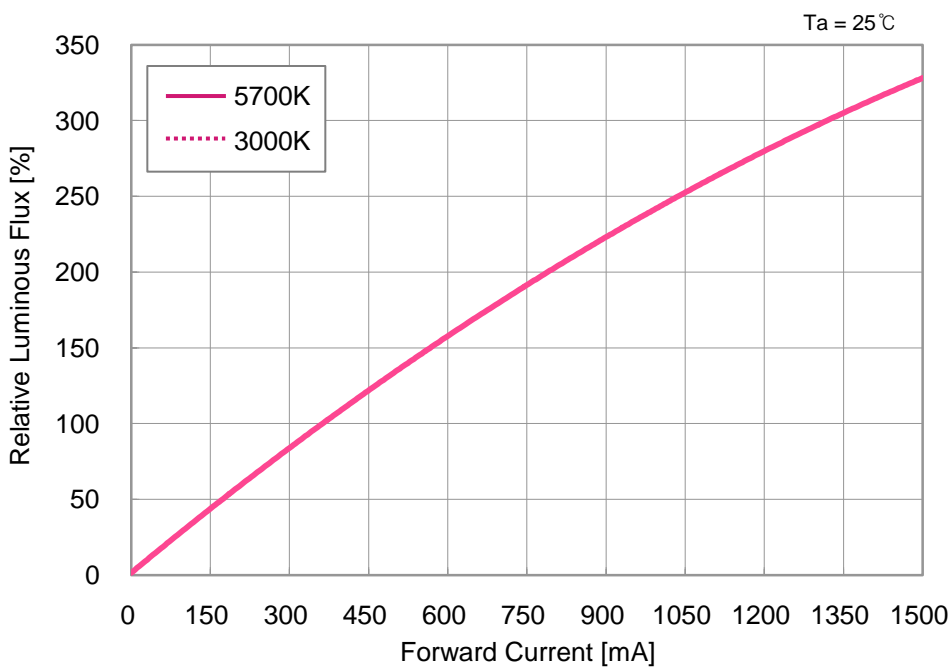

※ 5700K CCT data also applies to 5000K and 6500K CCTs and 3000K data also applies to 2700K, 3500K and 4000K CCTs.

8. Typical Characteristic Curves

- Spectrum

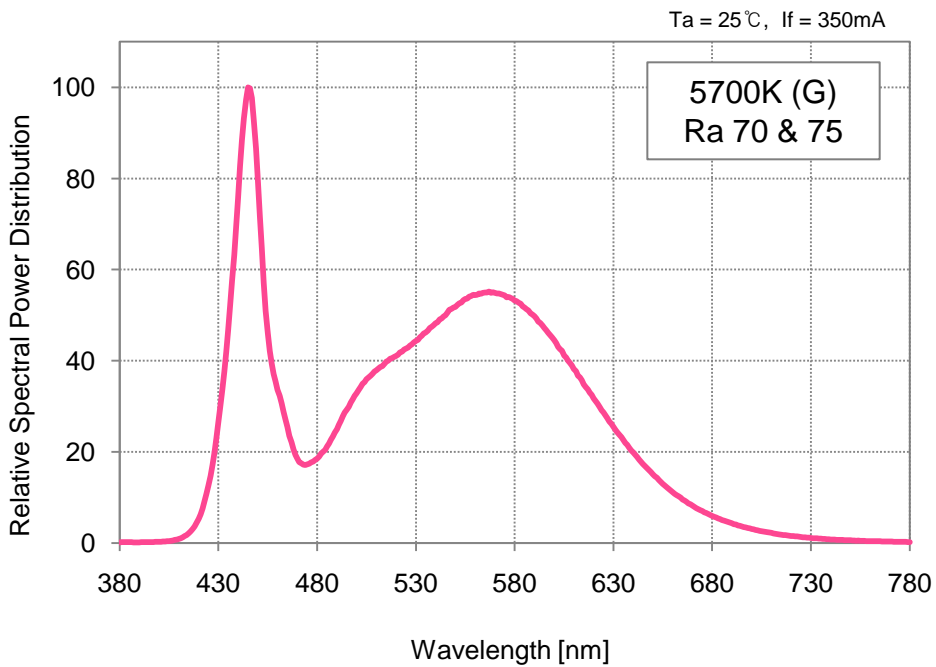
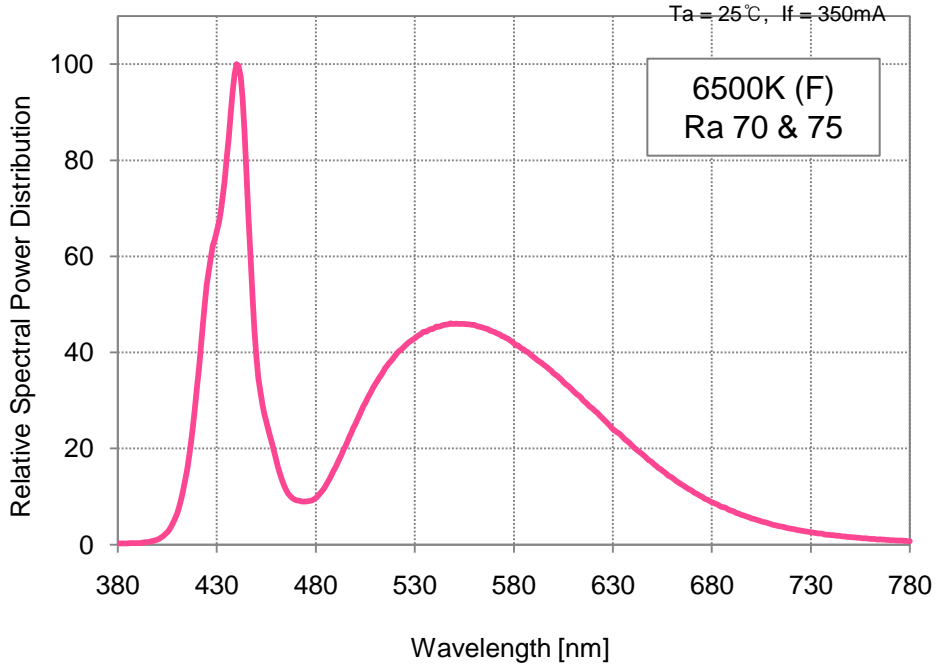

8. Typical Characteristic Curves

- Spectrum

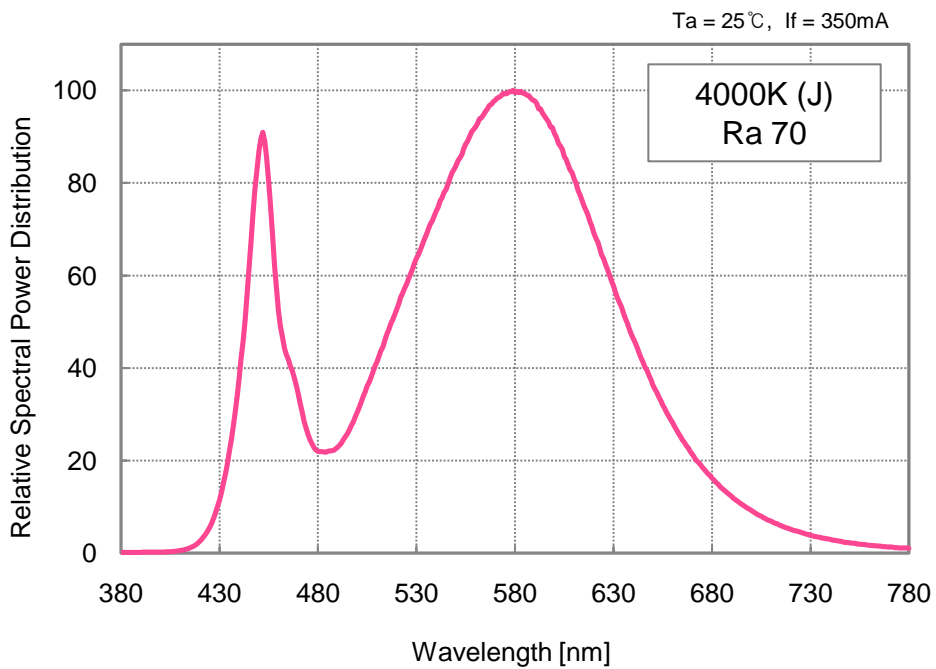
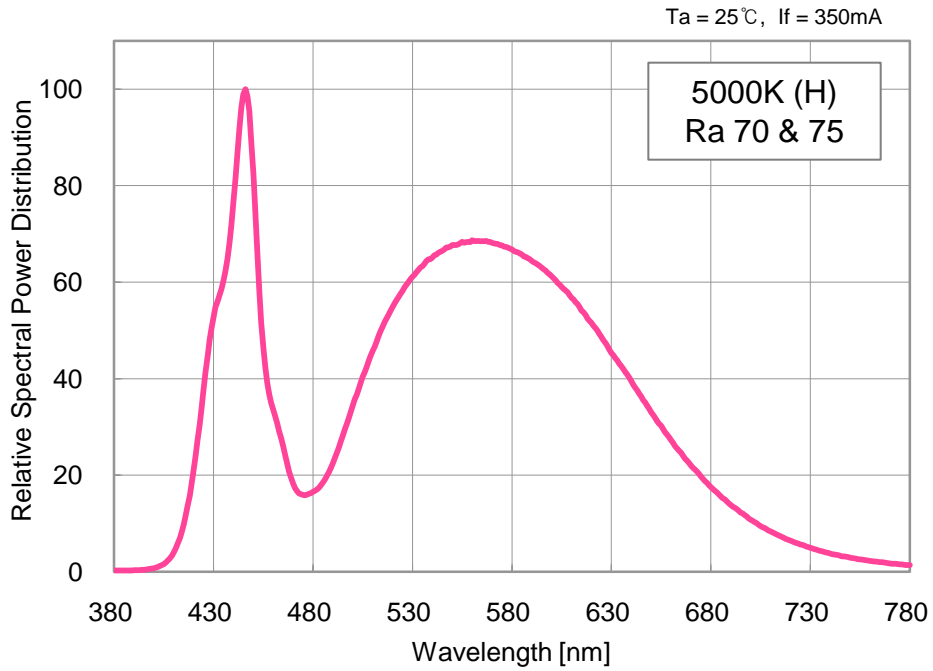

8. Typical Characteristic Curves

- Spectrum

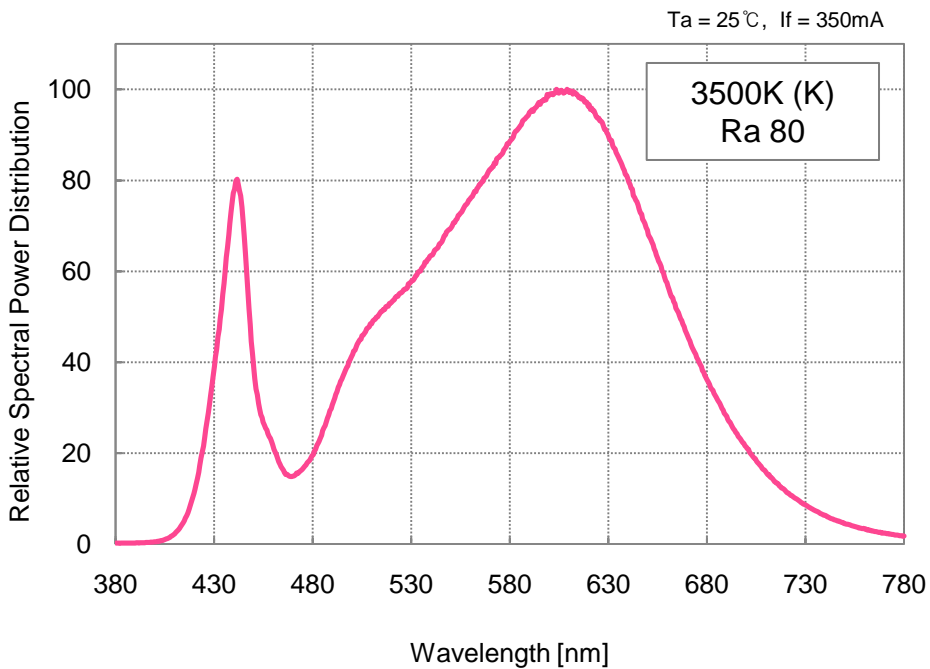
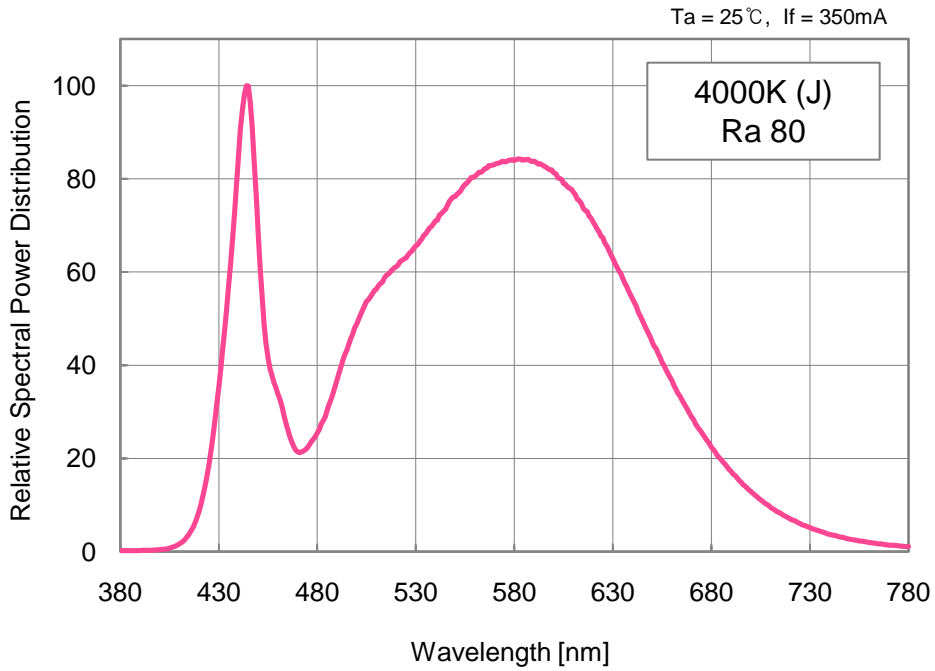

8. Typical Characteristic Curves

- Spectrum

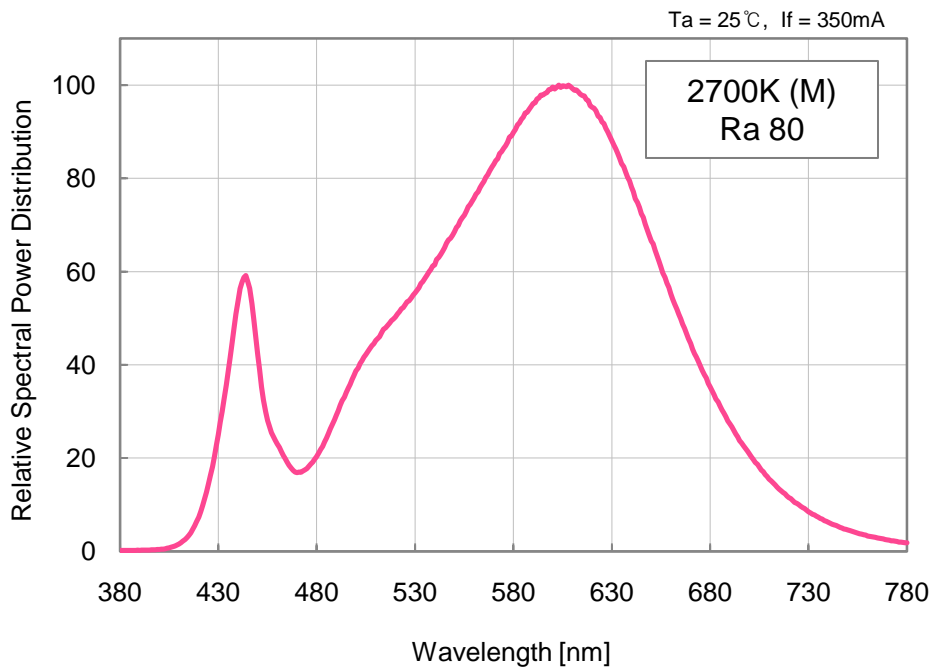
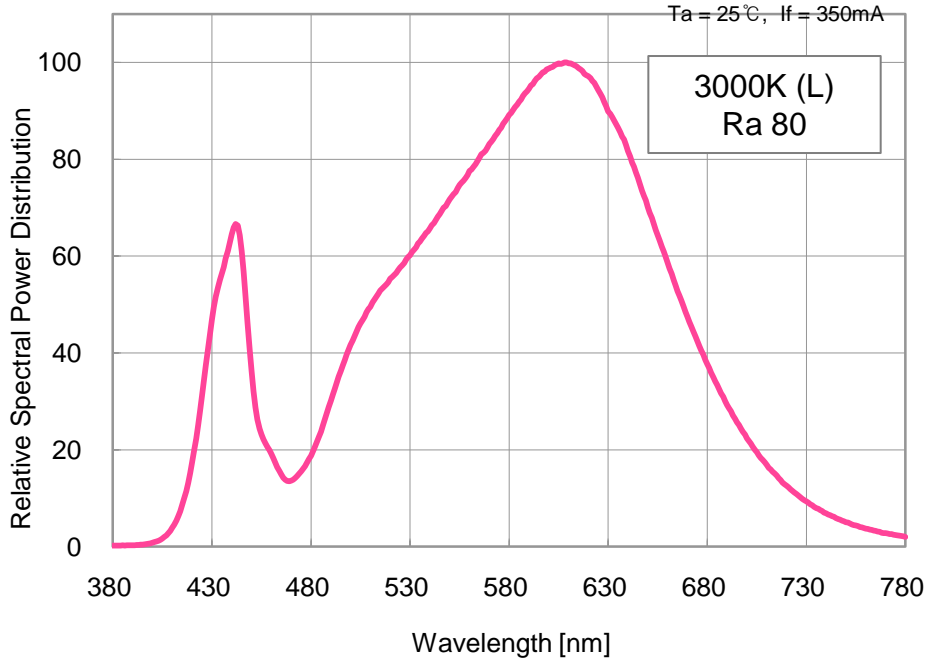

8. Typical Characteristic Curves

▪ Chromaticity Coordinate vs. Forward Current

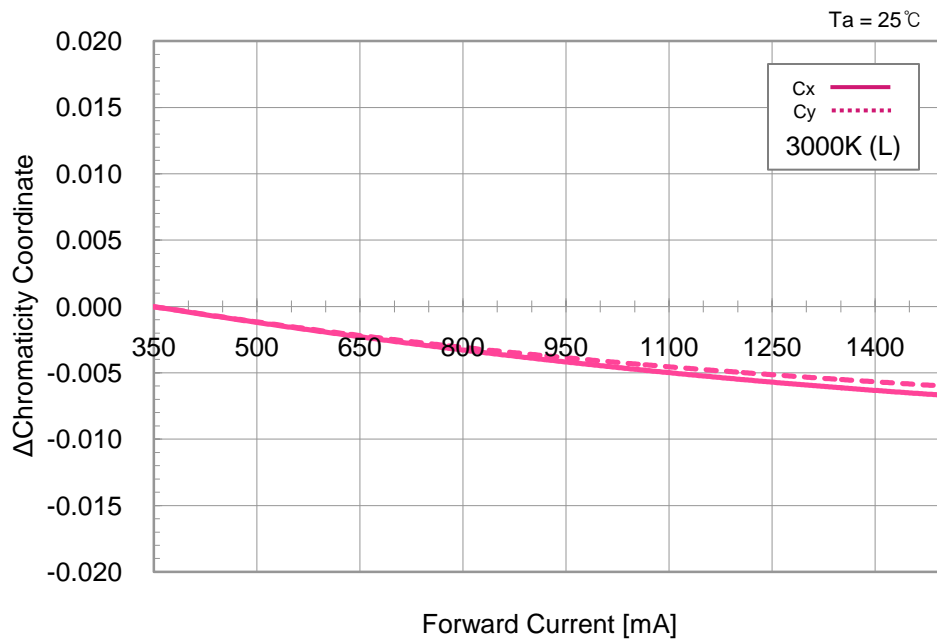
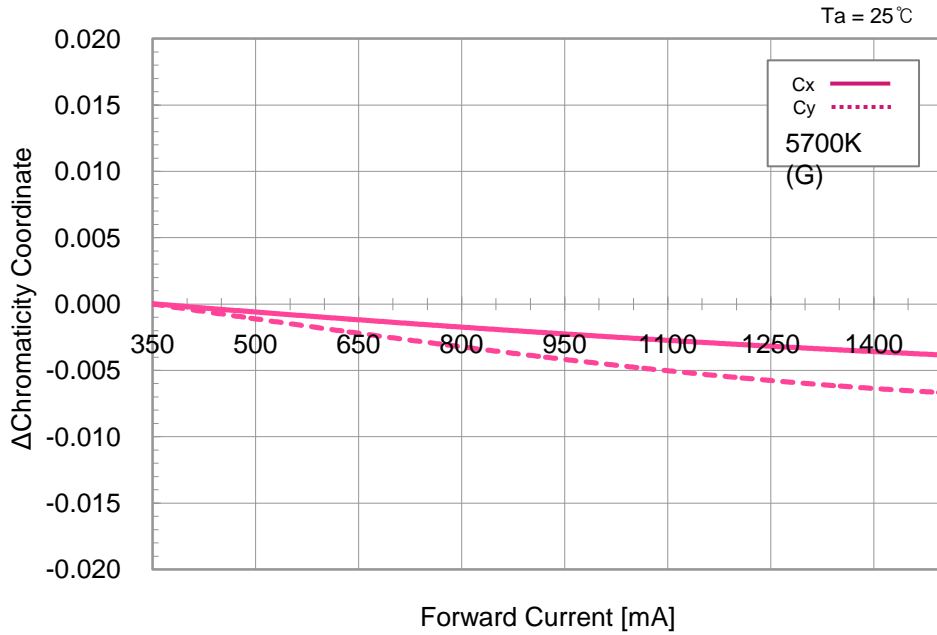

※ 5700K CCT data also applies to 5000K and 6500K CCTs and 3000K data also applies to 2700K, 3500K and 4000K CCTs.

8. Typical Characteristic Curves

▪ Radiation Characteristics

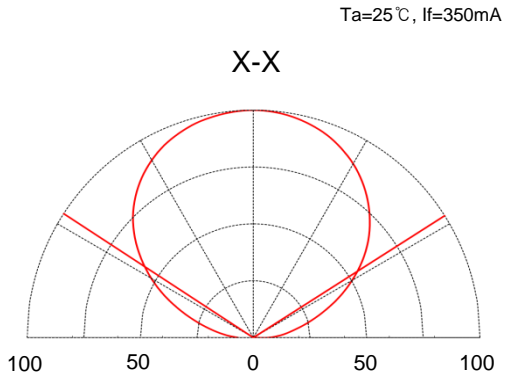

Cool

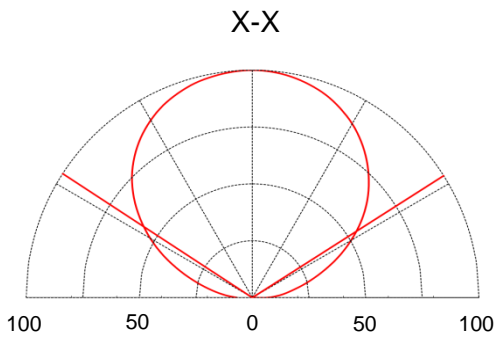
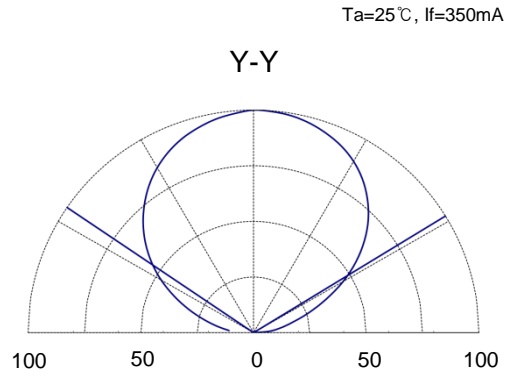

Warm

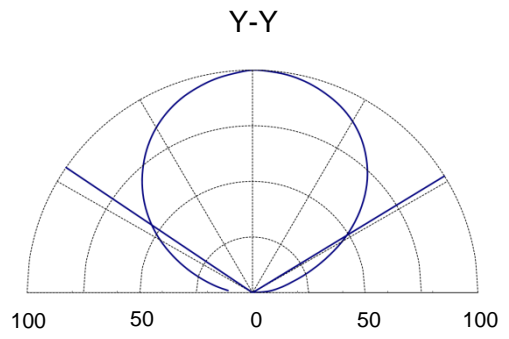

▪ Luminous Flux vs. Temperature

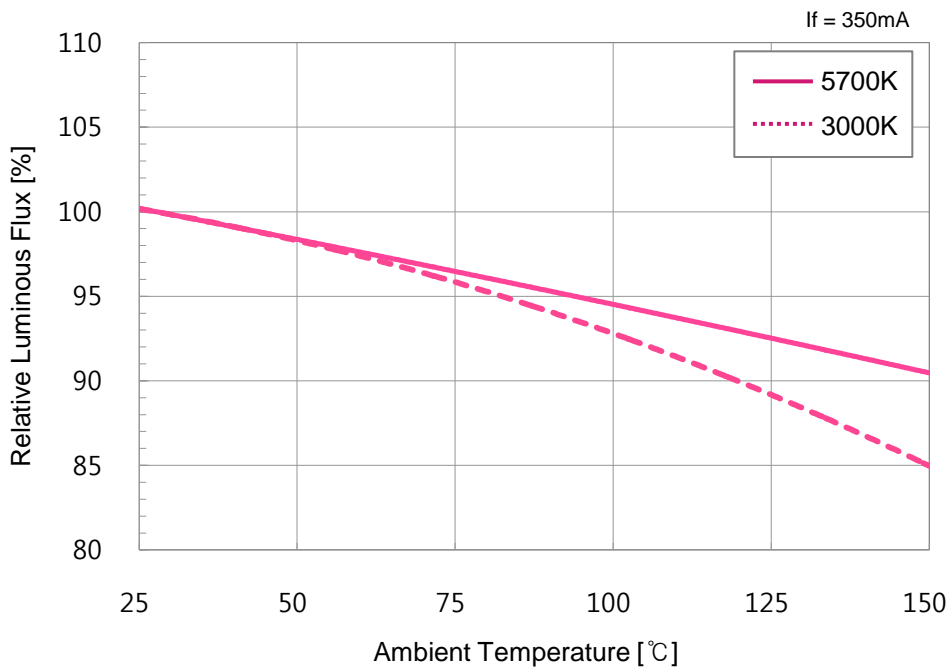

8. Typical Characteristic Curves

▪ Chromaticity Coordinate vs. Temperature

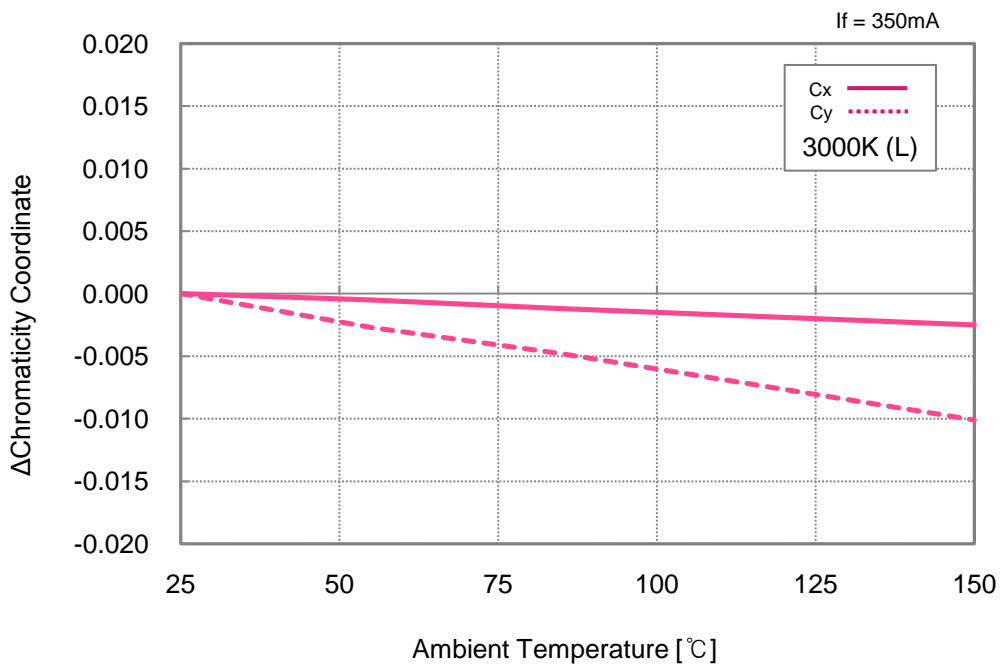
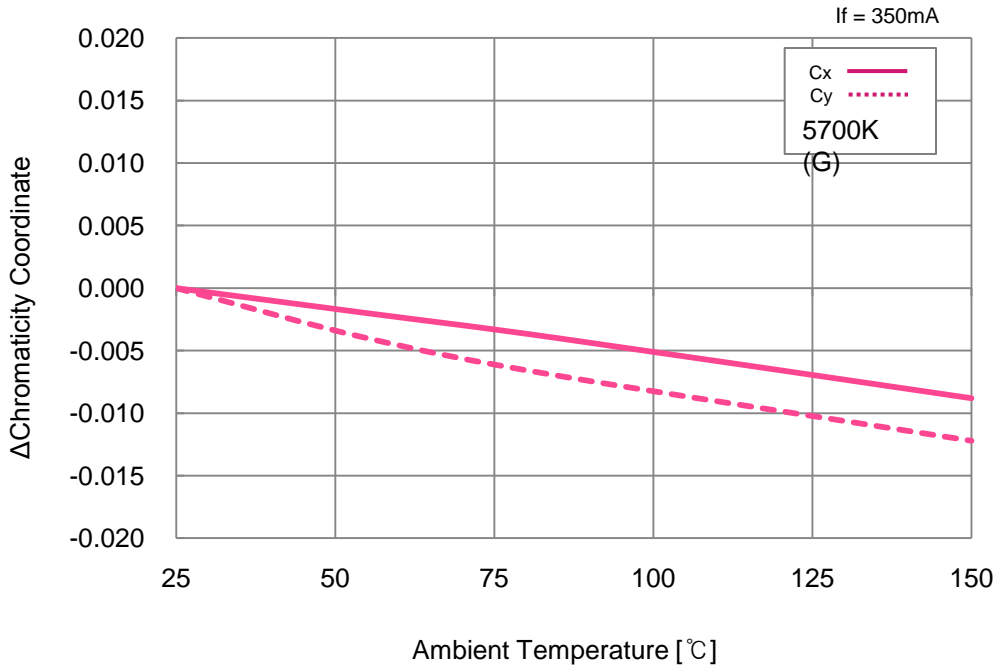

※ 5700K CCT data also applies to 5000K and 6500K CCTs and 3000K data also applies to 2700K, 3500K and 4000K CCTs.

8. Typical Characteristic Curves

▪ Forward Voltage vs. Temperature

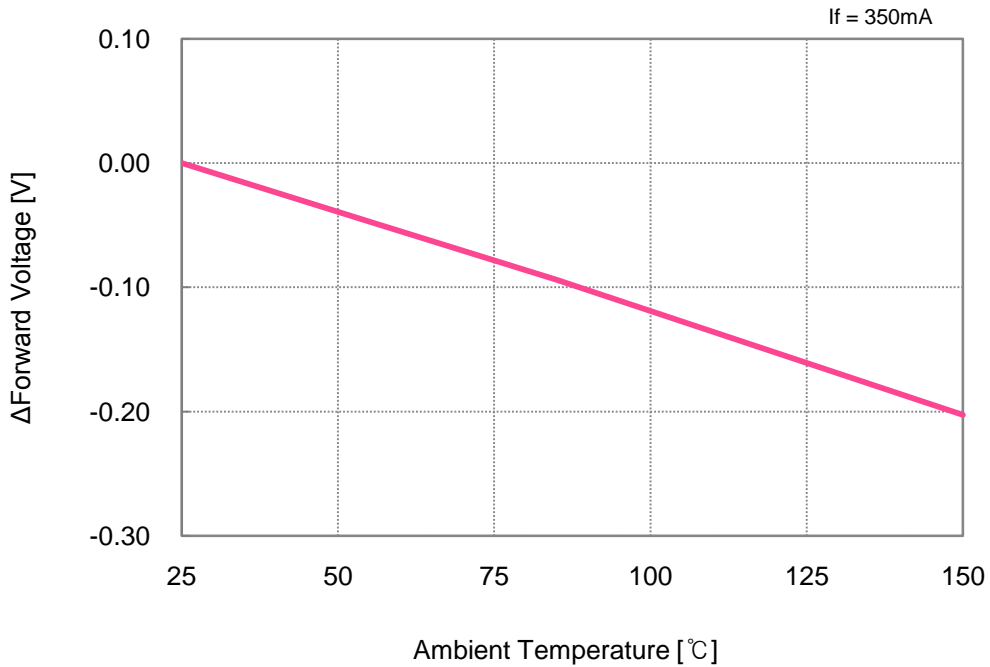

▪ Derating Curve

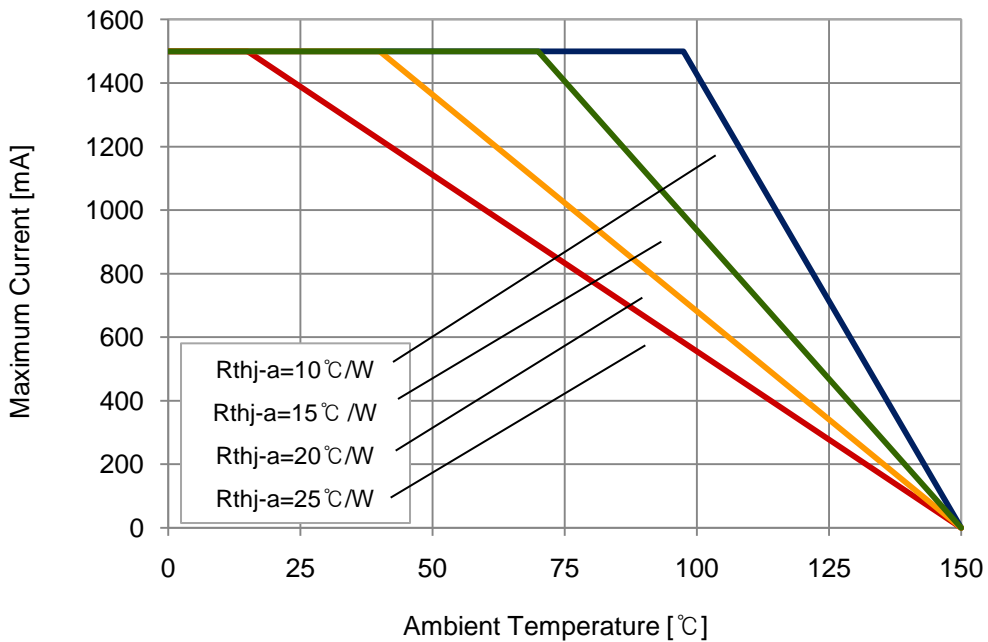

※ The ambient temperature values for each graph are obtained with LG Innotek equipment.

9. Reliability Test Items and Conditions

9-1. Failure Criteria

Items	Symbols	Test Conditions	Limits	
			Min.	Max.
Forward Voltage	V_f	$I_f = 350\text{mA}$	-	Initial Value $\times 1.3$
Luminous Flux	Φ_v	$I_f = 350\text{mA}$	Initial Value $\times 0.7$	-

9-2. Reliability Tests

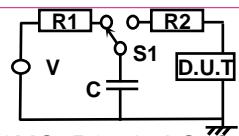
No	Items	Test Conditions	Test Hours / Cycles
1	Steady-State Operation	$T_a = 25^\circ\text{C}$, $I_f = 1,500$ [mA]	1,000 Hours
2	Steady-State Operation under High Temperature / High Humidity	$T_a = 85^\circ\text{C}$, 85% RH, $I_f = 1,000$ [mA]	1,000 Hours
3	Steady-State Operation under High Temperature	$T_a = 85^\circ\text{C}$, $I_f = 1,000$ [mA]	1,000 Hours
4	Steady-State Operation under Low Temperature	$T_a = -40^\circ\text{C}$, $I_f = 1,000$ [mA]	1,000 Hours
5	Storage under High Temperature	$T_a = 100^\circ\text{C}$	1,000 Hours
6	Storage under Low Temperature	$T_a = -40^\circ\text{C}$	1,000 Hours
7	Temperature Cycling	-40°C (30 min.) \sim 25°C (5 min.) \sim 100°C (30 min.) \sim 25°C (5 min.)	100 Cycles
8	Thermal Shock	100°C (15 min.) \sim 25°C (5 min.) \sim -40°C (15 min.)	100 Cycles
9	Resistance to Soldering Heat (Reflow Soldering)	$T_{\text{sld}} = 260^\circ\text{C}$, 10 sec./ 2 times (Pre Treat. 30°C , 70% RH, 168hr)	2 Times
10	Electrostatic Discharge Test Voltage 2kV (HBM)	 <p>$R1 : 10\text{M}\Omega$, $R2 : 1.5\text{k}\Omega$, $C : 100\text{pF}$</p>	3 Times
11	Vibration	100~2000~100Hz Sweep 4 min. 200m/s^2 , 3 direction, 4 cycles	48 Minutes

* All samples are tested using LG Innotek Standard Metal PCB (25x25x1.6 mm³ (L×W×H)) except MSL test .

* All samples must pass each test item and all test items must be satisfied.

10. Packing and Labeling of Product

10-1. Taping Outline Dimensions

Reel

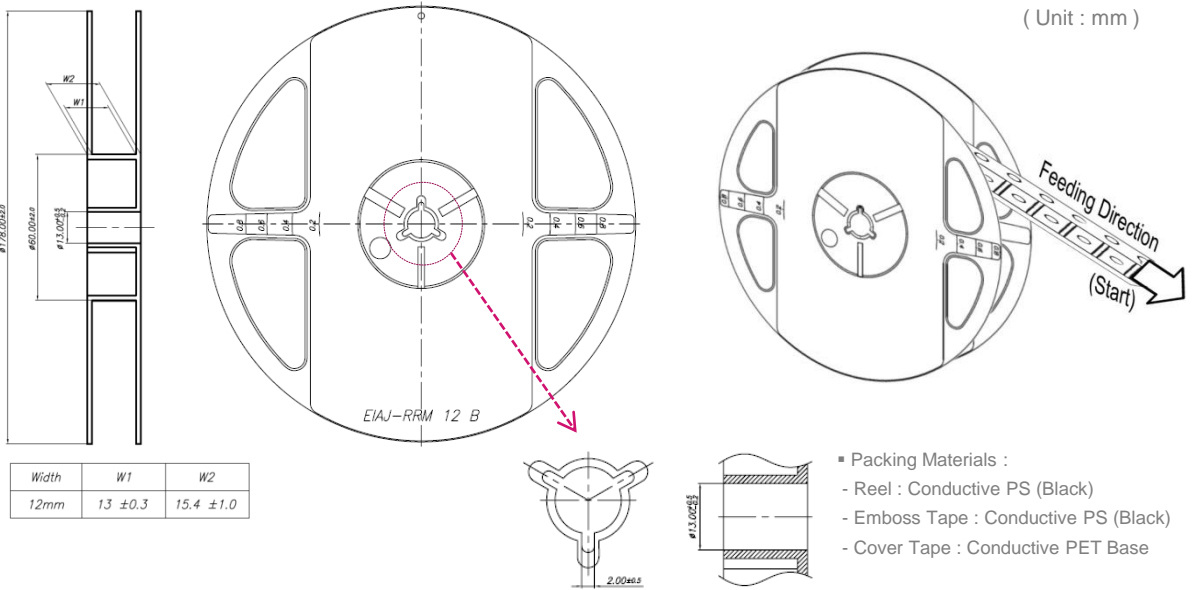

Tape

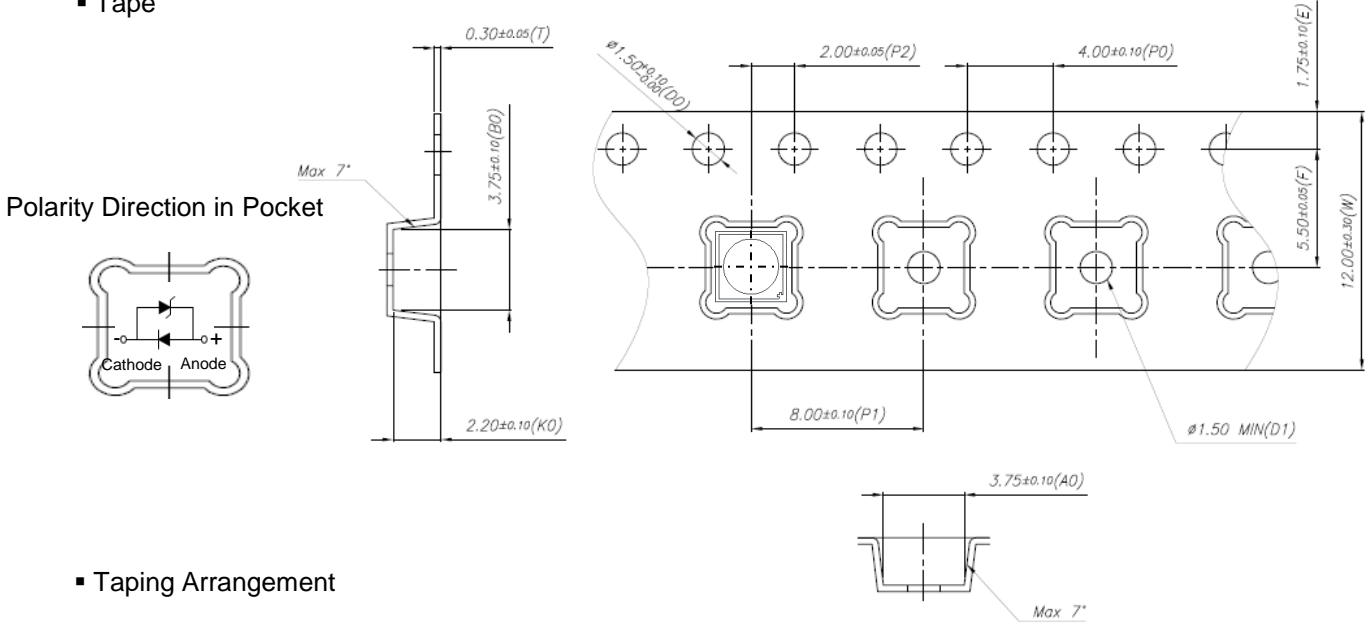

Taping Arrangement

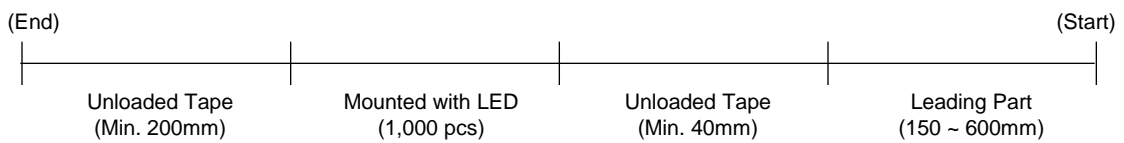

10. Packing and Labeling of Product

10-2. Packing Structures

Reeled products are packed in a sealed-off and moisture-proof aluminum bag with desiccants (silica gel) and HIC (Humidity Indicator Card). A maximum of four aluminum bags are packed in an inner box and six inner boxes are packed in an outer box.

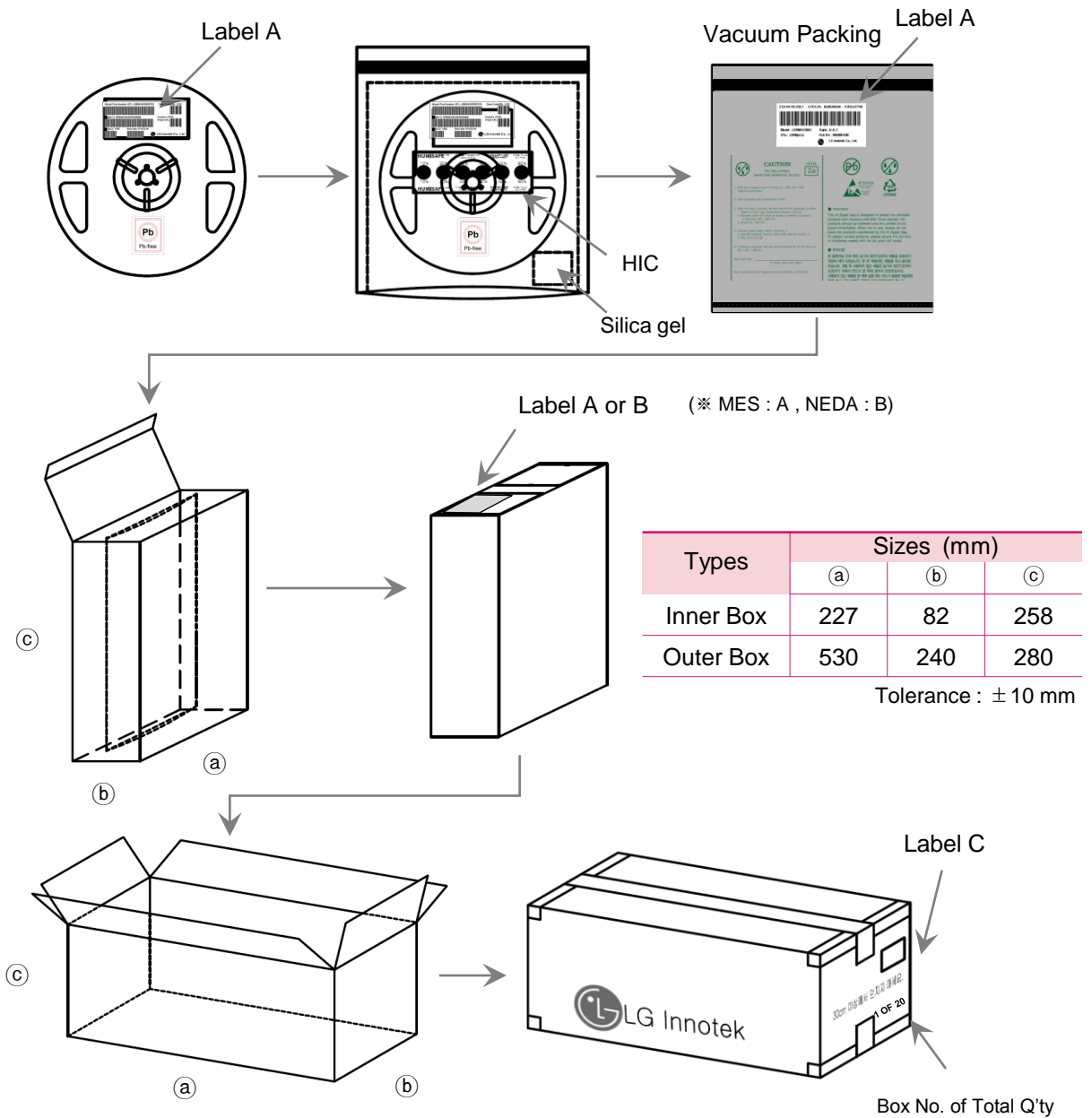

10. Packing and Labeling of Product

10-3. MES Label Structure

※. Label A

Specifying 'Lot ID', 'Model Name', 'MES ID', 'RANK', 'Q'ty', 'Run No', 'Rack No.'

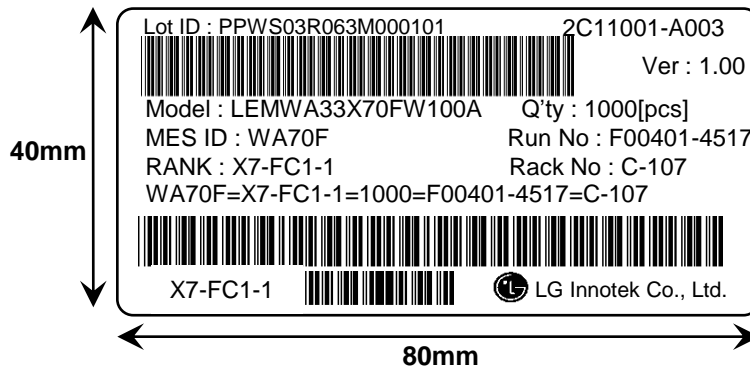

▪ Run No. indication

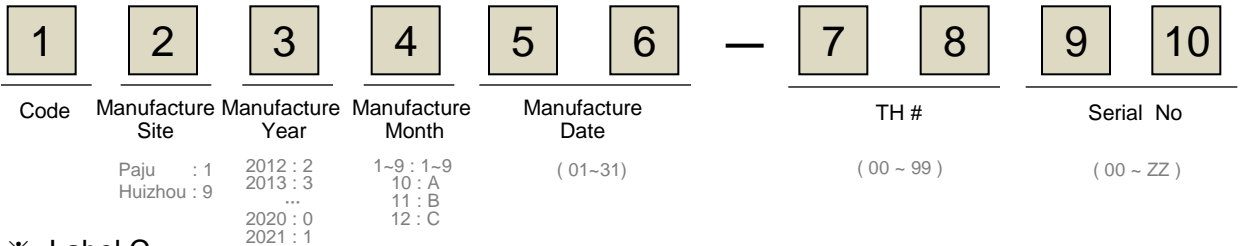

※. Label C

Specifying 'Customer', 'Date', 'Model Name', 'Quantity', 'Customer Part no', 'Outbox ID', 'LGIT Internal Model Name'

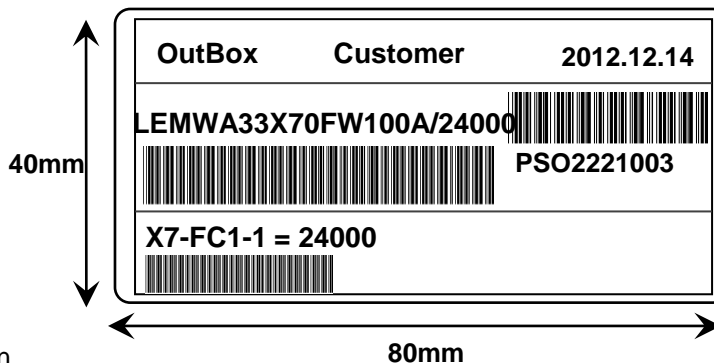

▪ Box ID. indication

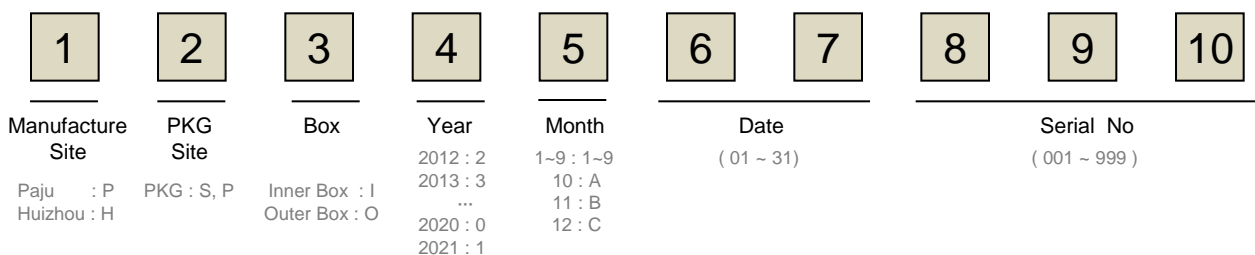

10. Packing and Labeling of Product

10-4. NEDA Label Structure

※ Label A

Specifying 'Manufacturing Part Number', 'Quantity', 'Bin Code', 'Lot', 'Date Code' and 'Country of Origin'

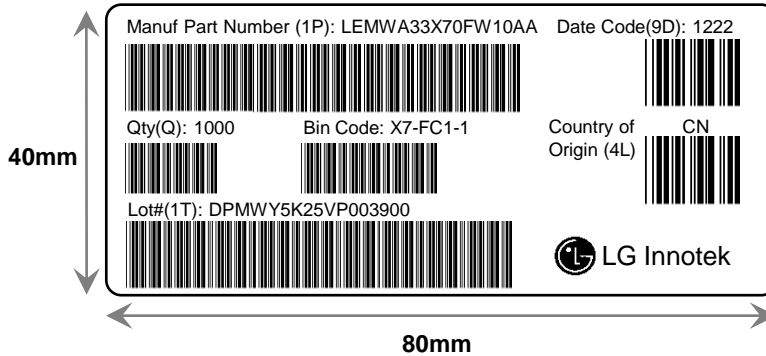

▪ Date Code(9D)

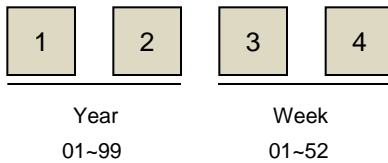

▪ Lot#(1T)

LG Innotek Trace Code

※ Label B

Specifying 'Manufacturing Part Number', 'Quantity', 'Bin Code', 'Trans ID', 'Date Code', 'Country of Origin' and 'Inner Box ID'

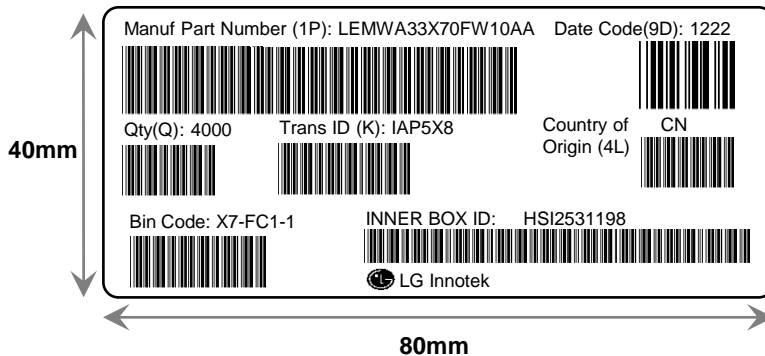

10. Packing and Labeling of Product

10-4. NEDA Label Structure

※ Label C

Specifying 'Manufacturing Site', 'Customer Address', 'Manufacturing Part Number', 'Bin Code', 'Box ID', 'Trans ID' and 'Quantity'

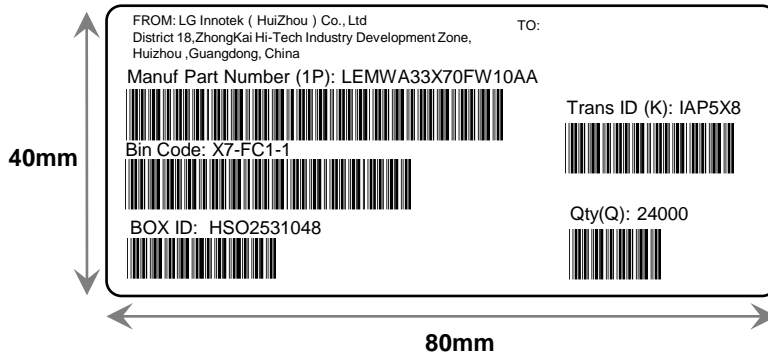

▪ Box ID Indication

1	2	3	4	5	6	7	8	9	10
Site	Code	Outbox	Year	Month	Date		Serial No		
Paju: P Huizhou: H	S, P	Outbox: O Inbox: I	12 : 2 13 : 3 14 : 4 15 : 5	1~9 : 1~9 10 : A 11 : B 12 : C	(01 ~ 31)		(001 ~ 999)		

11. Cautions on Use

11-1. Moisture-Proof Package

- The moisture in the SMD package may vaporize and expand during soldering.
- The moisture can damage the optical characteristics of the LEDs due to the encapsulation.

11-2. During Storage

Conditions		Temperature	Humidity	Time
Storage	Before Opening Aluminum Bag	5°C ~ 30°C	< 50% RH	Within 1 Year from the Delivery Date
	After Opening Aluminum Bag	5°C ~ 30°C	< 60% RH	≤ 672 Hours
Baking		65 ± 5°C	< 10%RH	10 ~ 24 Hours

11-3. During Usage

- The LED should avoid direct contact with hazardous materials such as sulfur, chlorine, phthalate, etc.
- The metal parts on the LED can rust when exposed to corrosive gases. Therefore, exposure to corrosive gases must be avoided during operation and storage.
- Extreme environments such as sudden ambient temperature changes or high humidity that can cause condensation must be avoided.

11-4. Cleaning

- Do not use brushes for cleaning or organic solvents (i.e. Acetone, TCE, etc..) for washing as they may damage the resin of the LEDs.
- Isopropyl Alcohol (IPA) is the recommended solvent for cleaning the LEDs under the following conditions.
Clearing Condition : IPA, 25°C max. × 60 sec max.
- Ultrasonic cleaning is not recommended.
- Pretests should be conducted with the actual cleaning process to validate that the process will not damage the LEDs.

11. Cautions on Use

11-5. Thermal Management

- The thermal design of the end product must be thoroughly considered, particularly at the beginning of the system design process.
- The generation of heat is greatly impacted by the input power, the thermal resistance of the circuit boards and the density of the LED array combined with other components.

11-6. Static Electricity

- Wristbands and anti-electrostatic gloves are strongly recommended and all devices, equipment and machinery must be properly grounded when handling the LEDs, which are sensitive against static electricity and surge.
- Precautions are to be taken against surge voltage to the equipment that mounts the LEDs.
- Unusual characteristics such as significant increase of current leakage, decrease of turn-on voltage, or non-operation at a low current can occur when the LED is damaged.

11-7. Recommended Circuit

- The current through each LED must not exceed the absolute maximum rating when designing the circuits.
- In general, the LED forward voltages can vary. LEDs in parallel that have different forward voltages in combination with a single resistor can result in different forward currents to each LED, which can also output different luminous flux values. In the worst case, the currents can exceed the absolute maximum ratings which can stress the LEDs. Matrix circuit with a single resistor for each LED is recommended to avoid luminous flux fluctuations.

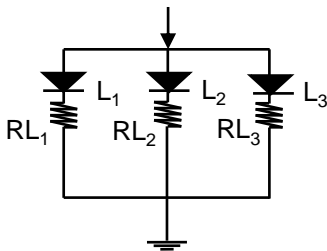

Fig.1 Recommended Circuit in Parallel Mode
: Separate resistors must be used for each LED.

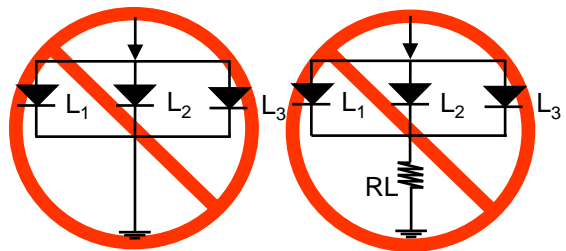

Fig.2. Abnormal Circuit
Circuits to Avoid: The current through the LEDs may vary due to the variation in LED forward voltage.

- The driving circuits must be designed to operate the LEDs by forward bias only.
- Reverse voltages can damage the zener diode, which can cause the LED to fail.
- A constant current LED driver is recommended to power the LEDs.

11. Cautions on Use

11-8. Soldering Conditions

- Reflow soldering is the recommended method for assembling LEDs on a circuit board.
- LG Innotek does not guarantee the performance of the LEDs assembled by the dip soldering method.
- Recommended Soldering Profile (according to JEDEC J-STD-020D)

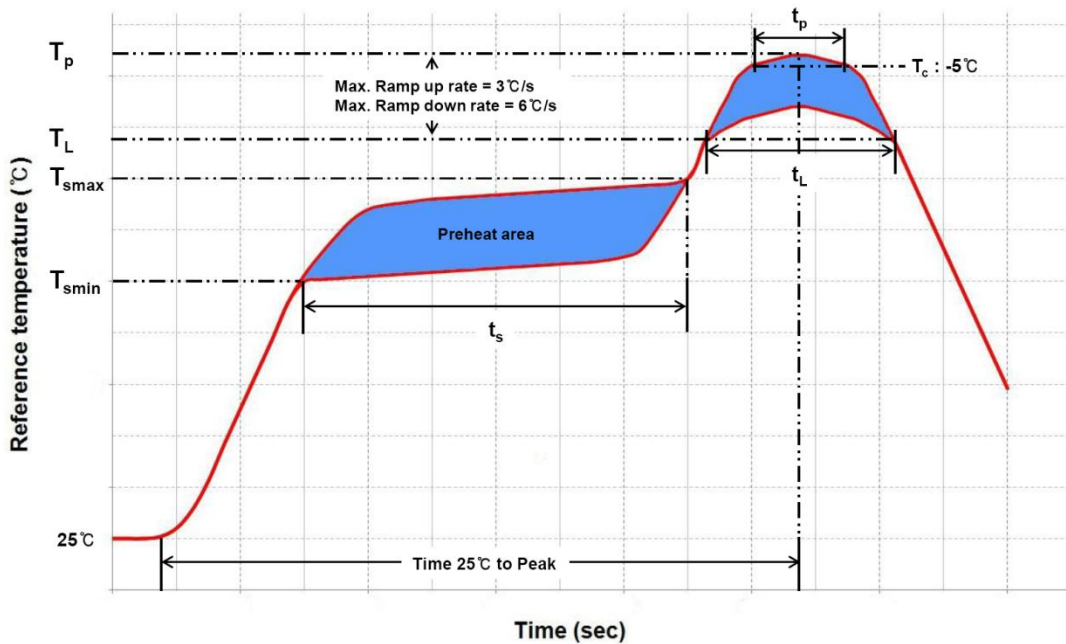

Profile Feature	Pb-Free Assembly	Pb-Based Assembly
Preheat/Soak		
Temperature Min(T_{smin})	150°C	100°C
Temperature Max(T_{smax})	200°C	150°C
Maximum time(t_s) from T_{smin} to T_{smax}	60~120 seconds	60~120 seconds
Ramp-up rate (T_L to T_p)	3°C/ second max.	3°C/ second max.
Liquidous temperature (T_L)	217°C	183°C
Time (t_L) maintained above T_L	60~150 seconds	60~150 seconds
Maximum peak package body temperature (T_p)	260°C	235°C
Time(t_p) within 5°C of the specified temperature (T_c)	30 seconds	20 seconds
Ramp-down rate (T_p to T_L)	6°C/second max.	6°C/second max.
Maximum Time 25°C to peak temperature	8 minutes max.	6 minutes max.

- Reflow or hand soldering at the lowest possible temperature is desirable for the LEDs although the recommended soldering conditions are specified in the above diagrams.
- A rapid cooling process is not recommended for the LEDs from the peak temperature.
- The silicone lens at the top of the LED package is a soft surface, which can easily be damaged by pressure. Precautions should be taken to avoid strong pressure on the silicone lens when leveraging the pick and place machines.
- Reflow soldering should not be done more than two times.

11. Cautions on Use

11-9. Soldering Iron

- The recommended condition is less than 5 seconds at 260 °C.
- The time must be shorter for higher temperatures. (+10 °C → -1sec).
- The power dissipation of the soldering iron should be lower than 15W and the surface temperature of the device should be controlled at or under 230 °C.

11-10. Eye Safety Guidelines

- Do not directly look at the light when the LEDs are on.
- Proceed with caution to avoid the risk of damage to the eyes when examining the LEDs with optical instruments.

11-11. Manual Handling

- Use Teflon-type tweezers to grab the base of the LED and do not apply mechanical pressure on the surface of the encapsulant.

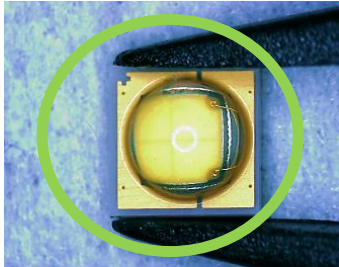

Appendix. Package Nomenclature

All LEDs are tested and sorted by color, luminous flux and forward voltage where every LED in a tube has only a single color bin, luminous flux bin and forward voltage bin. However, the forward voltage bin information is not captured in the part number nomenclature.

A 16-digit part number is required when orders are placed. LG Innotek leverages the following part number nomenclature.

