

Version	Date	Change Note	Approved
V1.0	20170302	First edictor	
	20170908	1.560R电阻改为二极管D90015 2.去掉电阻R89545	
		1.电阻R90029由NC改为上件. 2.加了一个22uF/25V电容, C31. 3.去掉HDMIIN_HPDP所连电阻.	
v1.3	20171107	1.EDP PANEL 增加DC-DC电路, VCC5V0转VCC 3V3 EDP. 2.LCD屏处增加8个NMOS管, 电平转换电路, 增加一个DC-DC电路, VCC5V0_SYS转VCC_1V8_LCD. 3.SATA处U90012输出部分增加三个滤波电容C31,C90102,C90103. 4.U2102的第9脚串联一个D90015. 5.C50007处并联一个R90341 51K电阻. 6.将网络LOG_DVS_PWM用电阻R2212上拉至VCC 3V0. 7.去掉MIPI_CAMERA模块处的排阻 RN1,RN2,R90291,R90292.	
v1.4	20171211	1.C90052,R90222, D90012,R90224 NC,C90048换成105F,R2119换成10K 2.将R90232,R90233与C90058,C90059互换 3.R90223换成10K,Q65025去掉, 将R90223的第1脚接VCC_DC 第二脚接GND 4.R2209,R2210,R2211,R2212,R2213,R2214换成1%的电阻	

<b>Xunlong Software</b>			
Design Name			
<b>Orangepi-RK3399</b>			
Size	Page Name		Rev
A4	<b>VERSION HISTORY</b>		1.4
Date:	Tuesday, December 12, 2017	Sheet	1 of 30

# RK3399 I2C MAP

Port	Pin name	Domain	Bus name	Pull-up voltage	Slave Device	Slave Addr (MS 7Bits)	Note	Slave Bus Capability
I2C0	GPIO1_B7/SPI3_RXD/I2C0_SDA GPIO1_C0/SPI3_TXD/I2C0_SCL	PMUIO2 VCC1V8_PMU	I2C_SDA_PMIC I2C_SCL_PMIC	VCC1V8_PMU	TI LP8752-Q1	0x60	DC regulator	100kHz,400kHz,1MHz fast mode+ 3.4MHz high-speed mode
					Rockchip RK808	0x1b	PMIC	
					Fairchild FUSB302B	0x44,0x46	USB-TypeC Mux	100kHz,400kHz,1MHz fast mode+
I2C1	GPIO4_A1/I2C1_SDA GPIO4_A2/I2C1_SCL	APIO5 VCC1V8_IO	I2C_SDA_AUDIO I2C_SCL_AUDIO	VCCA1V8_CODEC	Everest ES8316	0x10	Audio codec	
			I2C_SDA_CAM I2C_SCL_CAM	VCCA1V8_CODEC	Omnivision OV8858	0x6c,0x20	MIPI Camera	
I2C2	GPIO2_A0/VOP_D0/CIF_D0/I2C2_SDA GPIO2_A1/VOP_D1/CIF_D1/I2C2_SCL	APIO2 VCC1V8_IO	Other pin function					
I2C3	GPIO4_C0/I2C3_SDA/UART2B_RX GPIO4_C1/I2C3_SCL/UART2B_TX	APIO4 VCC3V0_IO	I2C_SDA_HDMI I2C_SCL_HDMI	VCC3V0_IO				
I2C4	GPIO1_B3/I2C4_SDA GPIO1_B4/I2C4_SCL	PMUIO2 VCC1V8_IO	I2C_SDA_MEMS I2C_SCL_MEMS	VCC1V8_PMU	Capellamicro CM3218	0x10,0x0c	ALS Sensor	
					AsahiKasei AK8963C		Compass	
					InverSense MPU6500	0x34	Accer+Gyro	
			I2C_SDA_TOUCH I2C_SCL_TOUCH	VCC1V8_TOUCH	Silead GSL3680	0x40	Touch panel	
I2C5	GPIO3_B2/MAC_RXER/I2C5_SDA GPIO3_B3/MAC_CLK/I2C5_SCL	APIO1 VCC3V3_LAN	I2C_SDA_PCIE I2C_SCL_PCIE	VCC3V3_IO				
I2C6	GPIO2_B1/SPI2_RXD/CIF_HREF/I2C6_SDA GPIO2_B2/SPI2_TXD/CIF_CLKIN/I2C6_SCL	APIO2 VCC1V8_IO	I2C_SDA_BAT I2C_SCL_BAT	VCC1V8_DVP	Chrome Battery	0x19	Battery	100kHz
					TI BQ25700	0x6a (I2C) 0x09 (SMBus)	Charger	
					Fairchild FUSB302B	0x44,0x46	USB-TypeC Mux	100kHz,400kHz,1MHz fast mode+
I2C7	GPIO2_A7/VOP_D7/CIF_D7/I2C7_SDA GPIO2_B0/VOP_CLK/CIF_VSYNC/I2C7_SCL	APIO2 VCC1V8_IO	Other pin function					

<b>Xunlong Software</b>			
Design Name			
<b>Orangepi-RK3399</b>			
Size	Page Name		Rev
A4	<b>I2C MAP</b>		1.4
Date: <b>Tuesday, December 12, 2017</b> Sheet <b>2</b> of <b>30</b>			

5

4

3

2

1

D

D

C

C

B

B

A

A

<b><i>Xunlong Software</i></b>		
Design Name		
<b>Orangepi-RK3399</b>		
Size	Page Name	Rev
A4	<b>PWOER DOMAIN</b>	1.4
Date:	Tuesday, December 12, 2017	Sheet 3 of 30

5

4

3

2

1

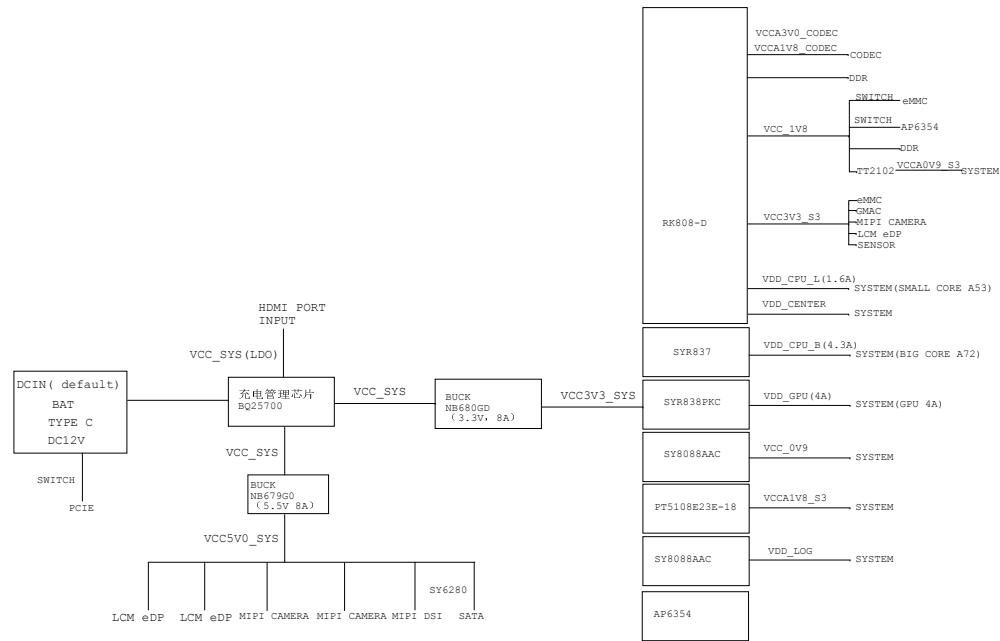

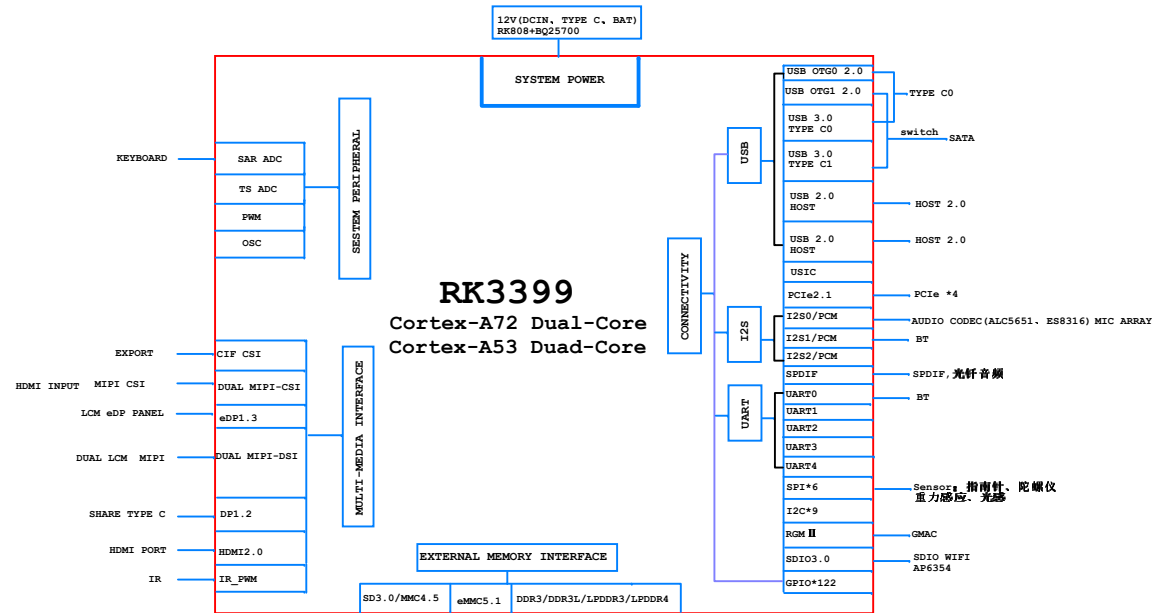

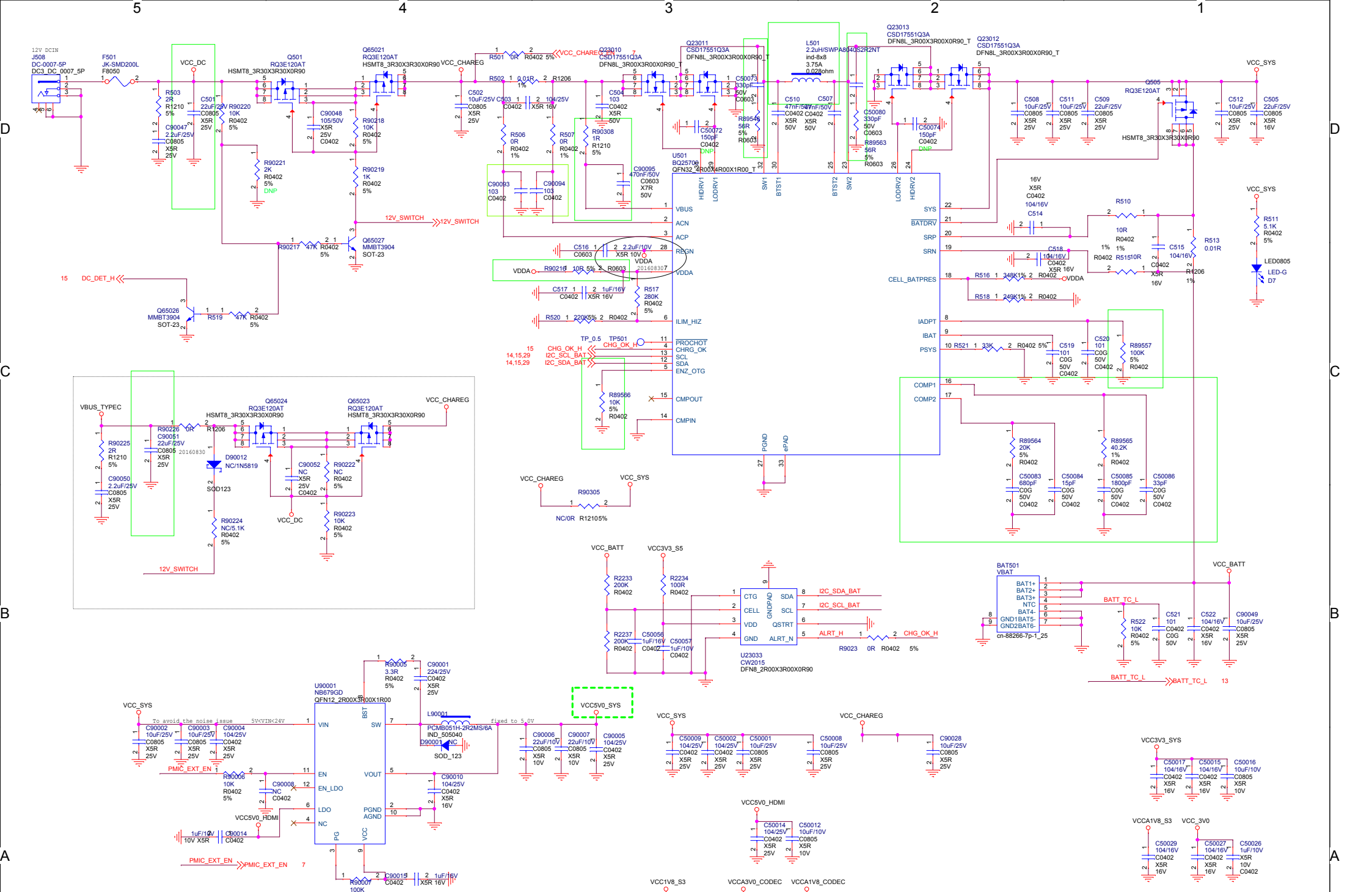

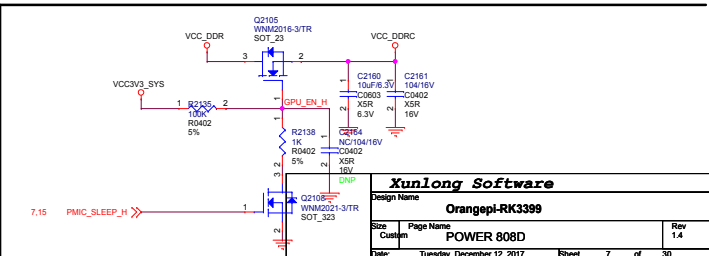
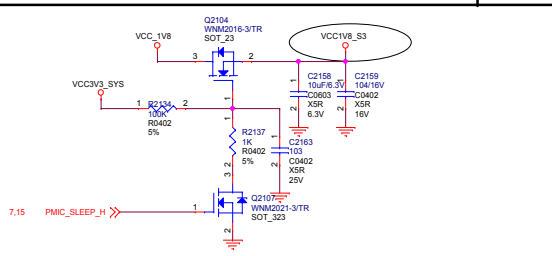
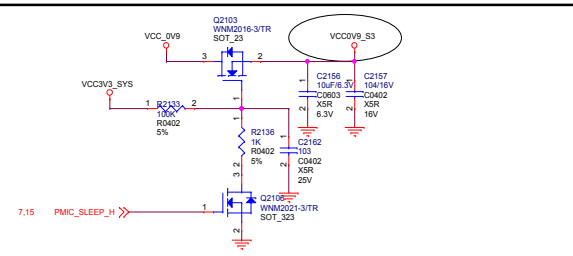
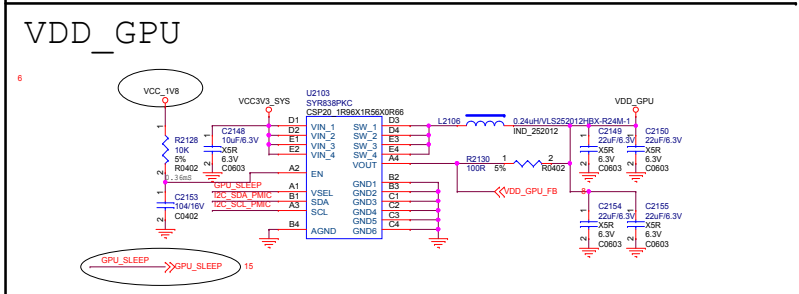
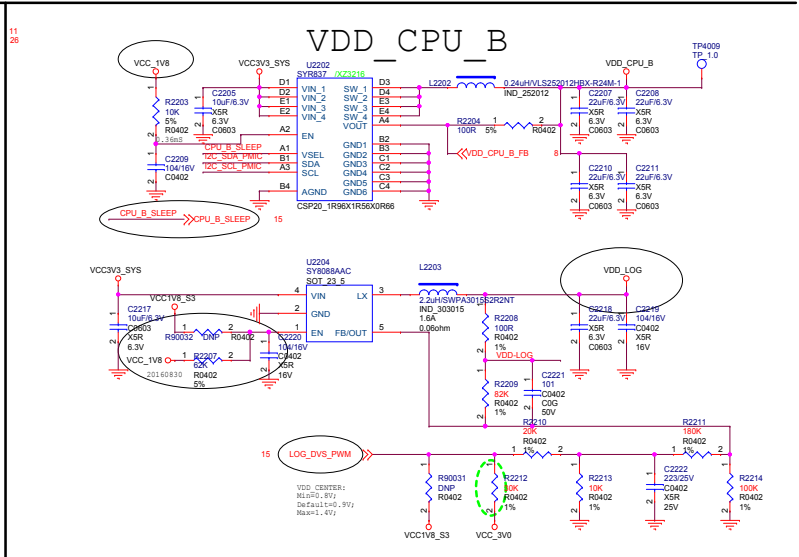
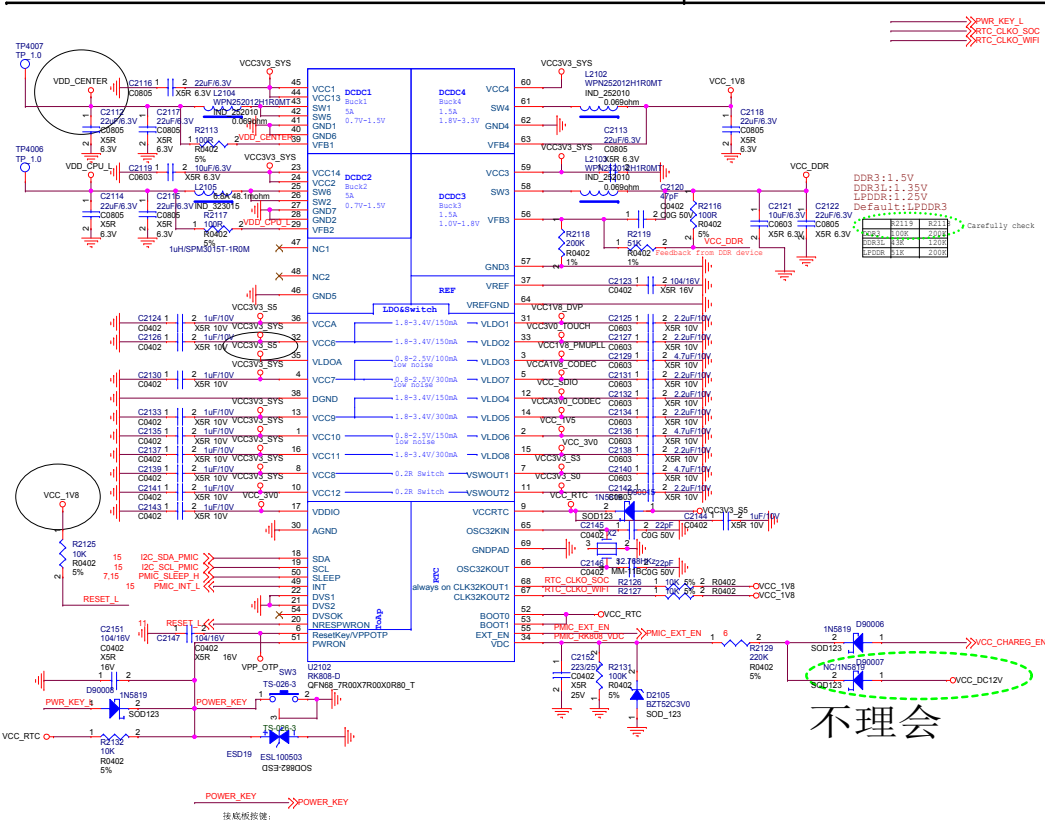
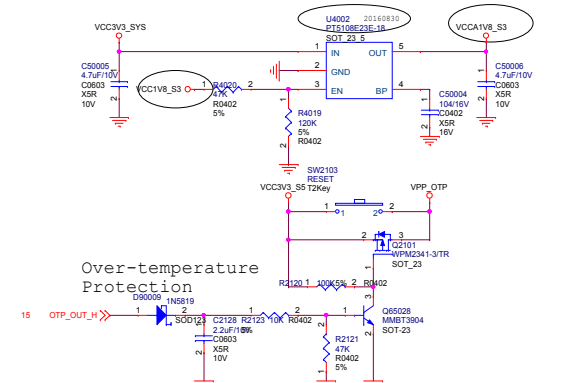
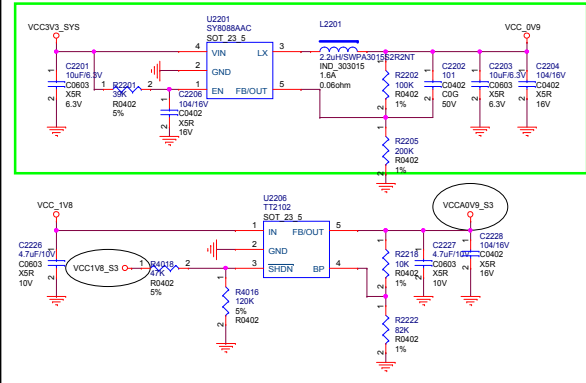
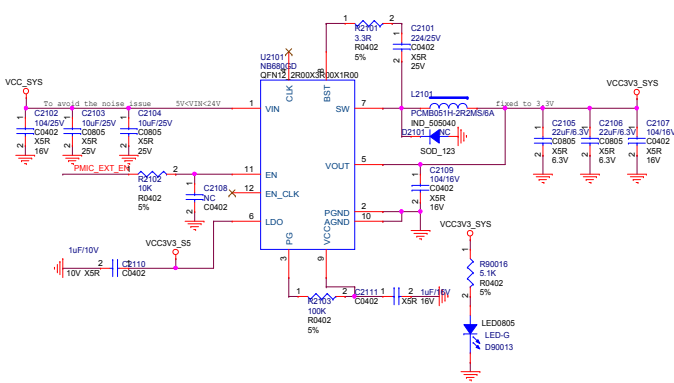

不理會

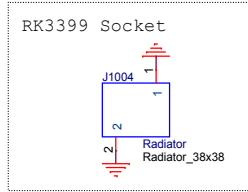
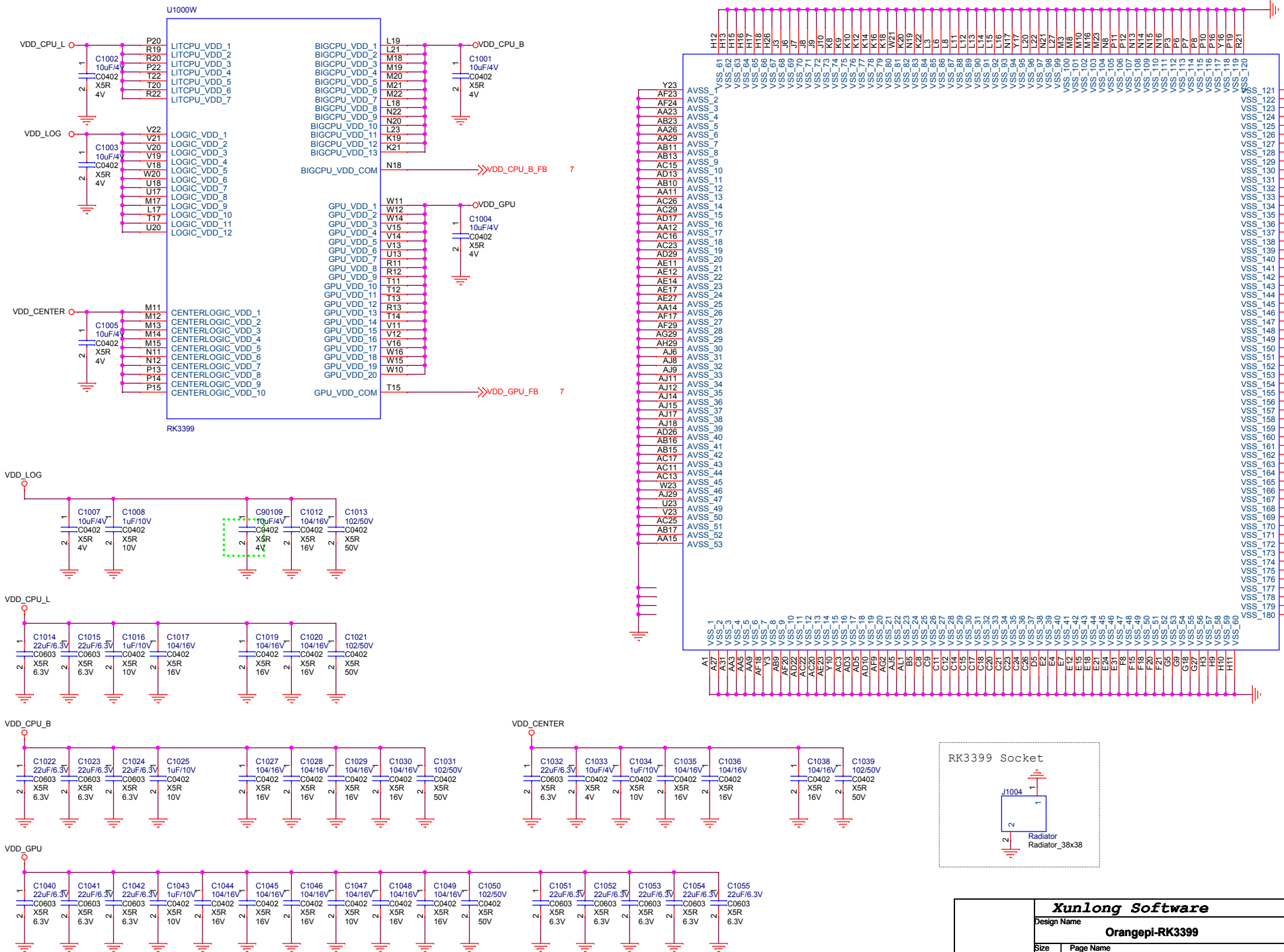



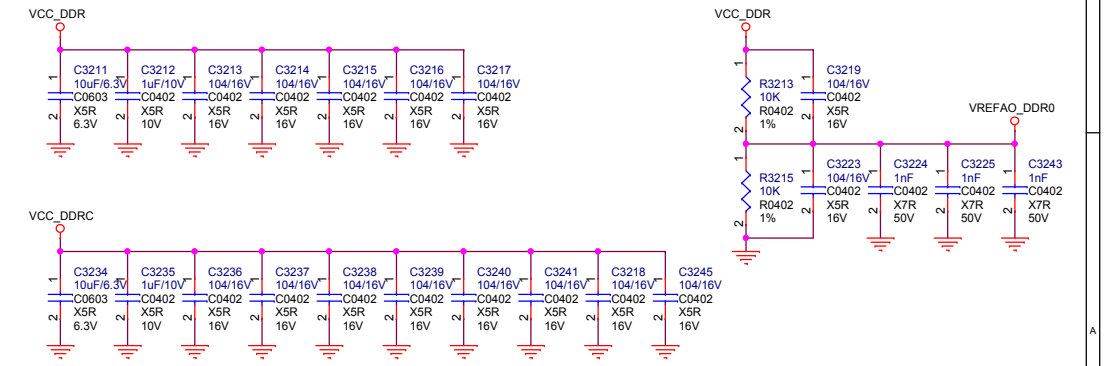
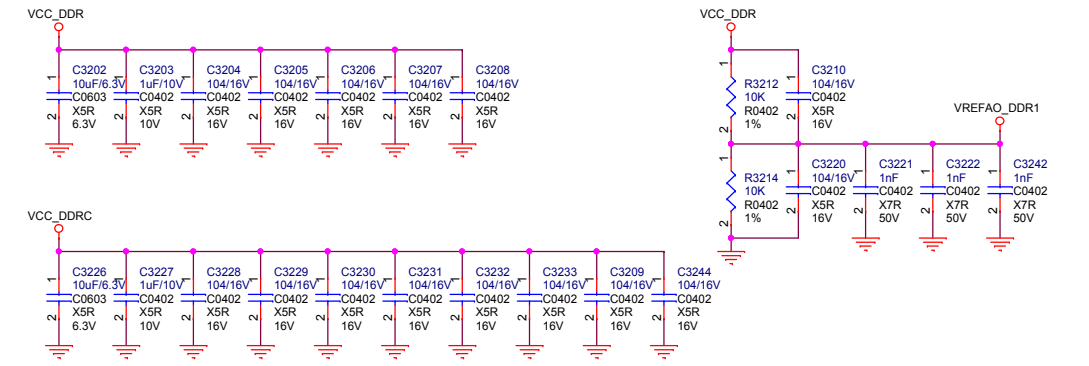
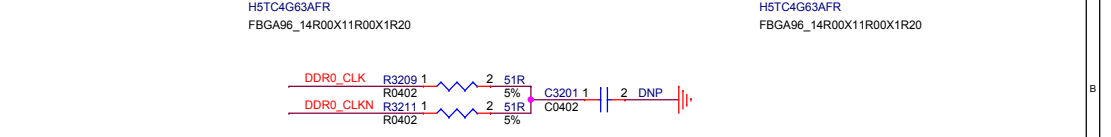
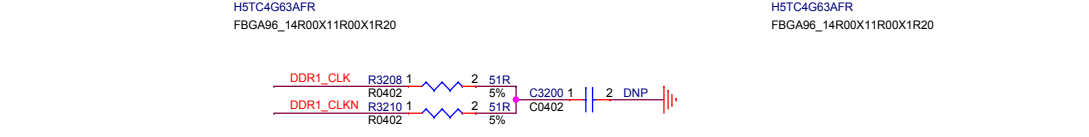
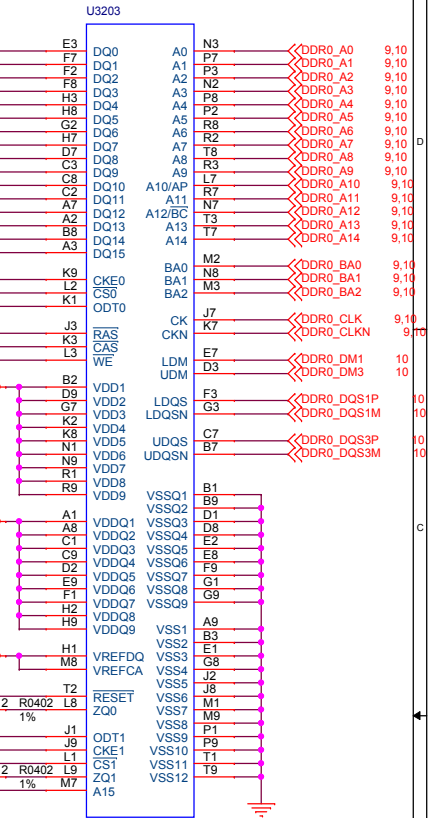
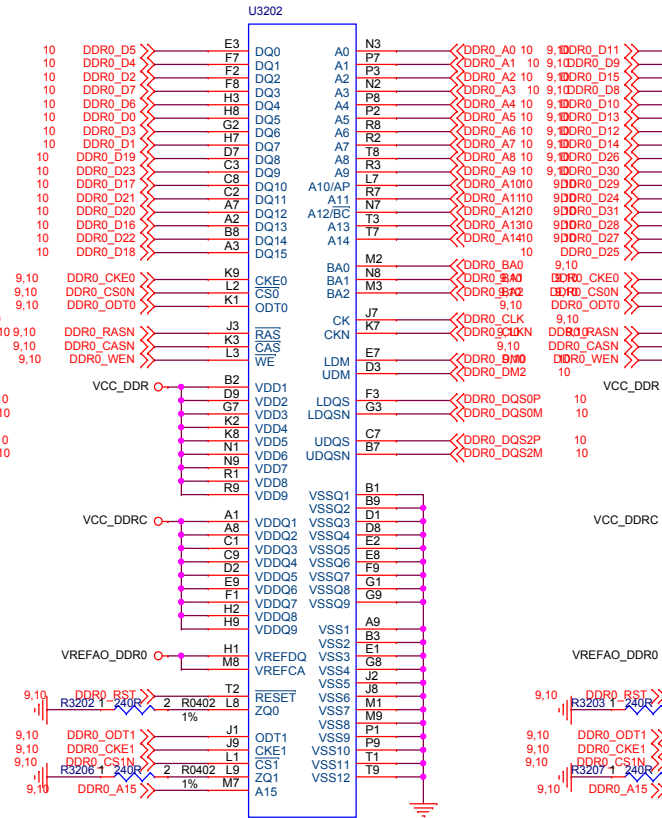
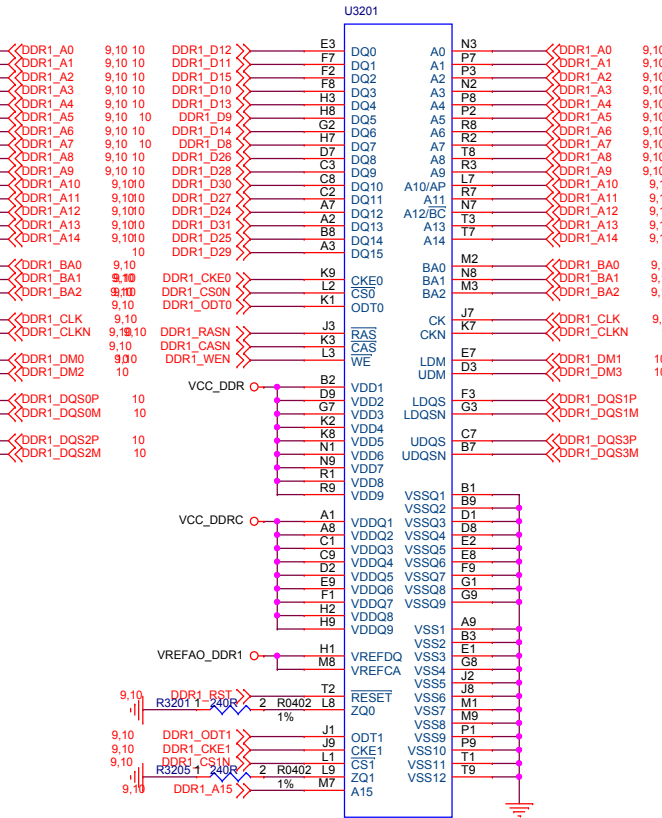
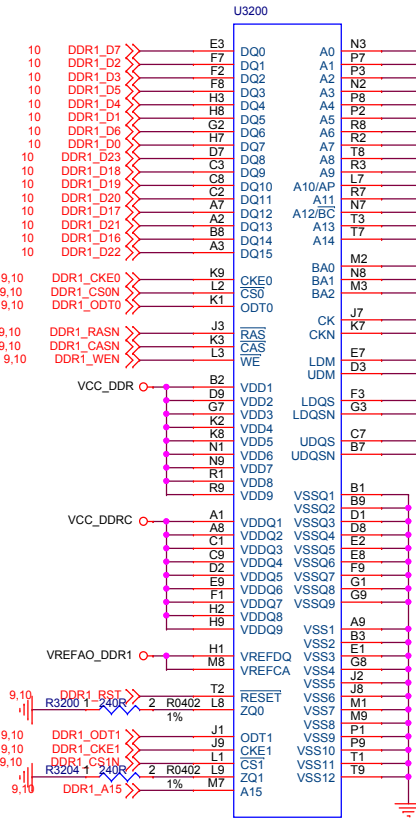

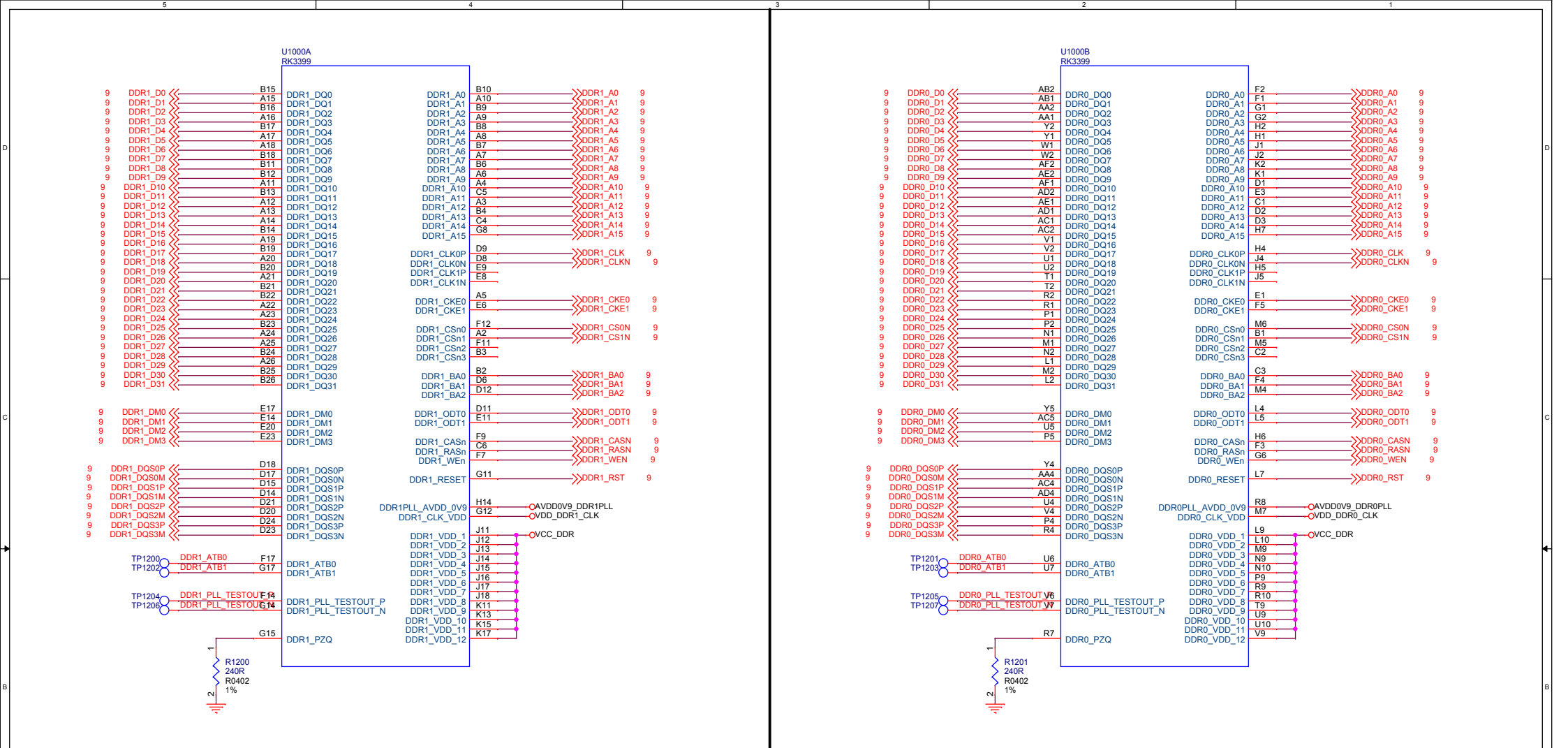

DDR FILTER

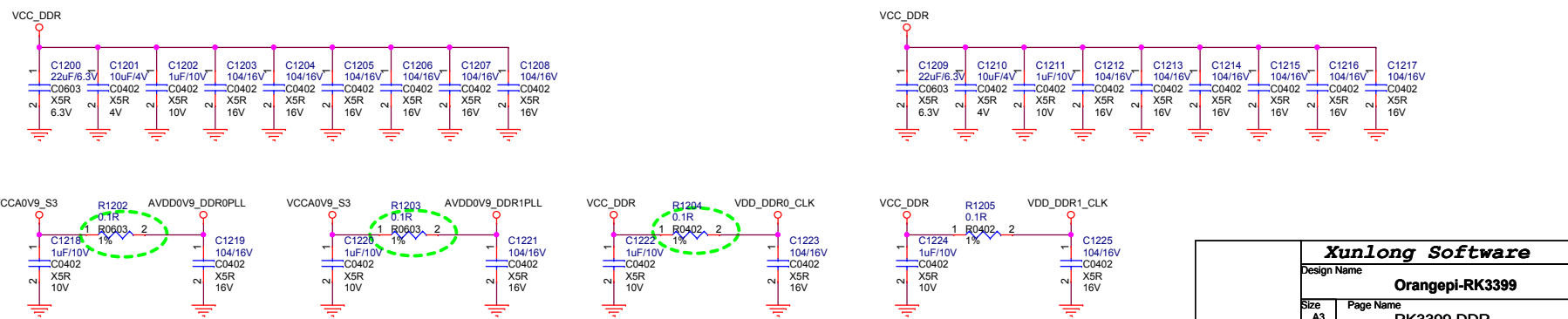

<b>Xunlong Software</b>		
Design Name		
<b>Orangepi-RK3399</b>		
Size	Page Name	Rev
A3	RK3399 DDR	1.4
Date:	Tuesday, December 12, 2017	Sheet 10 of 30

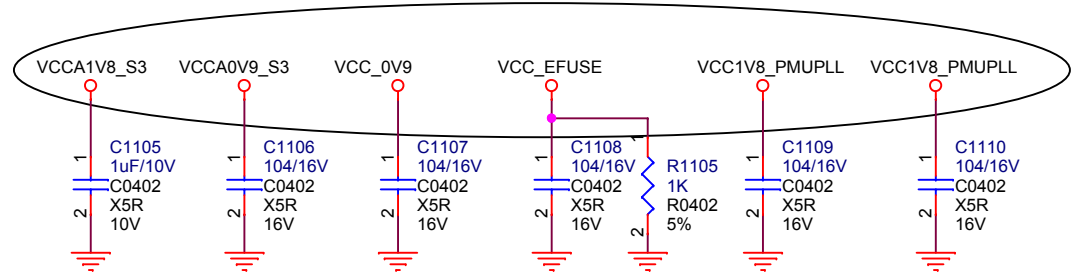
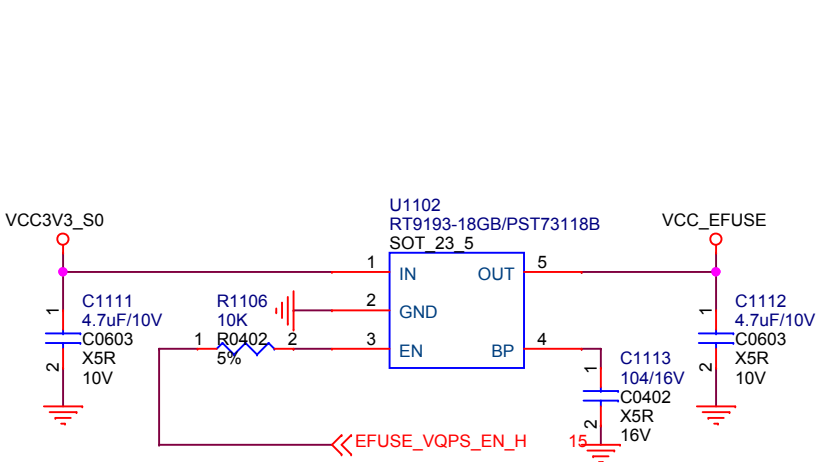
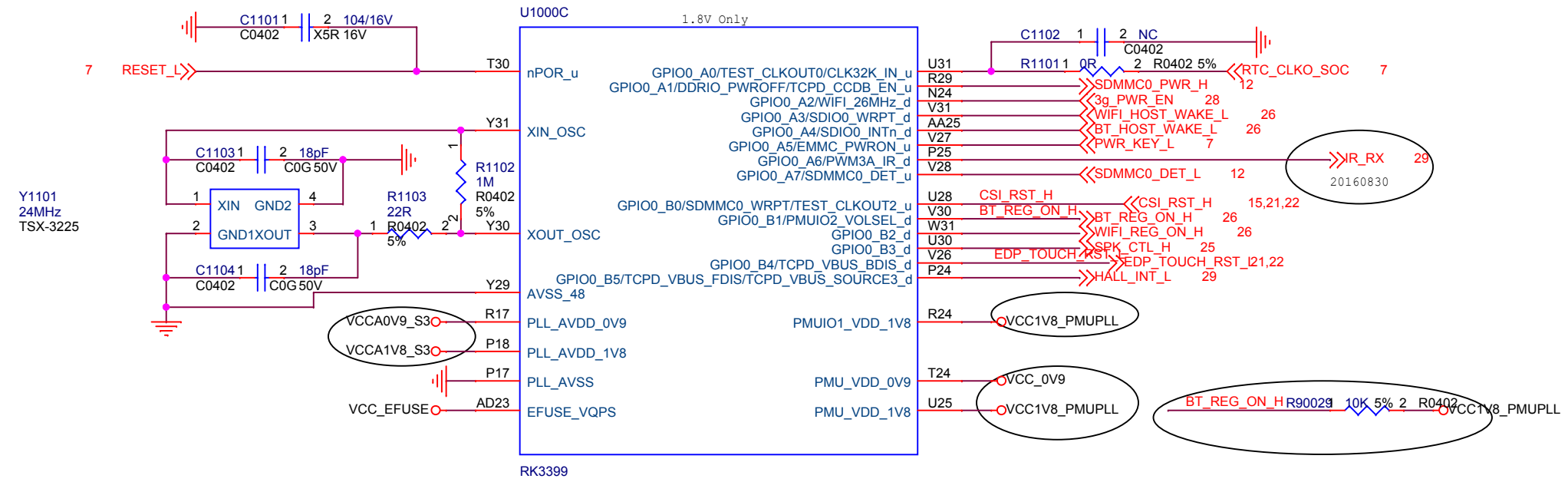

<b>Xunlong Software</b>		
Design Name		
<b>Orangepi-RK3399</b>		
Size	Page Name	Rev
A4	<b>RK3399 PMU</b>	1.4
Date:	Tuesday, December 12, 2017	Sheet 11 of 30

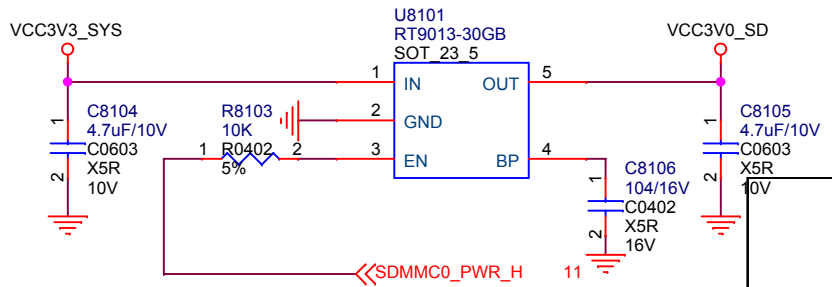
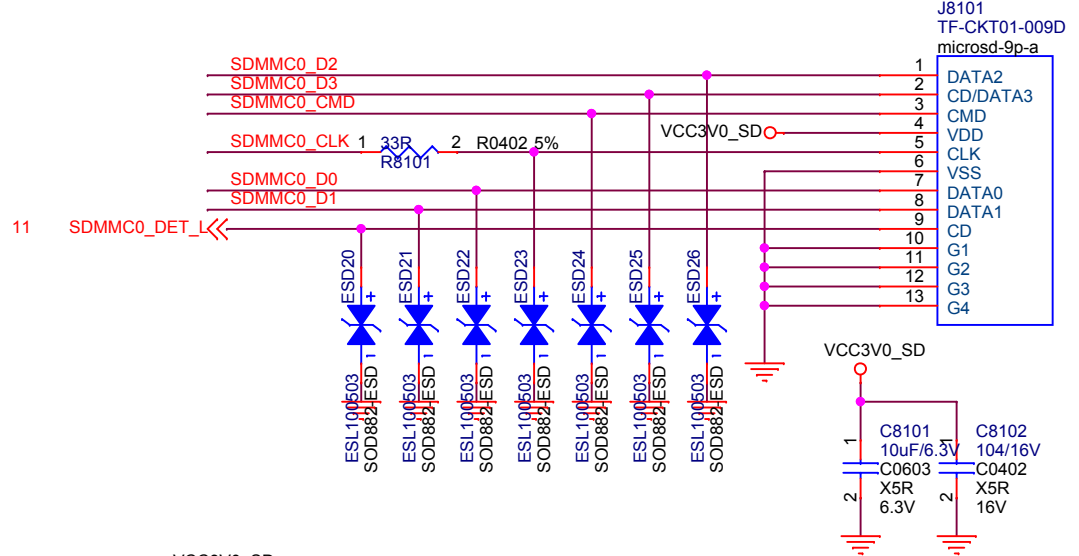
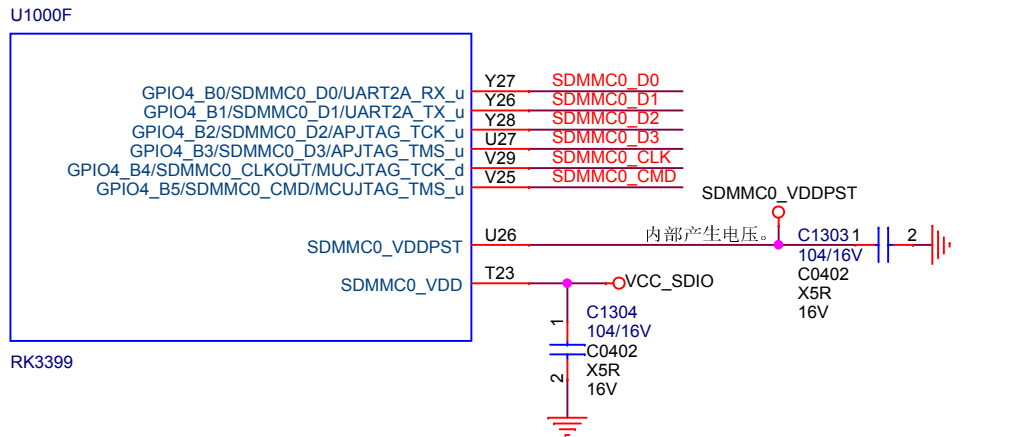
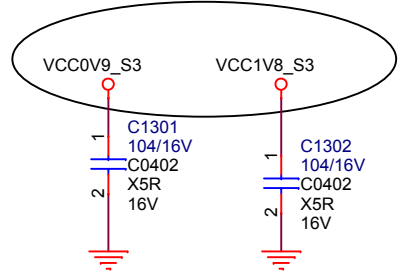
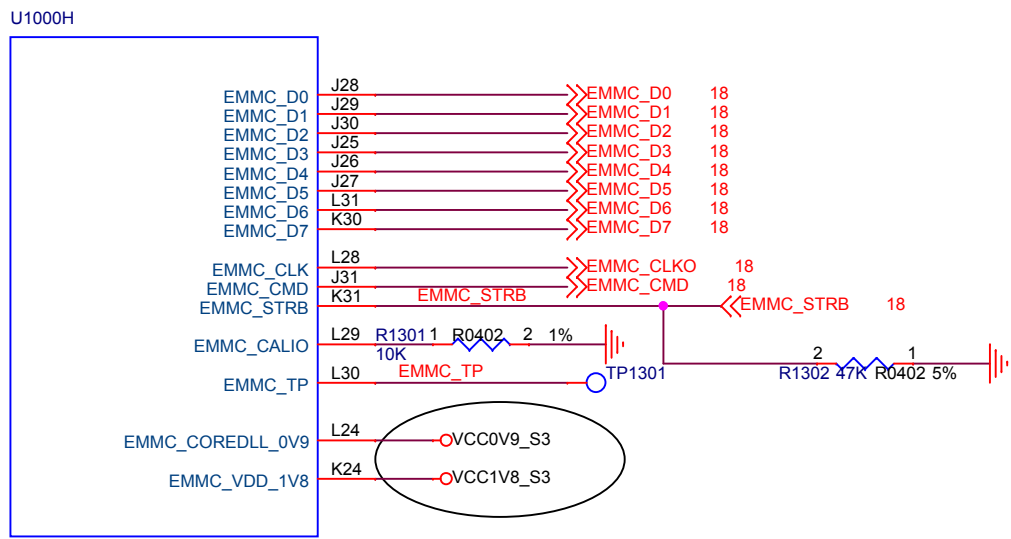

<b>Xunlong Software</b>		
Design Name		
<b>Orangepi-RK3399</b>		
Size	Page Name	Rev
A4	RK3399 eMMC TF	1.4
Date:	Tuesday, December 12, 2017	Sheet 12 of 30

U1000V

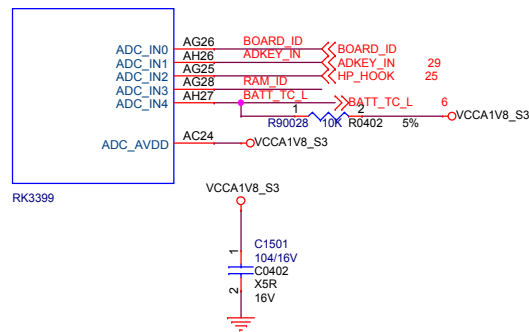

RK3399

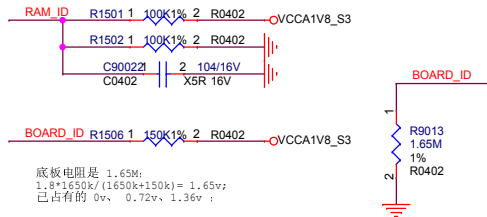
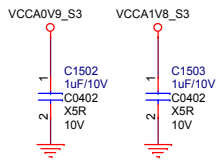

底板电阻是 1.65M;  
 $1.8 \times 1650k / (1650k + 150k) = 1.65v$ ;  
 已占有的 0v、0.72v、1.36v ;

U1000O

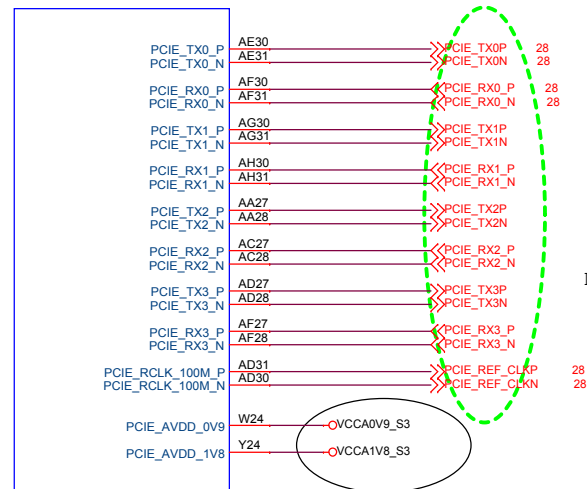

RK3399

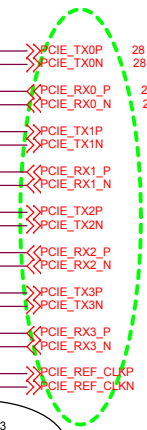

Don't ignore, No use to

<b>Xunlong Software</b>		
Design Name		
<b>Orangepi-RK3399</b>		
Size	Page Name	Rev
A3	HOST	1.4
Date:	Tuesday, December 12, 2017	Sheet 13 of 30



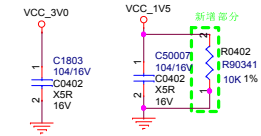
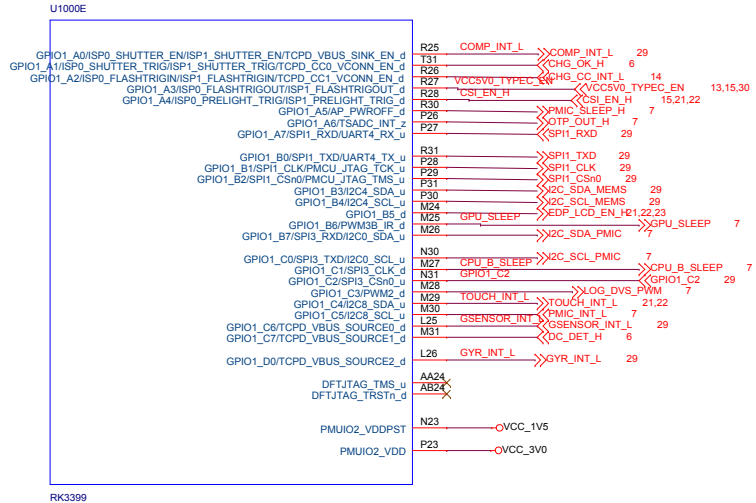
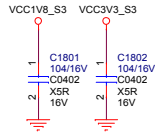
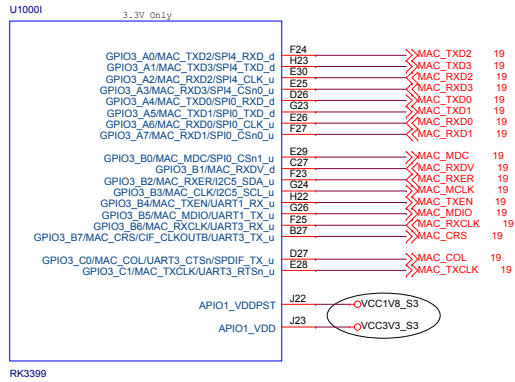

1.8V Only	VDDPST=VDDIO=1.8V
3.3V Only	VDDPST=1.8V, VDDIO=3.3V
other	3.0V mode: VDDPST=1.5V, VDDIO=3.0V 1.8V mode: VDDPST=1.8V, VDDIO=1.8V

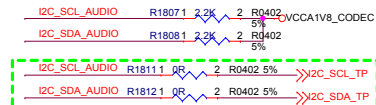
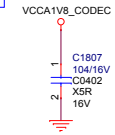
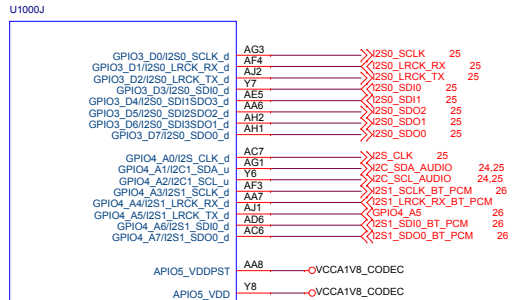
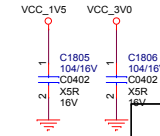
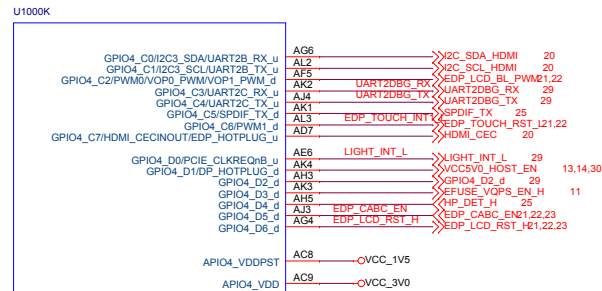
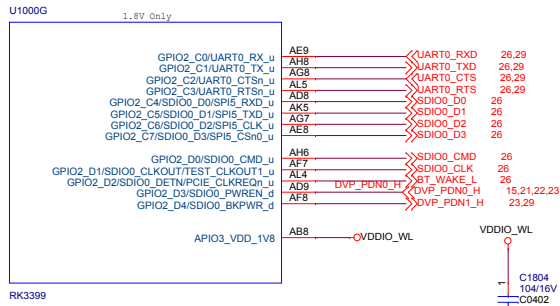
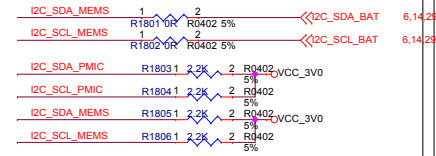

**Xunlong Software**

Design Name  
**OrangePi-RK3399**

Size Page Name  
Custom RK3399 GPIO

Date: Tuesday, December 12, 2017 Sheet 15 of 30

Rev 1.4

U1000L

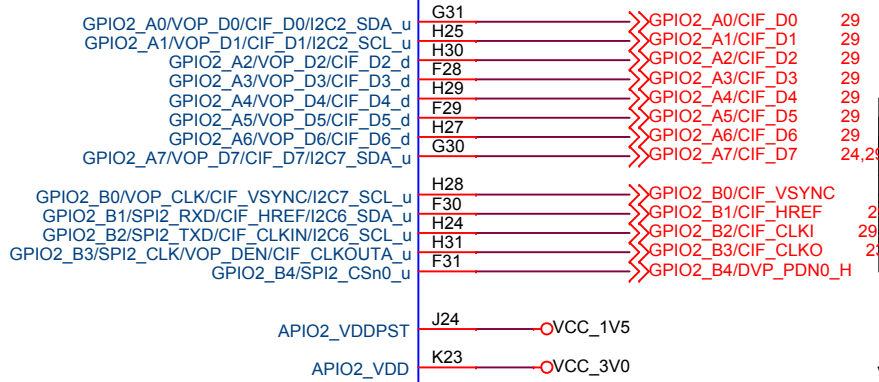

func1	func2	func3
GPIO2 A0/CIF D0		I2C2 SDA
GPIO2 A1/CIF D1		I2C2 SCL
GPIO2 A7/CIF D7		I2C7 SDA
GPIO2 B0/CIF VSYNC		I2C7 SCL
GPIO2 B1/CIF HREF	SPI2 RXD	I2C6 SDA
GPIO2 B2/CIF CLKI	SPI2 TXD	I2C6 SCL
GPIO2 B3/CIF CLKO	SPI2 CLK	
GPIO2 B4/DVP PDN0 H	SPI2 CSN	

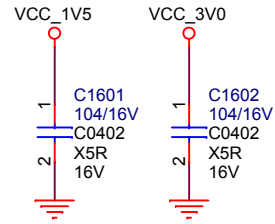

RK3399

U1000R

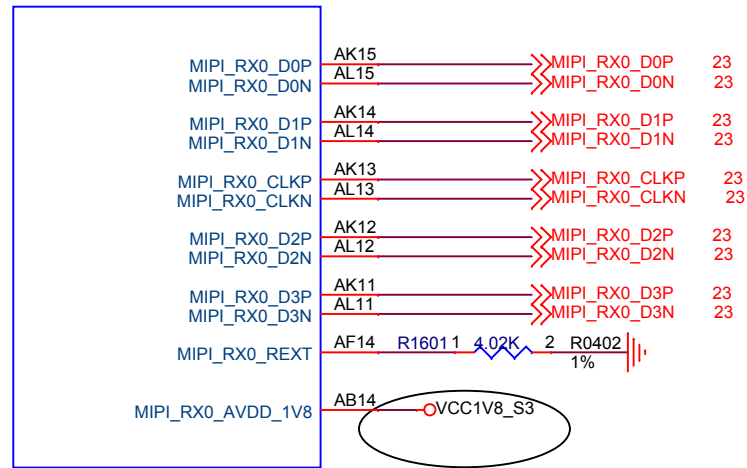

RK3399

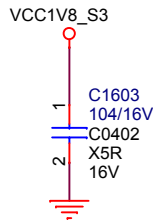

U1000P

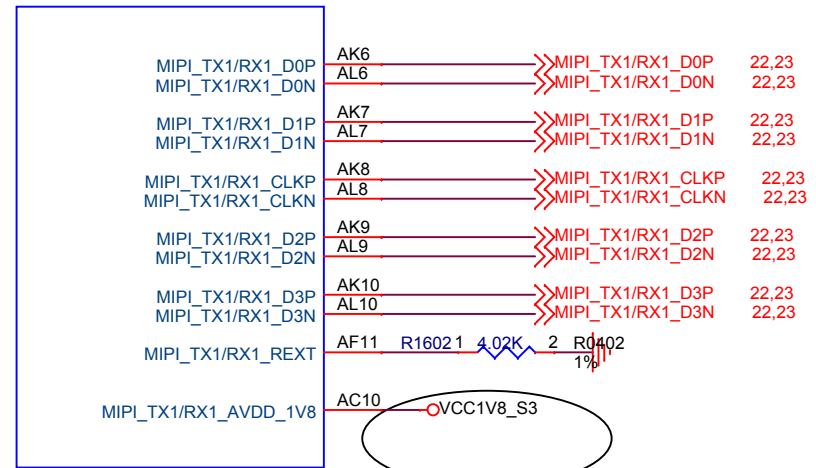

RK3399

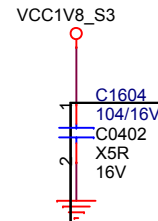

**Xunlong Software**

**Design Name**  
**Orangepi-RK3399**

<b>Size</b> A4	<b>Page Name</b> RK3399 DVP	<b>Rev</b> 1.4
<b>Date:</b> Tuesday, December 12, 2017		<b>Sheet</b> 16 <b>of</b> 30



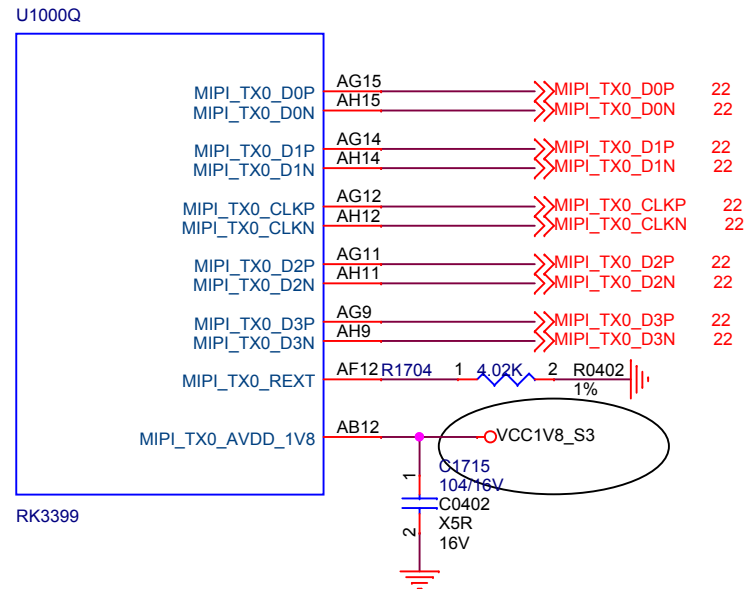
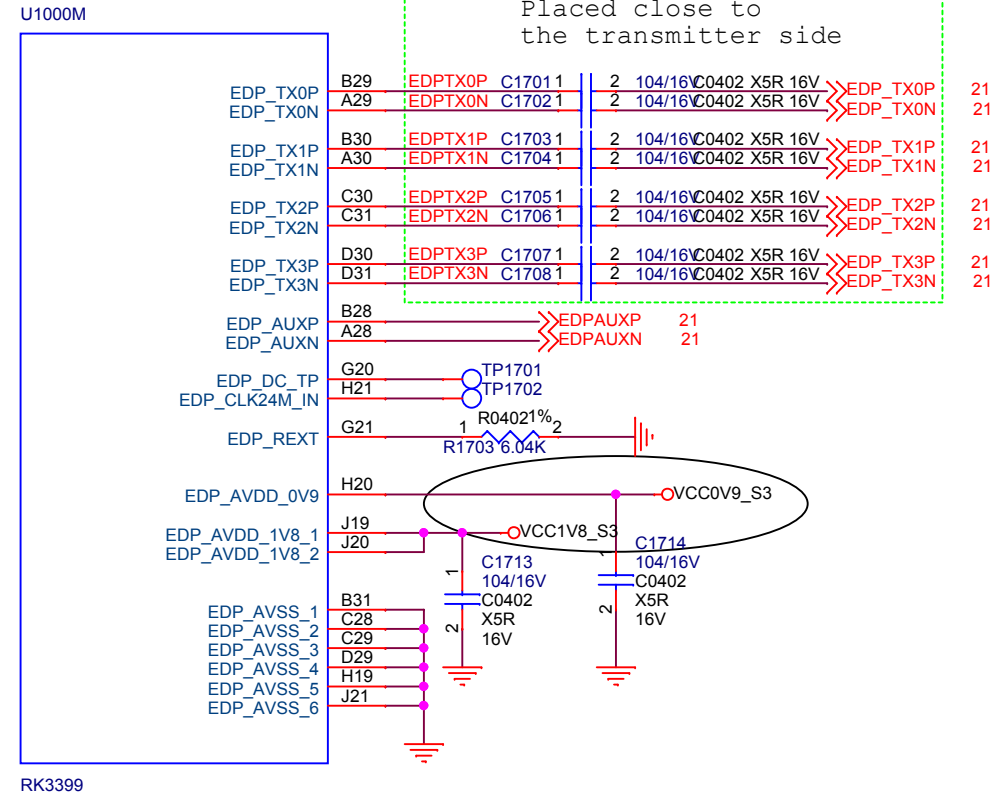
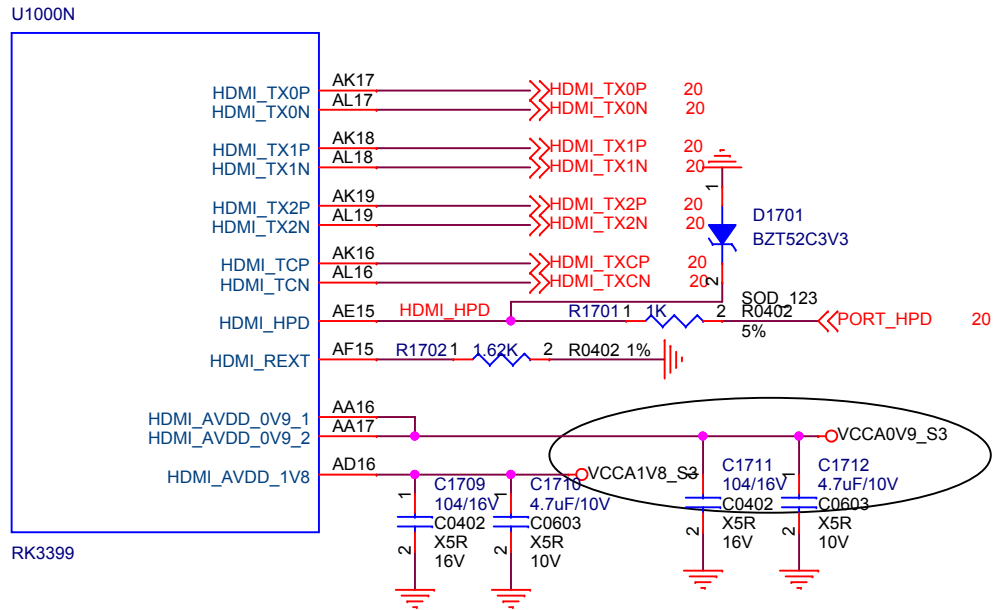

<b>Xunlong Software</b>		
Design Name		
<b>Orangepi-RK3399</b>		
Size	Page Name	Rev
A4	<b>RK3399 display</b>	1.4
Date:	Tuesday, December 12, 2017	Sheet 17 of 30

# eMMC FLASH

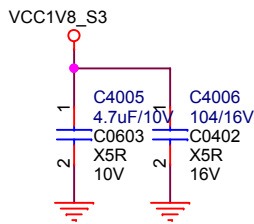
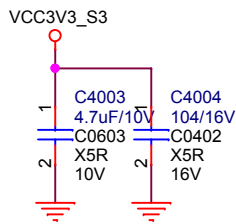
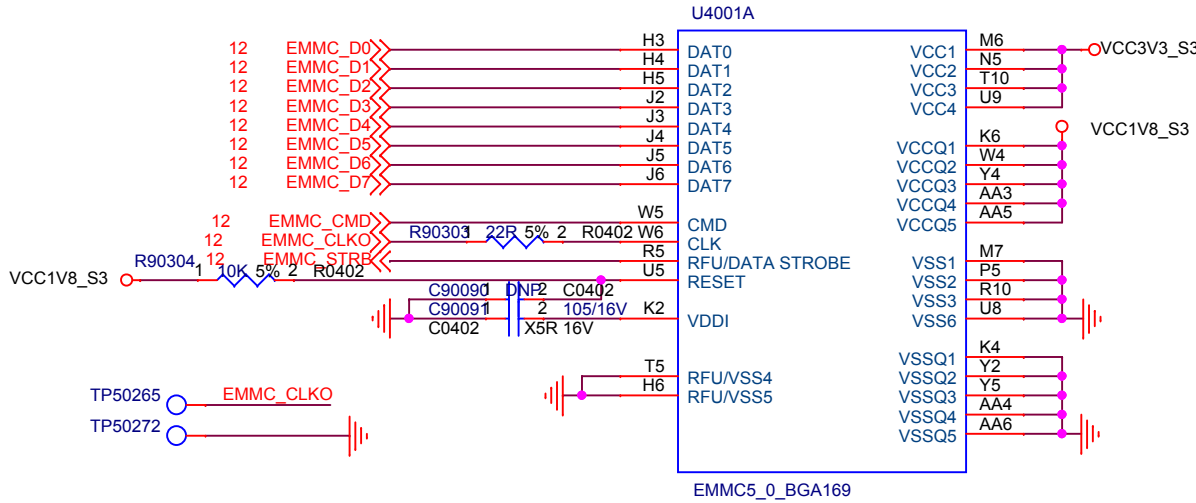
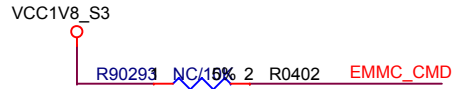

U4001B		EMMC5_0_BGA169	
A4	NC1	P13	NC68
A6	NC2	P14	NC69
A9	NC3	R1	NC70
A11	NC4	R2	NC71
B2	NC5	R3	NC72
B13	NC6	R12	NC73
D1	NC7	R13	NC74
D14	NC8	R14	NC75
H1	NC9	T1	NC76
H2	NC10	T2	NC77
H7	NC11	T3	NC78
H8	NC12	T12	NC79
H9	NC13	T13	NC80
H10	NC14	T14	NC81
H11	NC15	U1	NC82
H12	NC16	U2	NC83
H13	NC17	U3	NC84
H14	NC18	U6	NC85
J1	NC19	U7	RFU10(NC85)
J7	NC20	U10	RFU11(NC86)
J8	NC21	U12	RFU12(NC87)
J9	NC22	U13	NC88
J10	NC23	U14	NC89
J11	NC24	V1	NC90
J12	NC25	V2	NC91
J13	NC26	V3	NC92
J14	NC27	V12	NC93
K1	NC28	V13	NC94
K3	NC29	V14	NC95
K5	NC30	W1	NC96
K7	NC31	W2	NC97
K8	NC32	W3	NC98
K9	NC33	W7	NC99
K10	NC34	W8	NC100
K11	NC35	W9	NC101
K12	NC36	W10	NC102
K13	NC37	W11	NC103
K14	NC38	W12	NC104
L1	NC39	W13	NC105
L2	NC40	W14	NC106
L3	NC41	Y1	NC107
L4	NC42	Y3	NC109
L12	NC43	Y6	NC110
L13	NC44	Y7	NC111
L14	NC45	Y8	NC112
M1	NC46	Y9	NC113
M2	NC47	Y10	NC114
M3	NC48	Y11	NC115
M12	NC49	Y12	NC116
M13	NC50	Y13	NC117
M14	NC51	Y14	NC118
M5	NC52	AA1	NC119
M8	RFU3(NC52)	AA2	NC120
M9	RFU4(NC53)	AA7	NC121
M10	RFU5(NC54)	AA8	RFU13(NC121)
N1	RFU6(NC55)	AA9	NC122
N2	NC56	AA10	NC123
N3	NC57	AA11	RFU14(NC124)
N10	NC58	AA12	NC125
N12	RFU7(NC59)	AA13	NC126
N13	NC60	AA14	NC127
N14	NC61	AE1	NC128
N15	NC62	AE14	NC129
P1	NC63	AG2	NC130
P2	NC64	AG13	NC131
P3	NC65	AH4	NC132
P10	RFU8(NC65)	AH6	NC133
P12	RFU9(NC66)	AH9	NC134
	NC67	AH11	NC135
			NC136

Xunlong Software

Design Name			
Orangepi-RK3399			
Size	Page Name	Rev	
A4	eMMC	1.4	
Date:	Tuesday, December 12, 2017	Sheet	18 of 30

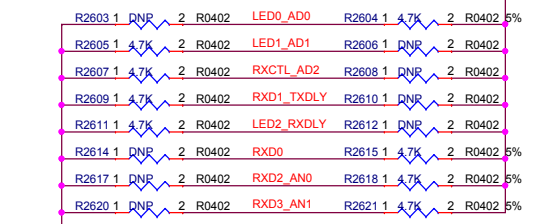
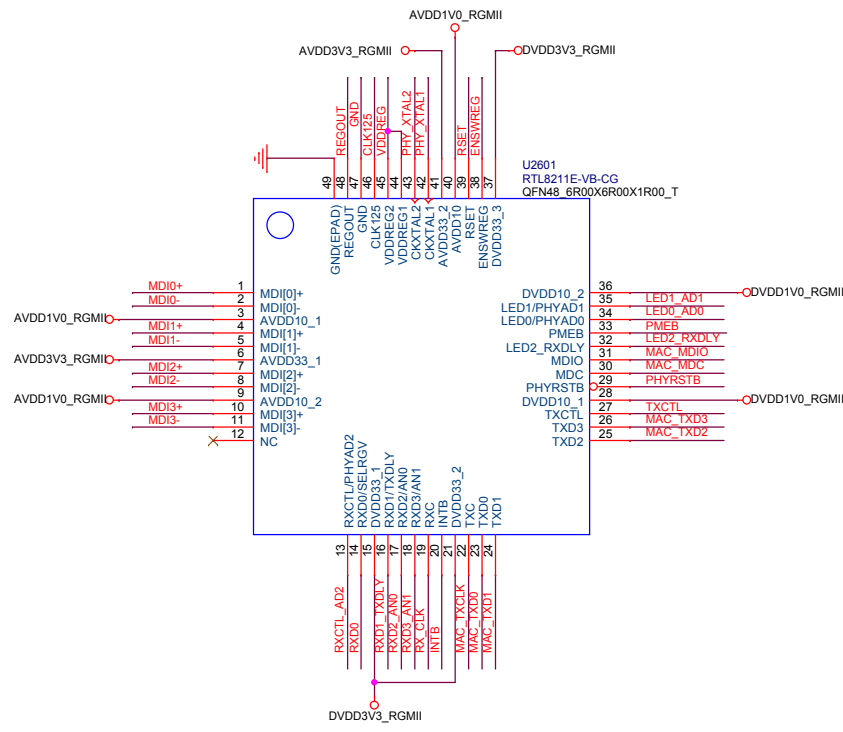

**R61,R62: Config for all capability**  
**R51,R54,R148: PHY Address=001(RTL8211E)**  
**R64,R50: Without TX/RX Delay**

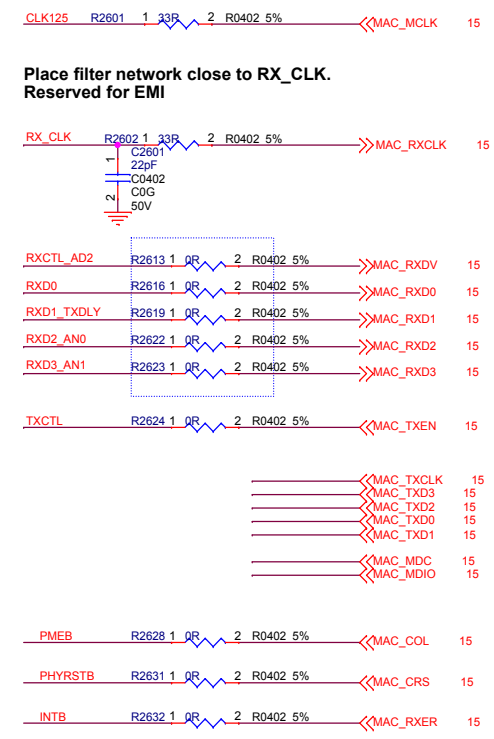
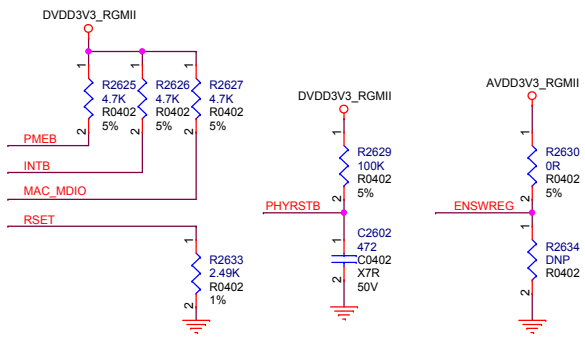

**Place filter network close to RX\_CLK.**  
**Reserved for EMI**

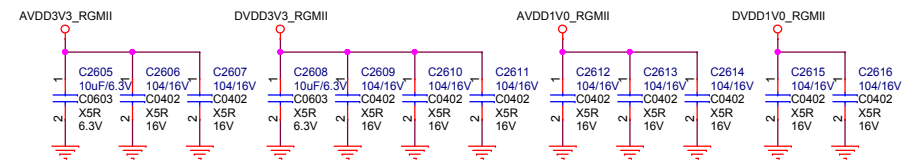
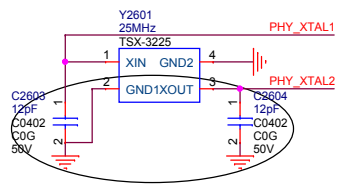

**Note 1: The Trace length between L1 and PHY's Pin48 must be within 0.5 cm. C35 and C36 to L1 must be within 0.5cm. Any inductance or bead except for L1 is not allowed on the path from REGOUT to DVDD10/AVDD10.**

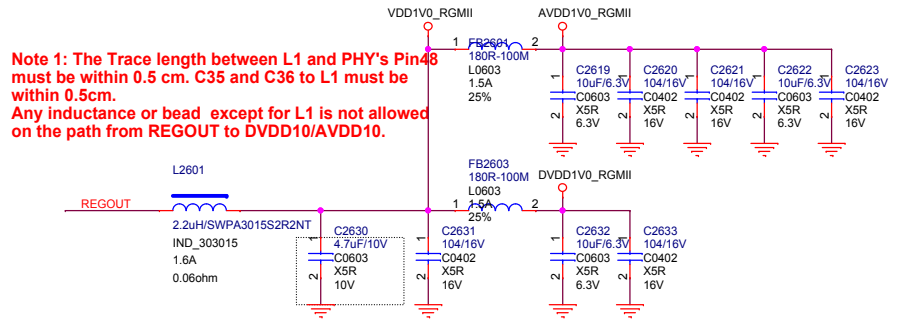

**Note 2: The Trace length from C56, C57 to Pin 44,45(VDDREG) must be within 0.5 cm. The trace width from AVDD33 to Pin 44,45 should>40mils**

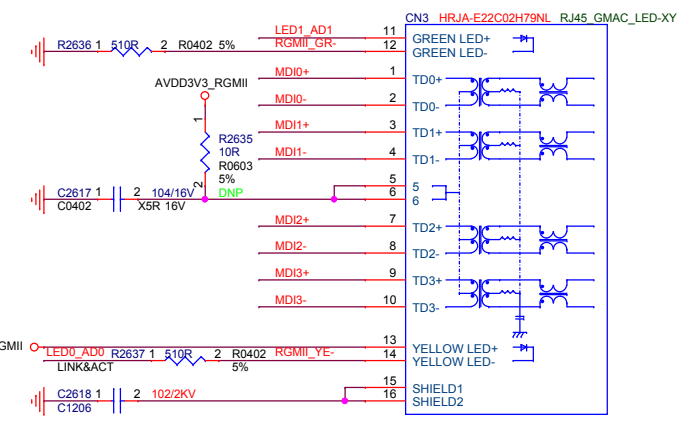
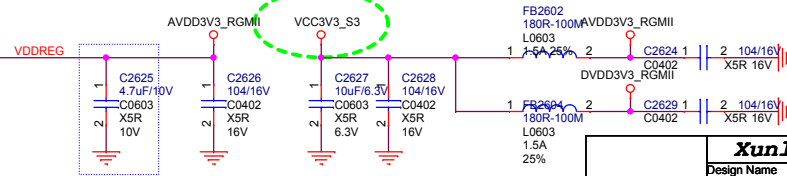

# HDMI Port

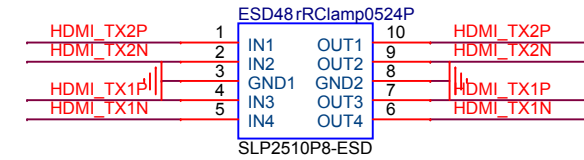
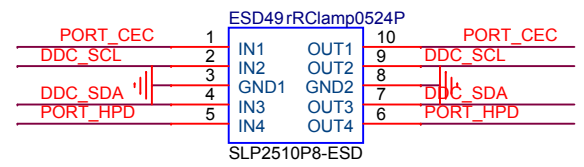
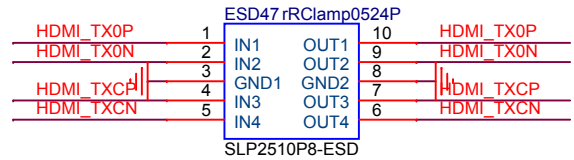
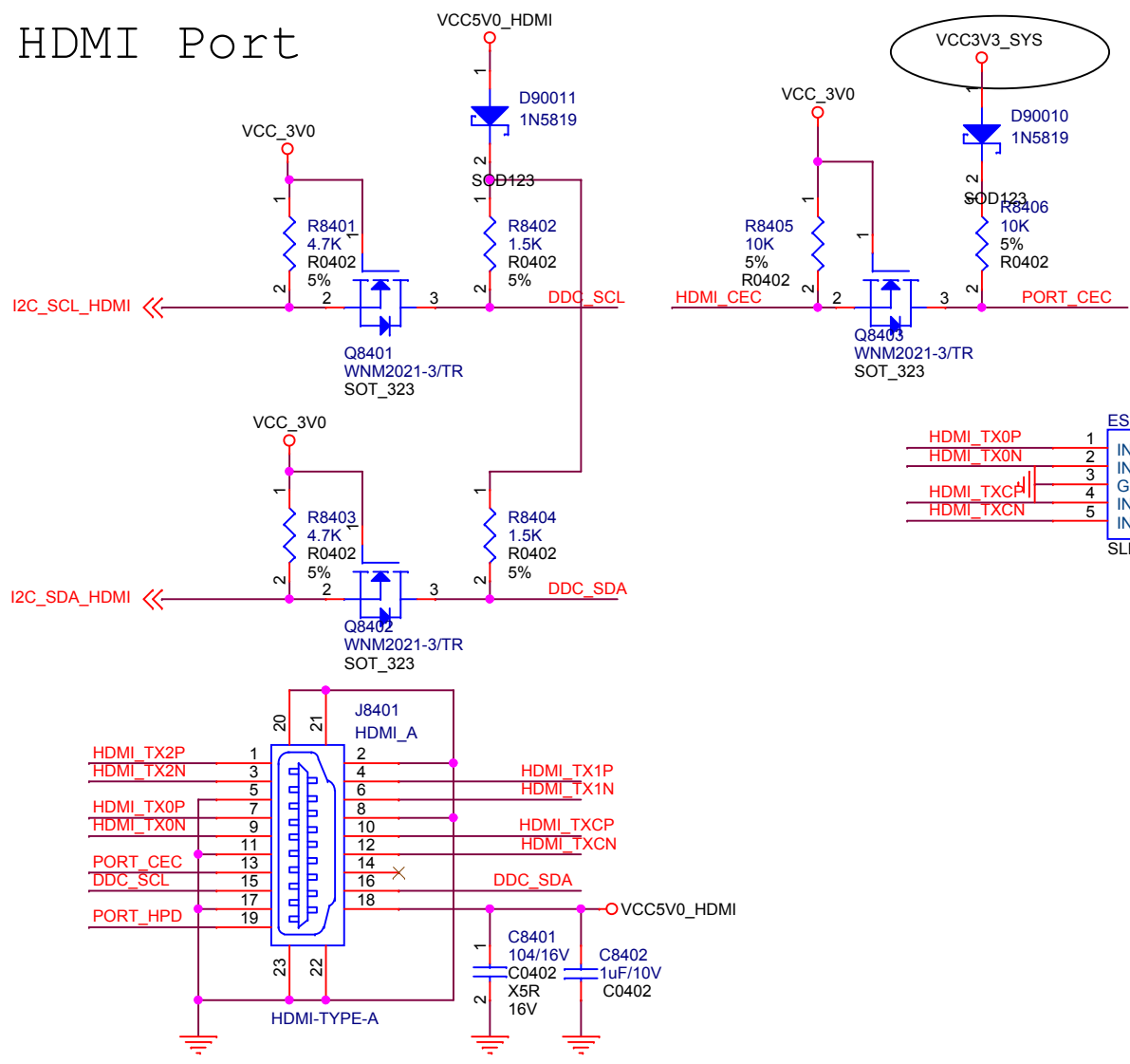

- HDMI\_TX0P 17
- HDMI\_TX0N 17
- HDMI\_TX1P 17
- HDMI\_TX1N 17
- HDMI\_TX2P 17
- HDMI\_TX2N 17
- HDMI\_TXCP 17
- HDMI\_TXCN 17
- HDMI\_CEC 15
- PORT\_HPDI 17
- I2C\_SCL\_HDMI 15,20
- I2C\_SDA\_HDMI 15,20

<b>Xunlong Software</b>		
Design Name		
<b>Orangepi-RK3399</b>		
Size	Page Name	Rev
A4	<b>HDMI</b>	1.4
Date:	Tuesday, December 12, 2017	Sheet 20 of 30

# eDP Panel

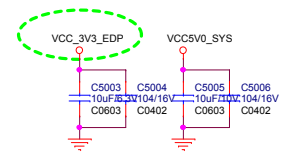
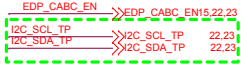
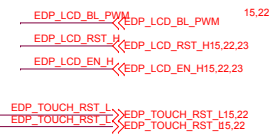
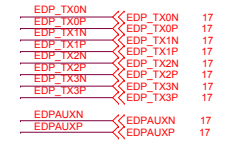
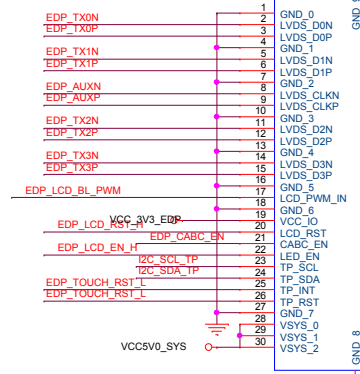
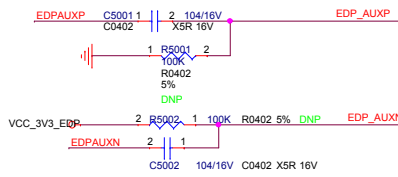
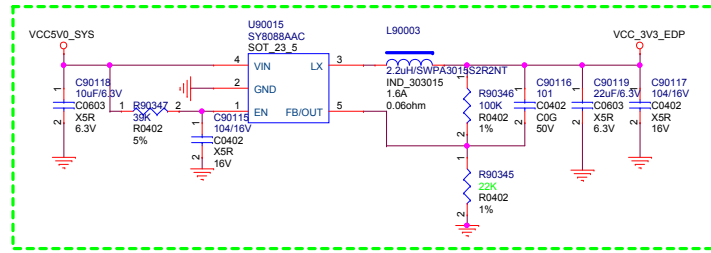

注释: J4701是LCD1屏接口, 使用MIPI\_TX0输出, 调试过8寸和10寸屏。

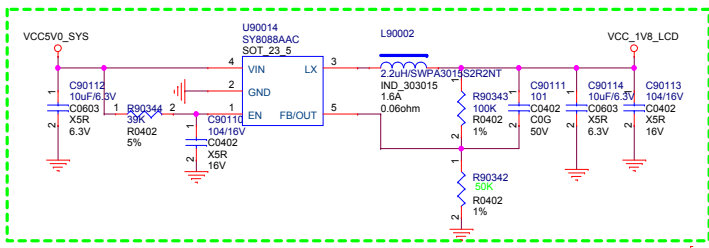

注释: J4702是LCD2屏接口, 使用MIPI\_TX1/RX1输出, 没有调试过。

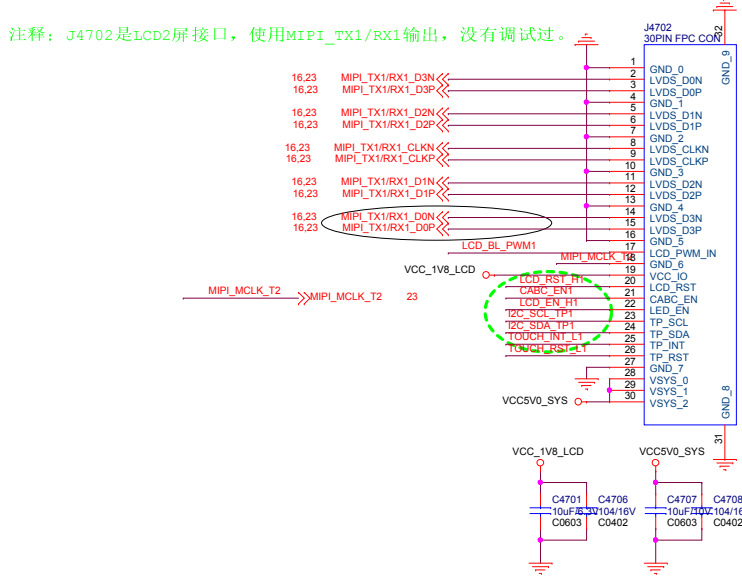
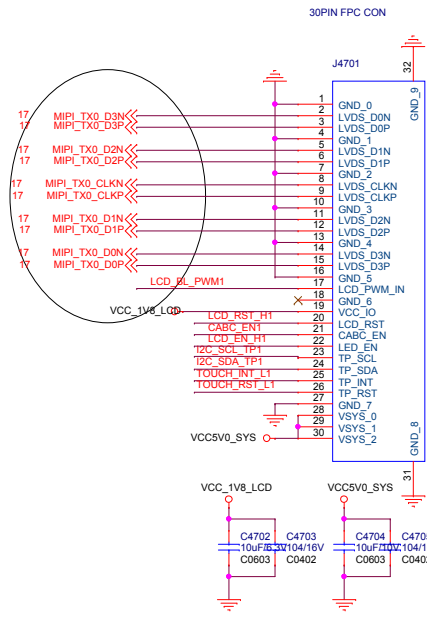

将vcc1v8\_s3改成vcc\_1v8\_lcd

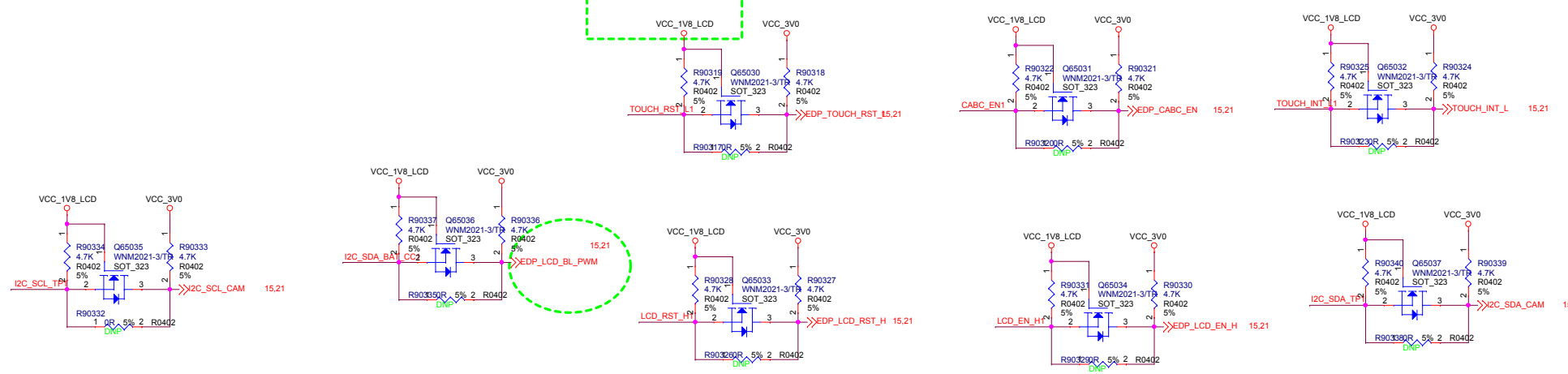

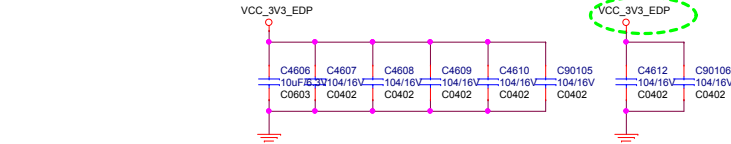
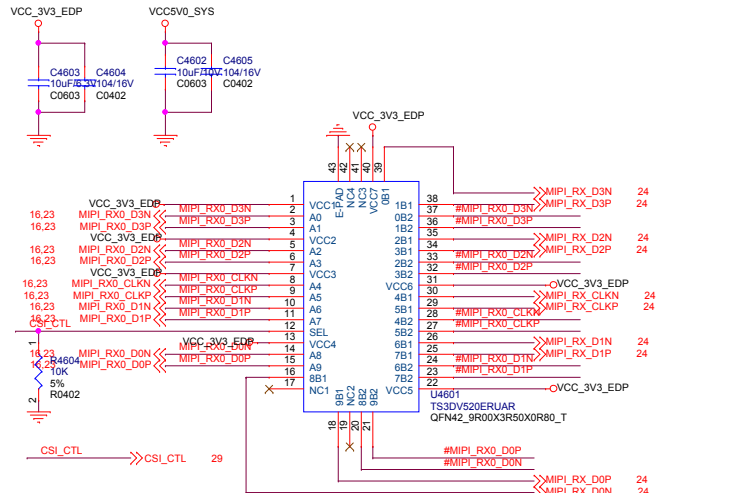
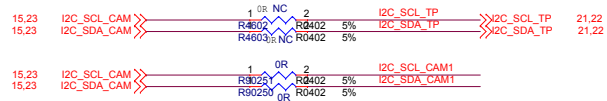
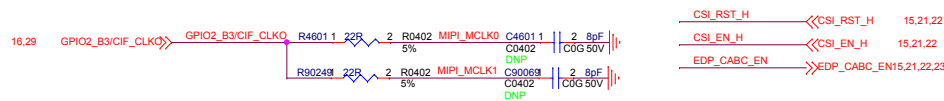

- 16.22 MIPI\_TX1/RX1\_D0P <<
- 16.22 MIPI\_TX1/RX1\_D0N <<
- 16.22 MIPI\_TX1/RX1\_D1P <<
- 16.22 MIPI\_TX1/RX1\_D1N <<
- 16.22 MIPI\_TX1/RX1\_CLKP <<
- 16.22 MIPI\_TX1/RX1\_CLKN <<
- 16.22 MIPI\_TX1/RX1\_D2P <<
- 16.22 MIPI\_TX1/RX1\_D2N <<
- 16.22 MIPI\_TX1/RX1\_D3P <<
- 16.22 MIPI\_TX1/RX1\_D3N <<

注释: J4601是CAMERA1接口, 使用MIPI\_RX0输出, 没有调试过。

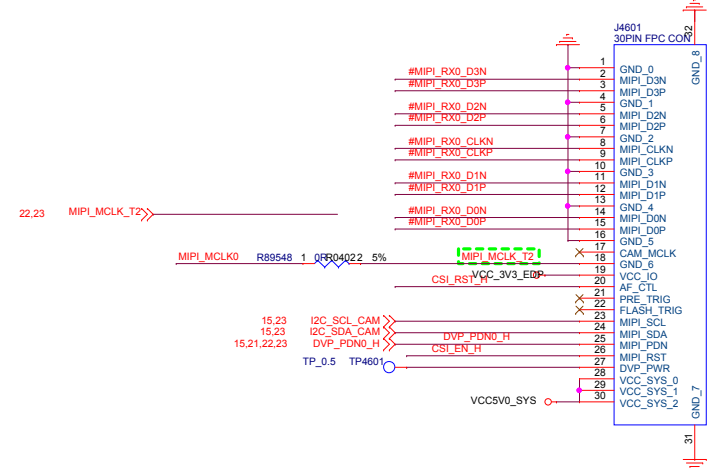

注释: J90005是CAMERA2接口, 使用MIPI\_RX1输出, 调试过OV13850。

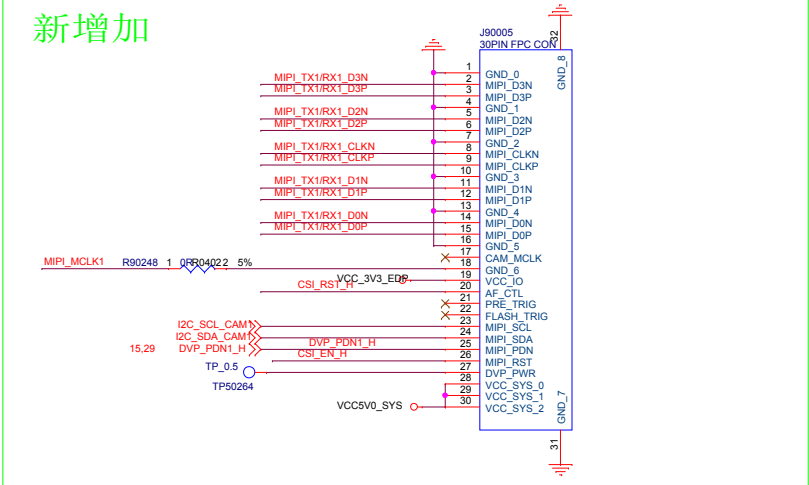

新增加

0.5mm Pitch 30Pin FPC连接器

5

4

3

2

1

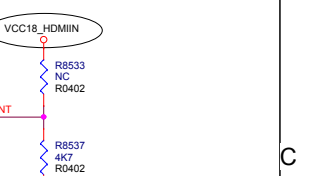
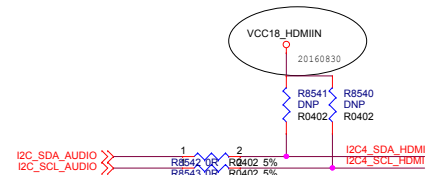
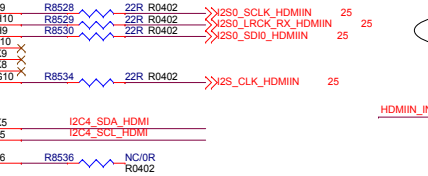
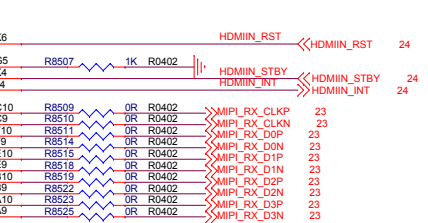
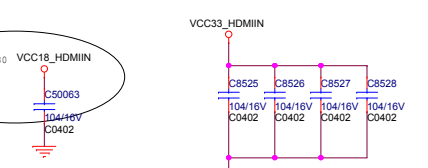
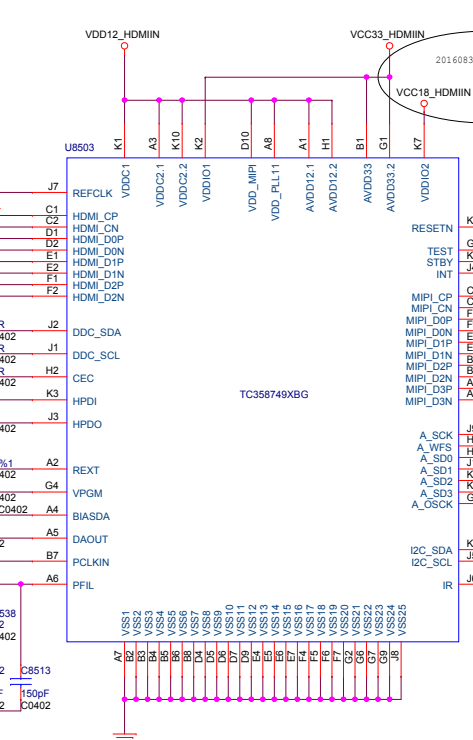
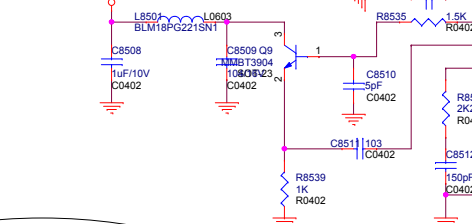
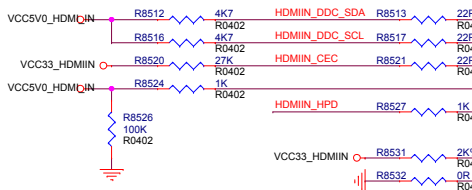
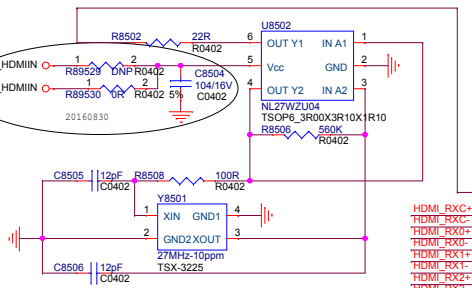
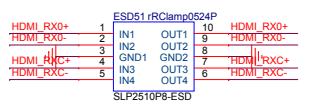
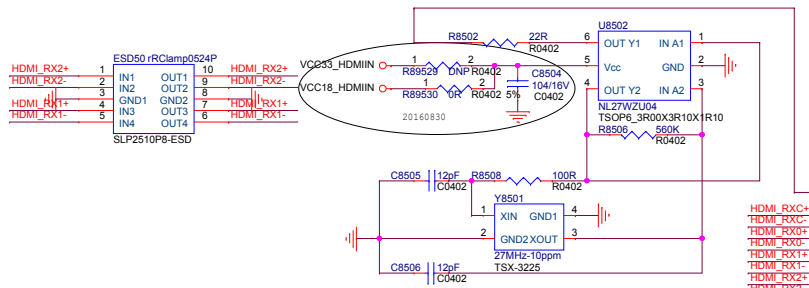

D

D

C

C

B

B

A

A

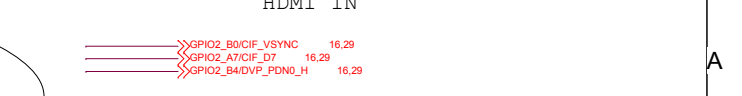
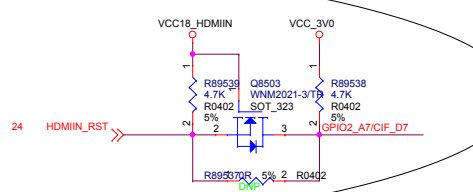
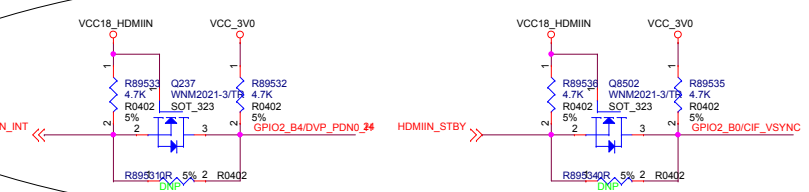
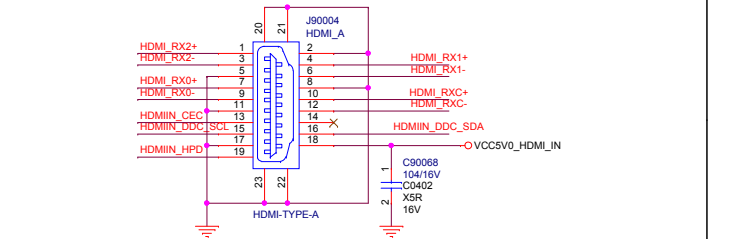
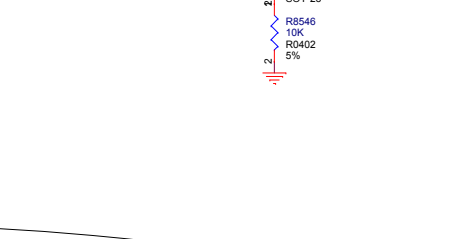
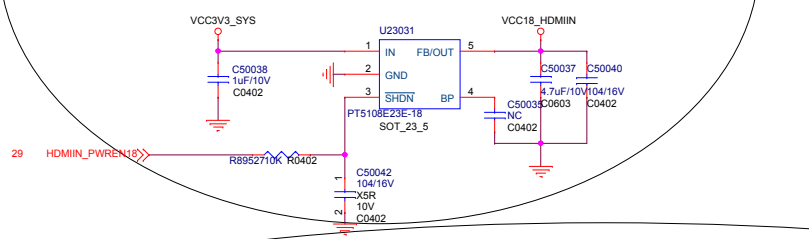
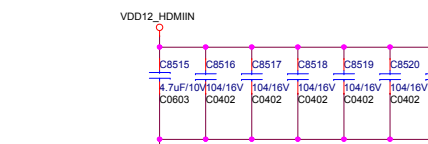
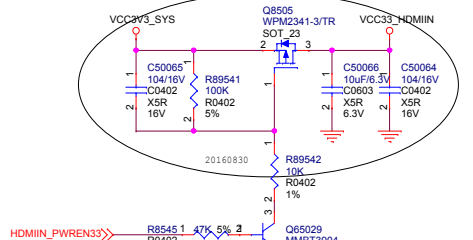
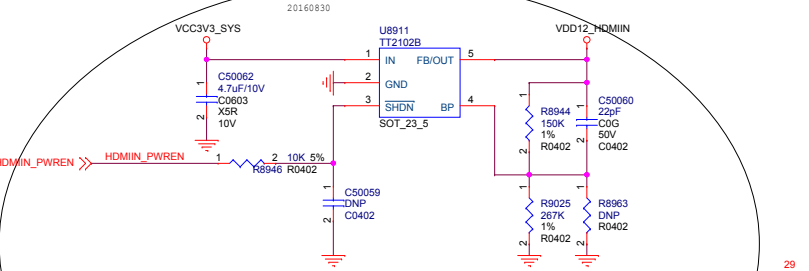

<b>Xunlong Software</b>			
Design Name		<b>OrangePi-RK3399</b>	
Size	Page Name	<b>HDMI INPUT</b>	
Custom	Number	<b>1.4</b>	
Date:	Tuesday, December 12, 2017	Sheet	24 of 30



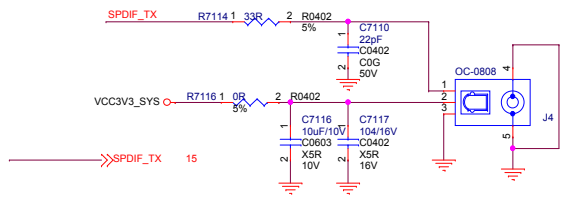
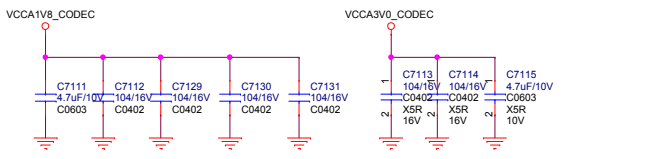
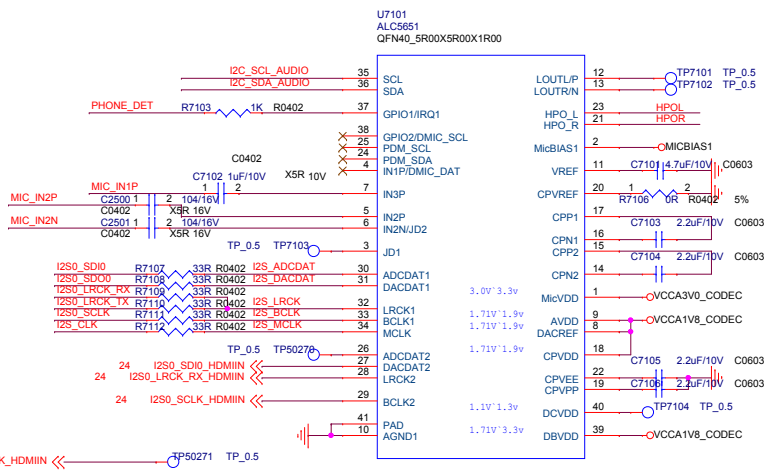

MIC ARRAY

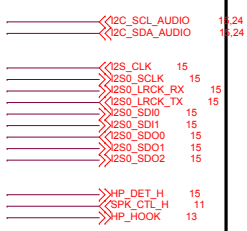

MIC

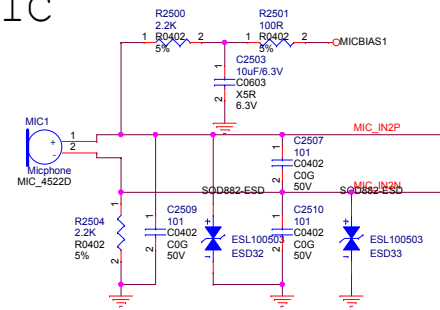

SPEAKER

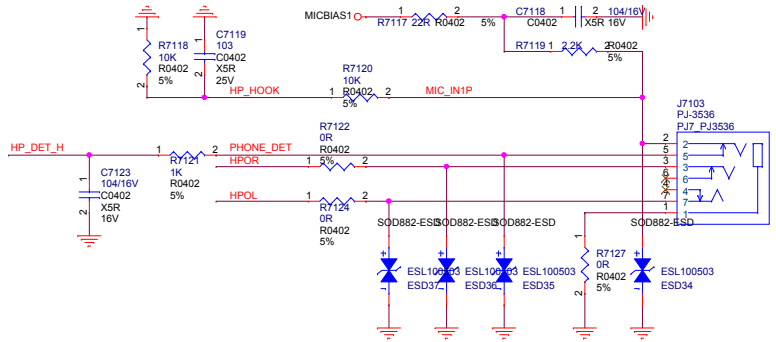
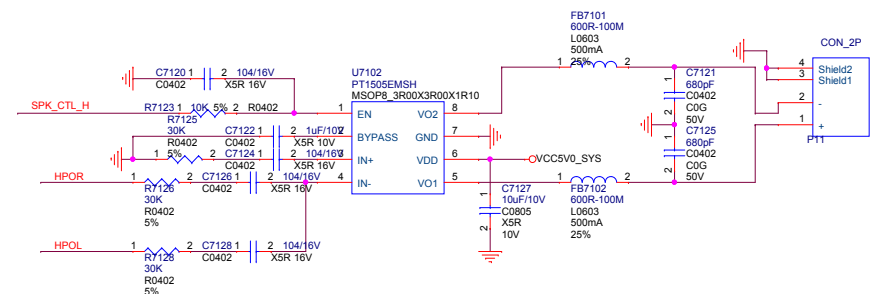

# WIFI/WIFI ac/BT MODULE

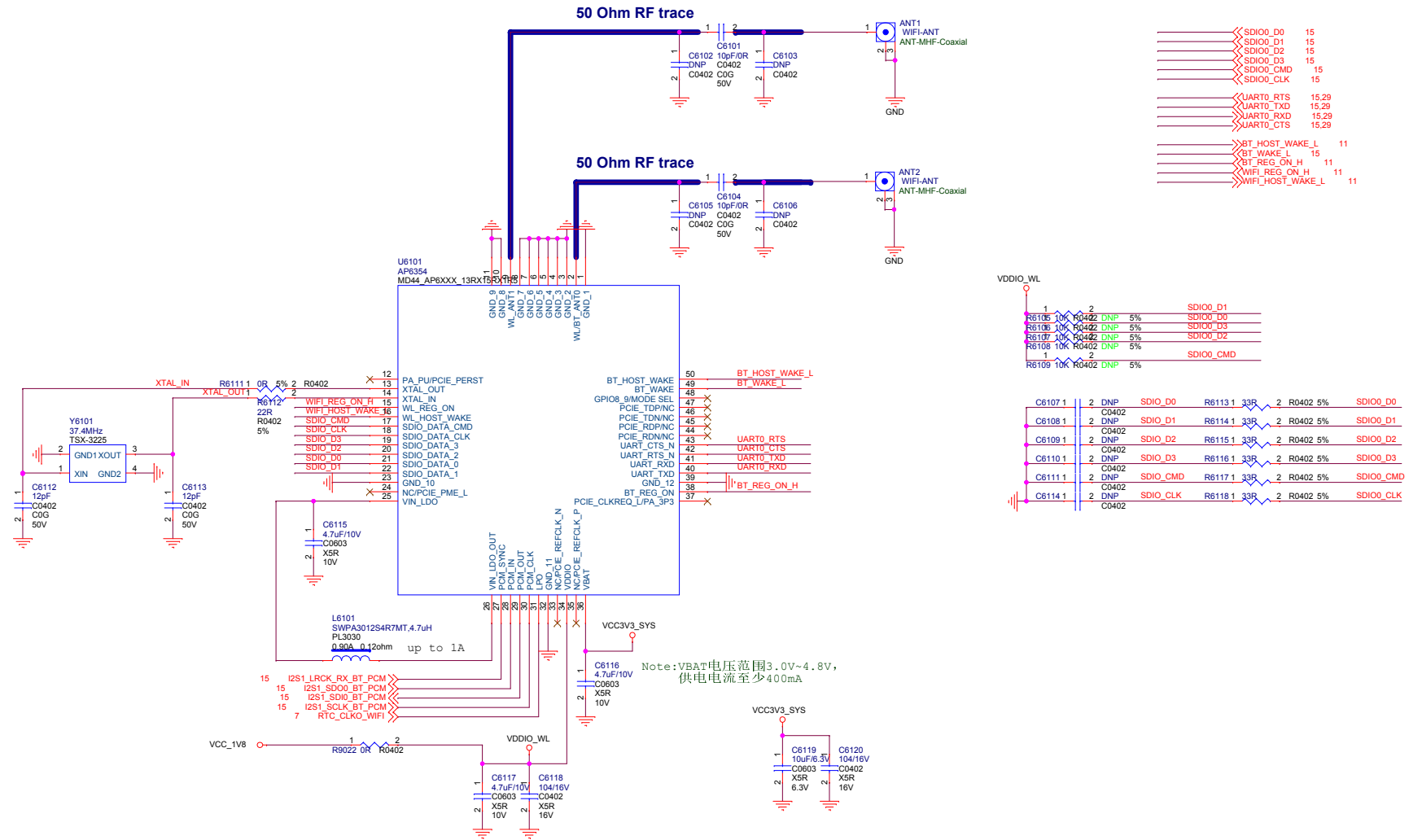

- >>> SDIO0\_D0 15
- >>> SDIO0\_D1 15
- >>> SDIO0\_D2 15
- >>> SDIO0\_D3 15
- >>> SDIO0\_CMD 15
- >>> SDIO0\_CLK 15
- >>> UART0\_RTS 15,29
- >>> UART0\_TXD 15,29
- >>> UART0\_RXD 15,29
- >>> UART0\_CTS 15,29
- >>> BT\_HOST\_WAKE\_L 11
- >>> BT\_WAKE\_L 15
- >>> BT\_REG\_ON\_H 11
- >>> WIFI\_REG\_ON\_H 11
- >>> WIFI\_HOST\_WAKE\_L 11

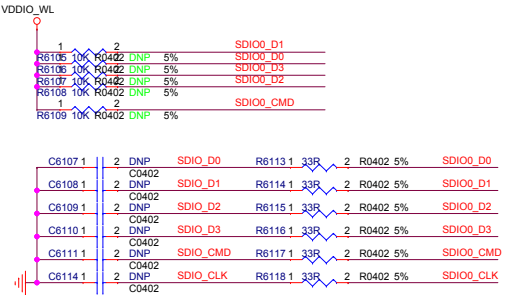

Note: VBAT电压范围3.0V~4.8V,  
供电电流至少400mA

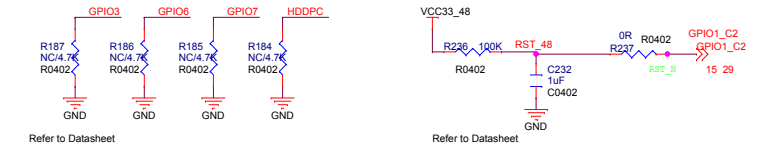
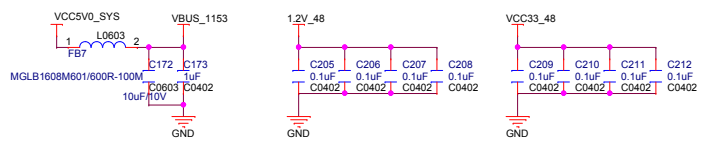
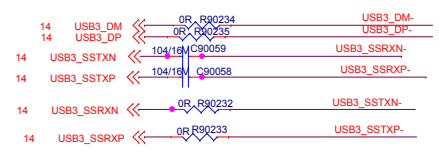
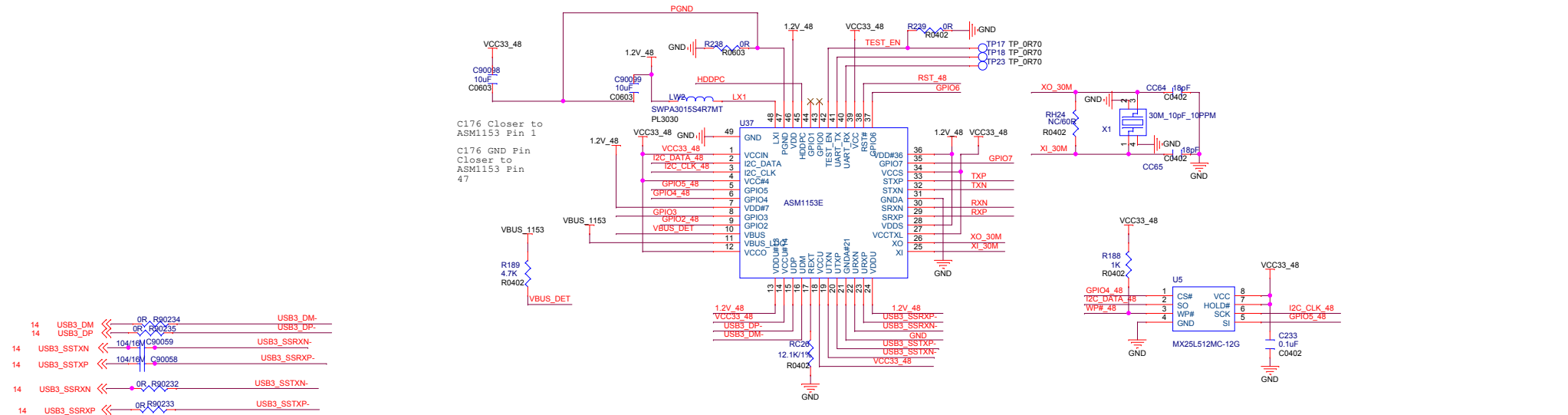

Refer to Datasheet

GPIO7 (CLK_SEL1)	GPIO3 (CLK_SEL0)	
0	0	25MHz
0	1	20MHz
1	1	30MHz

Refer to Datasheet

GPIO6	SPI_EN#
0	Enable
1	Disable

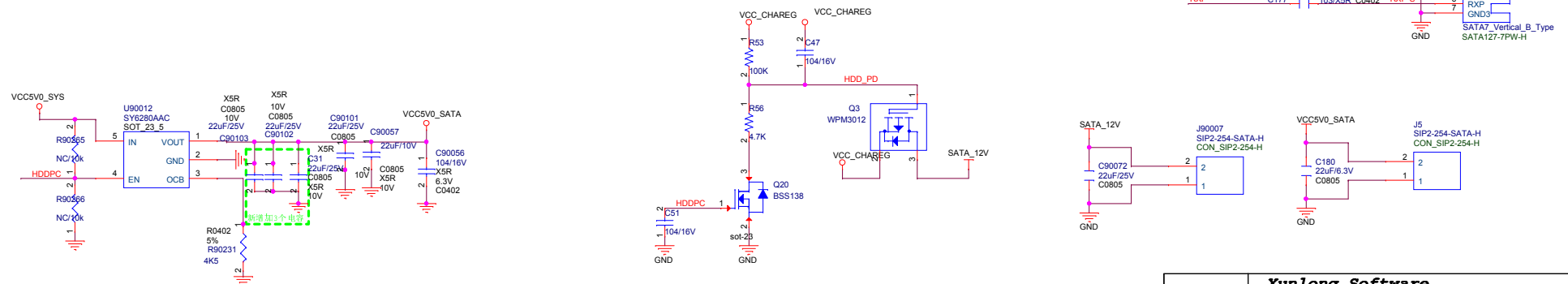
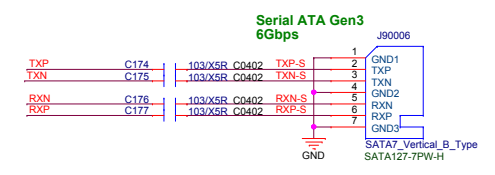
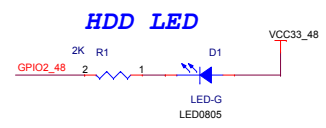



# Compass

# Compass

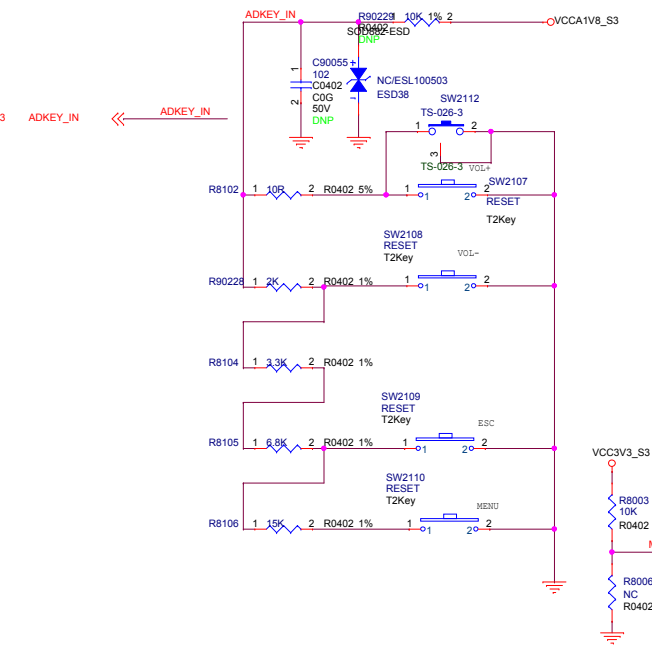

# Gyroscope+G-sensor

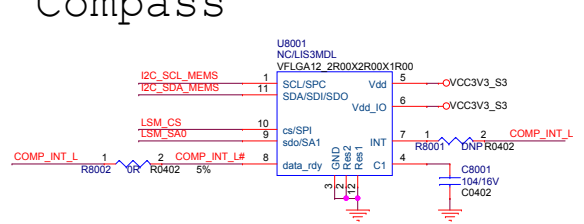
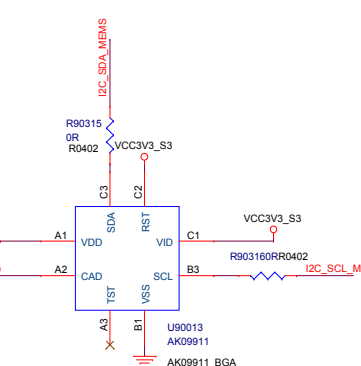
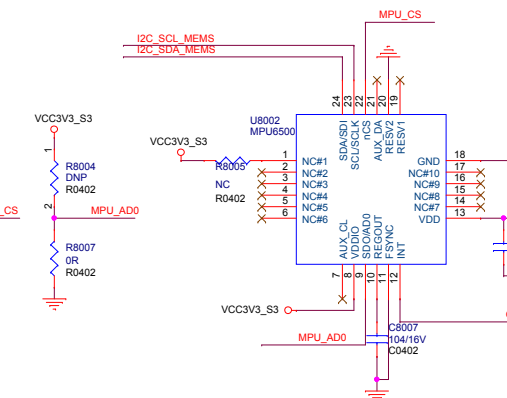

# HALL IC

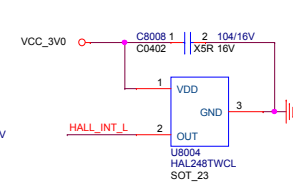

# Gyroscope

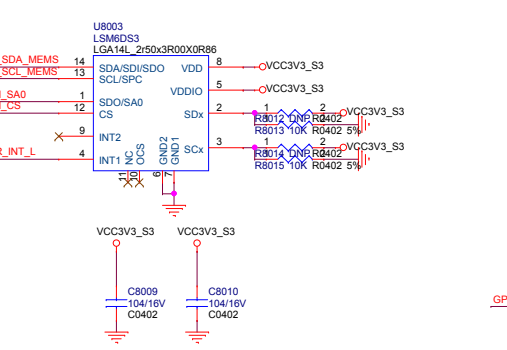

# LIGHT-Sensor

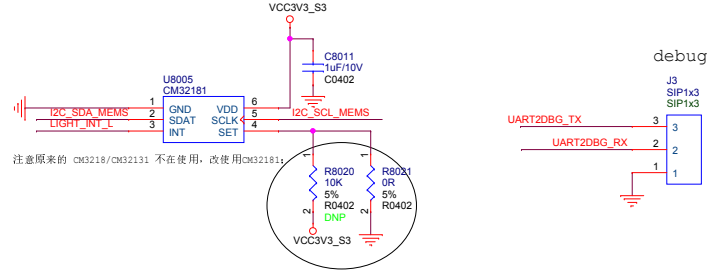

- >>>GPIO2\_A0/CIF\_D0 16
- >>>GPIO2\_A1/CIF\_D1 16
- >>>GPIO2\_A2/CIF\_D2 16
- >>>GPIO2\_A3/CIF\_D3 16
- >>>GPIO2\_A4/CIF\_D4 16
- >>>GPIO2\_A5/CIF\_D5 16
- >>>GPIO2\_A6/CIF\_D6 16
- >>>GPIO2\_A7/CIF\_D7 16,24
- >>>GPIO2\_B0/CIF\_VSYNC 16,24
- >>>GPIO2\_B1/CIF\_HREF 16
- >>>GPIO2\_B2/CIF\_CLKI 16
- >>>GPIO2\_B3/CIF\_CLKO 16,23
- >>>GPIO2\_B4/DVP\_PDN0\_H 16,24

- <<<I2C\_SDA\_MEMS <<<I2C\_SDA\_MEMS 15
- <<<I2C\_SCL\_MEMS <<<I2C\_SCL\_MEMS 15
- <<<GSENSOR\_INT\_L <<<GSENSOR\_INT\_L 15
- <<<GYR\_INT\_L <<<GYR\_INT\_L 15
- <<<COMP\_INT\_L <<<COMP\_INT\_L 15
- <<<HALL\_INT\_L <<<HALL\_INT\_L 11
- <<<LIGHT\_INT\_L <<<LIGHT\_INT\_L 15

- 15 UART2DBG\_RX <<<UART2DBG\_RX
- 15 UART2DBG\_TX <<<UART2DBG\_TX

- <<<SPI1\_RXD 15
- <<<SPI1\_TXD 15
- <<<SPI1\_CLK 15
- <<<SPI1\_CSv0 15

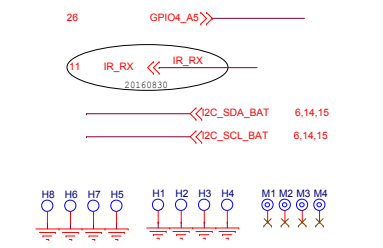

# IR RECEIVE

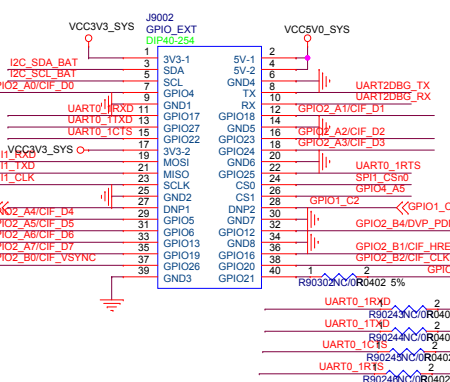
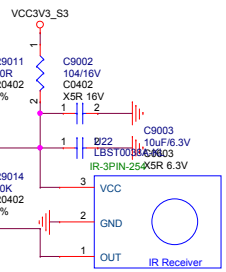

- GPIO2\_A5/CIF\_D5 1 2 R8954 10K 5% <<<HDMIN\_PWREN3 24
- GPIO2\_B1/CIF\_HREF 1 2 R8905 10K 5% <<<HDMIN\_PWREN18 24
- GPIO2\_A6/CIF\_D6 1 2 R8001 10K 5% <<<HDMIN\_PWREN 24
- GPIO2\_B2/CIF\_CLKI 1 2 R9006 10K 5% <<<CSLCTL 23

- GPIO2\_A2/CIF\_D2 1 2 R9024 10K 5%
- GPIO2\_A3/CIF\_D3 1 2 R9025 10K 5%
- GPIO2\_A4/CIF\_D4 1 2 R9026 10K 5%
- GPIO2\_B3/CIF\_CLKO 1 2 R9027 10K 5%

Func1	Func2	Func3
GPIO2_A0/CIF_D0		I2C2_SDA
GPIO2_A1/CIF_D1		I2C2_SCL
GPIO2_A2/CIF_D2		I2C2_SDA
GPIO2_B0/CIF_VSYNC		I2C1_SCL
GPIO2_B1/CIF_HREF	SP12_RXD	I2C6_SDA
GPIO2_B2/CIF_CLKI	SP12_TXD	I2C6_SCL
GPIO2_B3/CIF_CLKO	SP12_CLK	
GPIO2_B4/DVP_PDN0_H	SP12_CS0	

13,14,15 VCC5V0\_HOST1\_EK  
 14 HOST1\_DM SOC-DM1  
 14 HOST1\_DP SOC-DP1

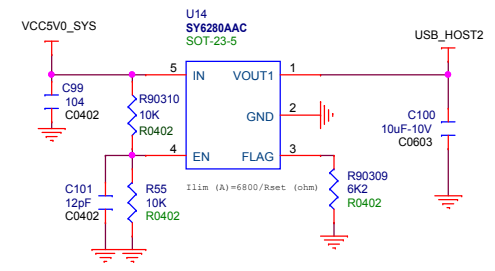
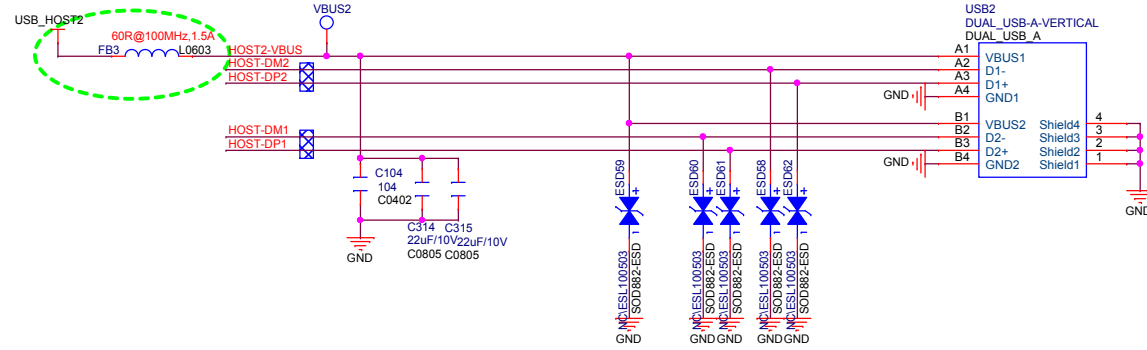
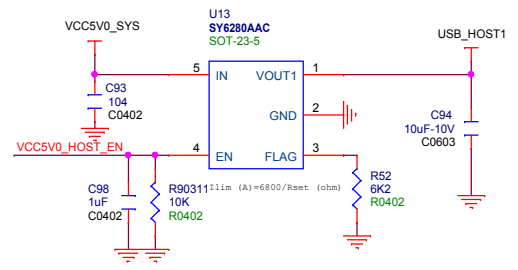
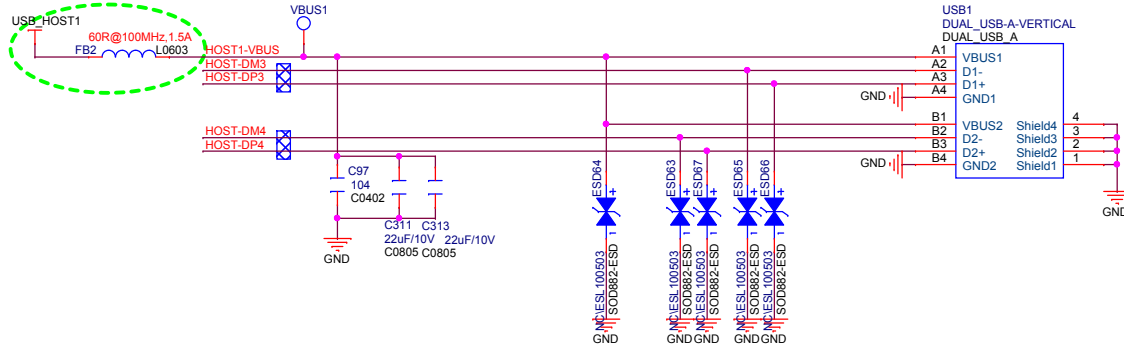
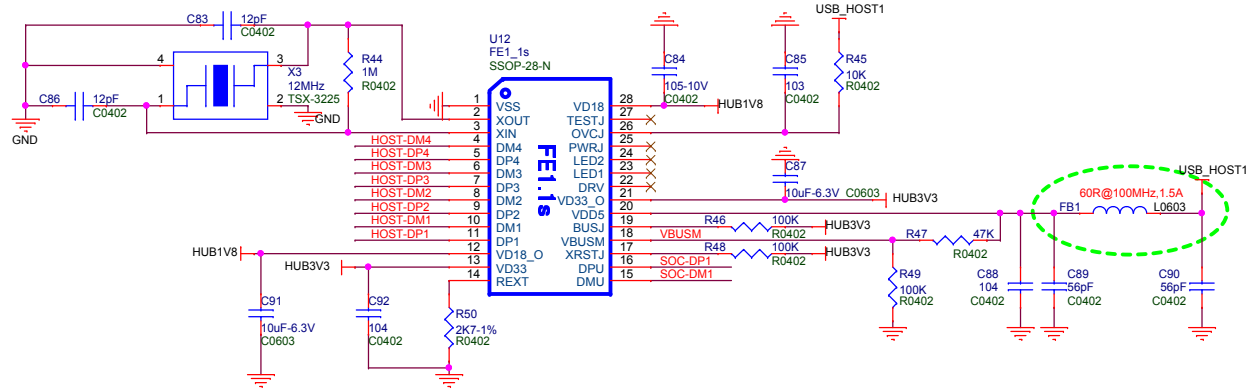

<b>Xunlong Software</b>		
Design Name		
<b>Orangepi-RK3399</b>		
Size	Page Name	Rev
A3	<b>USB2.0HUB</b>	1.4
Date:	Tuesday, December 12, 2017	Sheet 30 of 30