



e-WriterPro User's Guide

Revision: V1.00 Date: August 08, 2019

www.holtek.com

How to use this guide

Chapter 1 – “Introduction to the Writer and Installation” introduces the installation of the writer and the programming software HOPE3000. Users who use the writer for the first time need to read this chapter carefully in order to set up the programming environment successfully.

After installation, refer to the commonly used cases provided in Chapter 2 – “Quick Start” for writer usage. Users would easily complete the required programming operations by following the steps described in each case.

Chapter 3 – “Introduction to the HOPE3000 Main Functions” and Chapter 4 – “Introduction to the HOPE3000 Smart Programming Function”, provide a comprehensive introduction of the HOPE3000 UI, functions and important considerations. To understand the full functions of the HOPE3000, read these two chapters in detail.

In addition to using the HOPE3000 by Windows UI, users can also operate the writer by the command method in the program “Command Prompt” under MS Windows. This is introduced in Chapter 5 – “Introduction to HOPE3000 –DOS Command Mode”.

Appendix A – “System and Writer Error Messages” lists all the error messages appeared when using the HOPE3000 and writer, the explanations of these messages and the basic error detect methods to these errors.

Appendix B – “Writer LEDs and Status” explains the status definition of three LEDs on the writer. Appendix C – “e-WriterPro ICP Pin Definitions and ICP Considerations” lists the programming pin definitions and considerations. Appendix D – “e-WriterPro CN3 Pin Definitions” lists the CN3 pin definitions providing a reference for users who need to use external digital signals to control the e-WriterPro programming.

Table of Contents

Chapter 1 Introduction to the Writer and Installation.....	5
Installation	5
Hardware Configuration	9
Chapter 2 Quick Start	11
Preparation before Programming.....	11
Case. 1 – Programming an MCU	11
Case. 2 – Auto Programming	13
Case. 3 – IC Partial Programming	15
Case. 4 – Programming Serial Numbers or Other Specified Data.....	18
Case. 5 – Standalone Programming – Off-Line Mode	20
Case. 6 – Reading Data from an MCU – Without using a Programming File	20
Case. 7 – Executing the Programming Operations by Command Method	22
Case. 8 – Updating the Writer Firmware via a PC	23
Case. 9 – Registering and Activating the Writer.....	26
Case. 10 – Using external digital signals to control e-WriterPro Programming	29
Case. 11 – Using the e-WriterPro In-circuit Programming Function.....	31
Case. 12 – Setting a Limit on the Programming Times.....	31
Chapter 3 Introduction to the HOPE3000 Main Functions	33
Menu Section	34
ROM Data Section	37
Message Box and Other Information Section	38
IC Information Section.....	38
Programming Operations and Smart Programming Section	39
Other Functions.....	40
Chapter 4 Introduction to the HOPE3000 Smart Programming Function	41
IC Information Section.....	42
Operating Commands Section	42
Programming Setting Section	43
Message and Other Information Section.....	44
Programming Range Setting Window.....	45
User Specified Data Setting Window	47
Chapter 5 Introduction to HOPE3000 – DOS Command Mode.....	50
Features	50
Command List.....	50
Examples	56
Appendix A System and Writer Error Messages.....	57
System Error Messages.....	57
Writer Error Messages	59
Appendix B Writer LEDs and Status.....	61

Appendix C e-WriterPro ICP Pin Definitions and ICP Considerations..... 62
 e-WriterPro ICP Pin Definitions.....62
 ICP Considerations67

Appendix D e-WriterPro CN3 Pin Definitions 68

Chapter 1 Introduction to the Writer and Installation

The e-WriterPro is a writer designed for programming the Holtek all series of MCUs. The writer can be used to write program or data to all the OTP/Flash MCUs designed by Holtek. The writer's special features are in its small, light and handy palm size outline. Installation is simple and is easy to use.

This writer supports an On-Line Programming Mode that needs to connect with a PC and an Off-Line Programming Mode that does not require a PC connection. In the Off-Line Mode, after downloading the programming data to the writer using the HOPE3000 on a PC, the writer can be operated without a PC connection. In the On-Line Mode, a USB cable is required to connect to the PC and the writer after which the writer can be operated using the HOPE3000.

As Holtek provides different MCU package types, different programming sockets, i.g. e-Socket, are also supplied for programming different MCU package types.

Installation

System Requirement

To use the writer the following device and system are required:

- Power: the external power in Off-Line Mode is depicted as table 1-1

Connector	Writer e-WriterPro	Remark
USB Connector	Supported	Using a power adapter with 5V output voltage and at least 500mA output current. It is suggested to use the power adapter supplied by Holtek.

Table 1-1

- Correct programming socket
- PC with a USB port for On-Line Mode
- MS Windows 2000/XP/7/10 or compatible window operating system for On-Line Mode
- HOPE3000 software for On-Line Mode

Note: Programming sockets are consumables, it is suggested to maintain and update them regularly.

Package Contents



Fig. 1-1

Item	Content Name	Count
1	e-WriterPro	1
2	USB Cable	1
3	5V USB Power Adapter	1
4	1.5M Ground Wire	1
5	Flat-Cable double-head 2×6 Pin Connector (25cm)	1
6	Screws (with G15 ground terminal)	1
7	Important Message Card	1

Table 1-2

Hardware Installation

Connect the e-WriterPro to the PC USB port using the USB cable, as shown in Fig. 1-2.

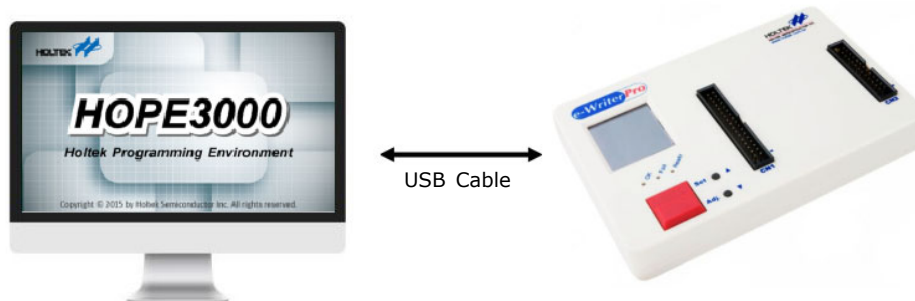

Fig. 1-2

Software Installation

- Step 1
Execute the HOPE3000 installing program “HOPE3000V3.27.5Build20190624Install”. As the version and release date of the supplied software may be different from this, use the latest version.
- Step 2
Installation Welcome Window (Fig. 1-3), click the Next button.

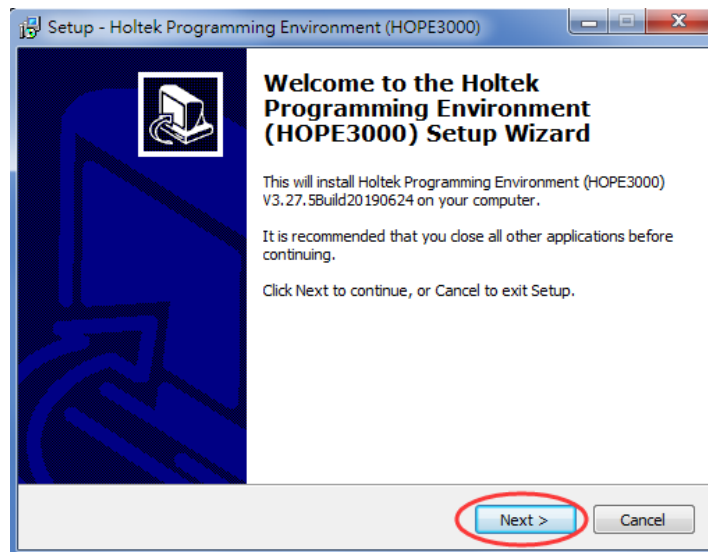

Fig. 1-3

- Step 3
Specify the HOPE3000 path (Fig. 1-4). It is suggested to use the default path, then click the Next button.

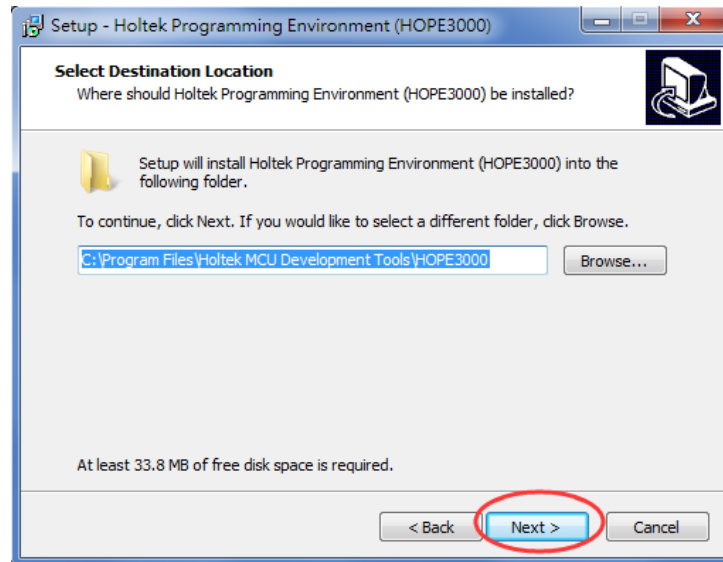

Fig. 1-4

- Step 4
Specify the path of the program's shortcuts (Fig. 1-5). It is suggested to use the default path, then click the Next button.

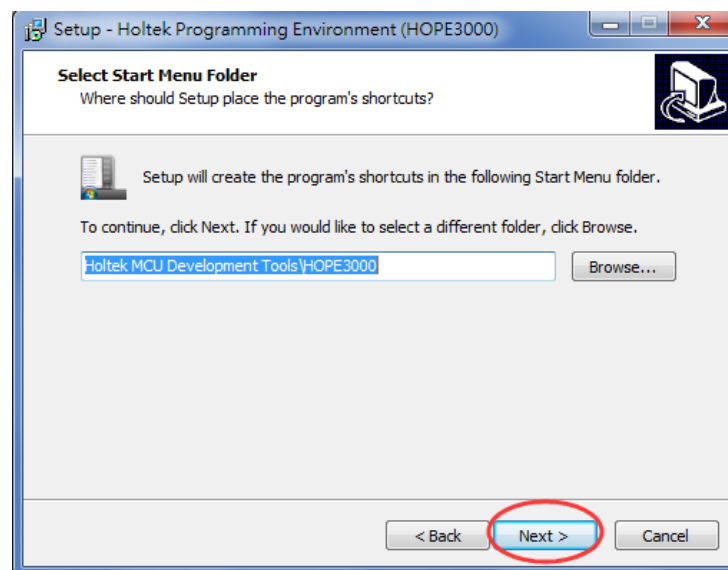

Fig. 1-5

- Step 5
Select the option to generate a desktop shortcut (Fig. 1-6). Then click the Next button.

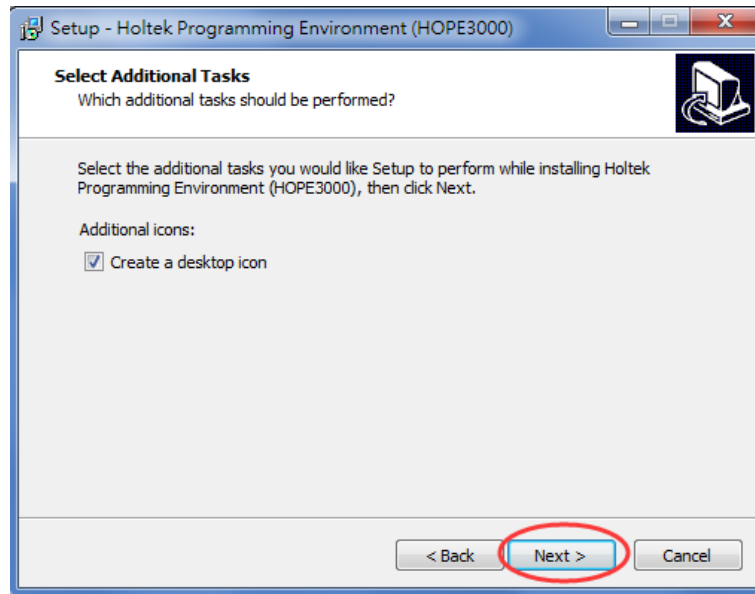

Fig. 1-6

- Step 6
Check the installation details and then click the Install button to start the installation (Fig. 1-7).

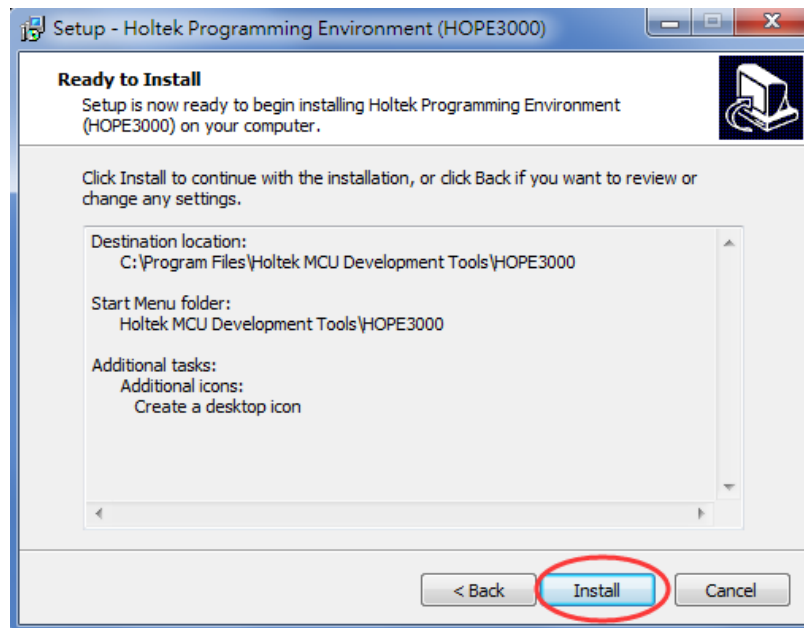

Fig. 1-7

- Step 7
Finish installation. Click the Finish button to exit installation process (Fig. 1-8).

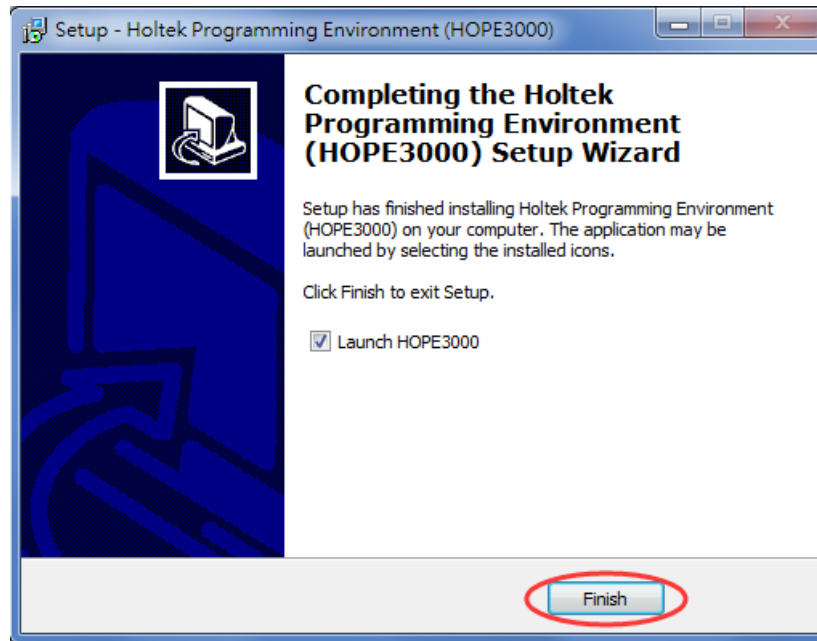

Fig. 1-8

Hardware Configuration

The name of each writer hardware section is shown in Fig. 1-9 (e-WriterPro). Table 1-3 explains each item in this figure.

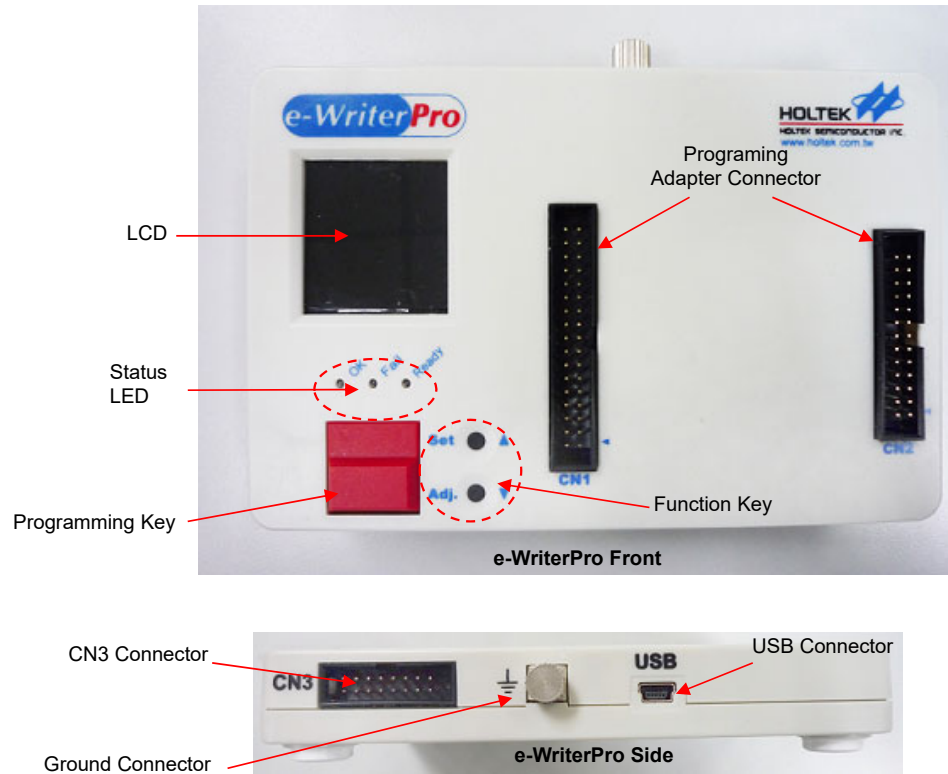

Fig. 1-9

Item	Explanation
Programming Adapter Connector	Programming Pins
OK	Normal Status LED
Ready/Busy	Ready or Busy Status
Fail	Fail Status LED
Programming Key	Off-Line Mode Programming Key
USB Connector	Connect to PC via USB cable (On-Line mode) or Connect to 5V power adapter (Off-Line mode)
LCD	Displays information and to set the writer functions
Function Key	Switch LED pages and to set the writer functions
CN3 Connector	External control signal interface, refer to Appendix D
Ground Connector	Connector for ground wire

Table 1-3

Chapter 2 Quick Start

Preparation before Programming

Before programming the MCU, use the HT-IDE3000 to generate an MCU programming file (.OTP/.MTP/.PND...etc). After this the writer and the HOPE3000 can be used to program the MCU. For the details about the HT-IDE3000, refer to the “HT-IDE3000 User's Guide”.

Connect the writer to the PC and execute the HOPE3000 software. Then follow the steps below to execute MCU programming.

Case. 1 – Programming an MCU

To program an MCU programming file (.OTP/.MTP/.PND) to an MCU using a PC, follow the steps below.

- Step 1

Execute the following command in the HOPE3000: Menu/File/Open, as shown in Fig. 2-1.

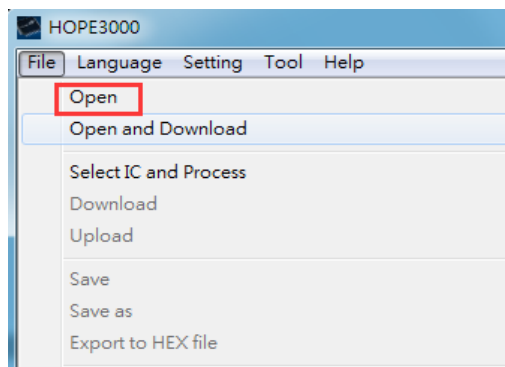

Fig. 2-1

- Step 2

As shown in Fig. 2-2, select the file type (OTP, MTP or PND) firstly (Action 1), then select the file to open (Action 2). Finally click the button of Action 3.

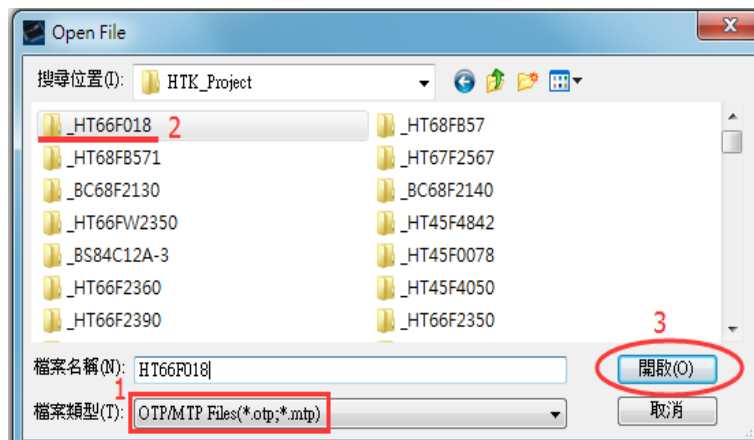

Fig. 2-2

- Step 3
Then download the opened file to the writer (Menu\File\Download) as shown in Fig. 2-3.

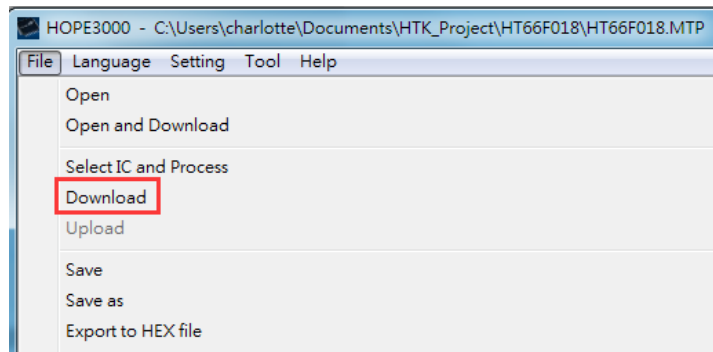

Fig. 2-3

It is required to choose the IC package as shown in Fig. 2-4.

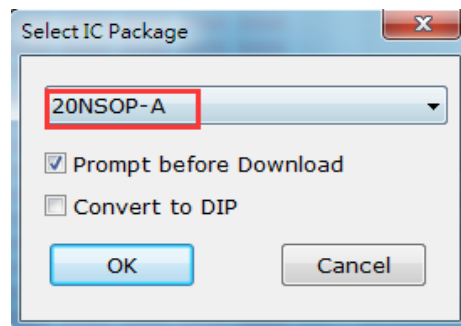

Fig. 2-4

- Step 4
After downloading, if successful, the lower message box will display “Complete and OK” (Fig. 2-5). Then programming can be executed by clicking the buttons “Blank Check”, “Program”, “Verify”, “Lock” (if locking IC is required) as shown in Fig. 2-5. In addition, the data in the Flash Memory can be cleared by clicking the button “Erase” if a Flash MCU is used.

For any problems, refer to Chapter 3 “Introduction to the HOPE3000 Main Functions”. For errors that have occurred during programming, refer to Appendix A “System and Writer Error Messages” for further information.

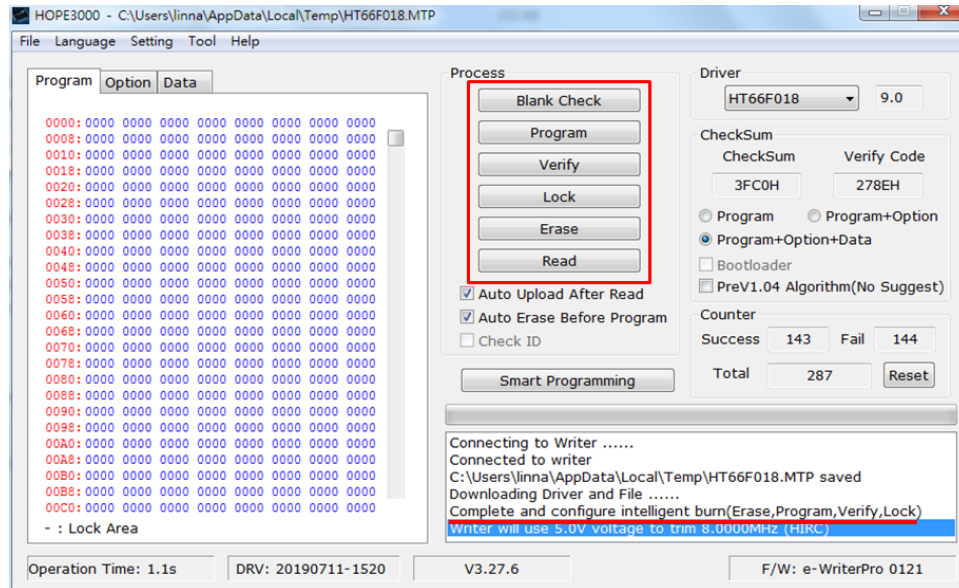

Fig. 2-5

Case. 2 – Auto Programming

Case. 1 shows how to implement programming on a PC. However it is still necessary to click the buttons “BlankCheck”, “Program”, “Verify” etc., to complete the programming process. There is another method whereby with a single setup on the HOPE3000, the full programming operation can be executed by only clicking the “Auto” button once. This is suitable for higher volume MCU programming operations. The operating steps are as follows.

- Step 1~3
Same as Step 1~3 in Case. 1.
- Step 4
Click the button “Smart Programming” as shown in Fig. 2-6. Then the Smart Programming UI will appear as shown in Fig. 2-7.
- Step 5
In the Smart Programming UI (Fig. 2-7), select the required programming operations (repeat the Action 1 and 2), and then download these settings to the writer (Action 3).

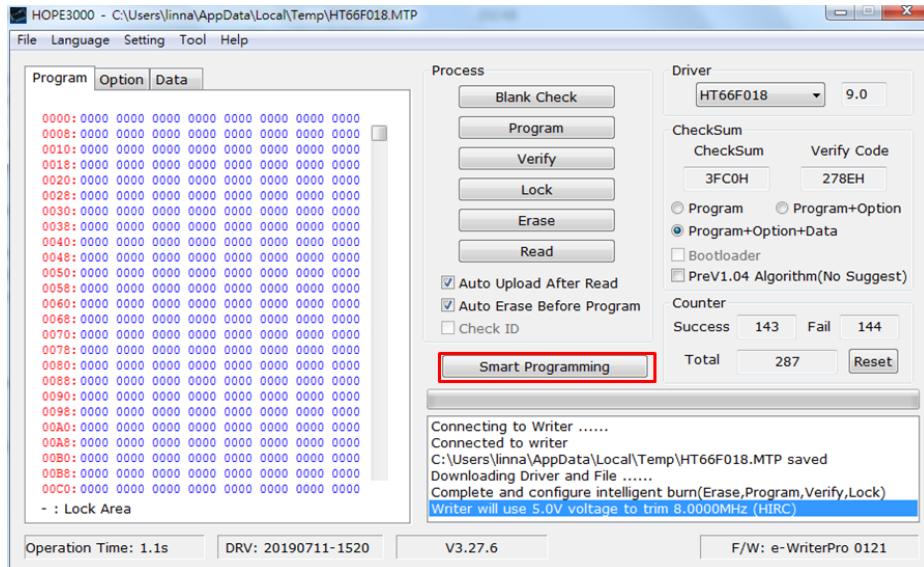

Fig. 2-6

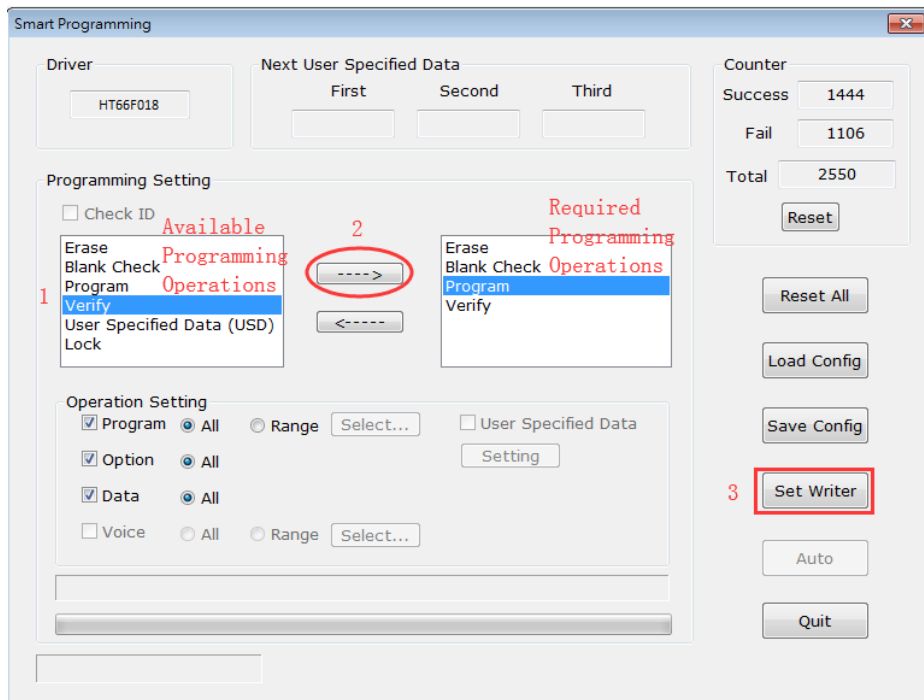

Fig. 2-7

- Step 6
If the download operation has been successful the button “Auto” on the lower right corner of Fig. 2-7 will be shown. By clicking on this button all the selected programming operations will be executed.

For any problems refer to Chapter 3 “Introduction to the HOPE3000 Main Functions” or Chapter 4 “Introduction to HOPE3000 Smart Programming Function”. For errors that have occurred during programming, refer to Appendix A “System and Writer Error Messages” for further information.

Case. 3 – IC Partial Programming

Some applications may have the demand of programming an IC for multiple times, which means to program partial data each time. The following steps will show how to program partial data.

- Step 1~4
Same as Step 1~4 in Case. 2.
- Step 5
Set the programming range as shown in Fig. 2-8. First, select the operation “Program” from the “Available Programming Operations” list (Action 1), then click the button “---->” (Action 2), after this the operation “Program” will appear in the “Required Programming Operations” list. By clicking on this operation (Action 3), the “Operation Setting” section will be enabled. Select the “Range” option (Action 4) and click the button “Select...” (Action5), then the window as shown in Fig. 2-9 will pop up for further range setting.

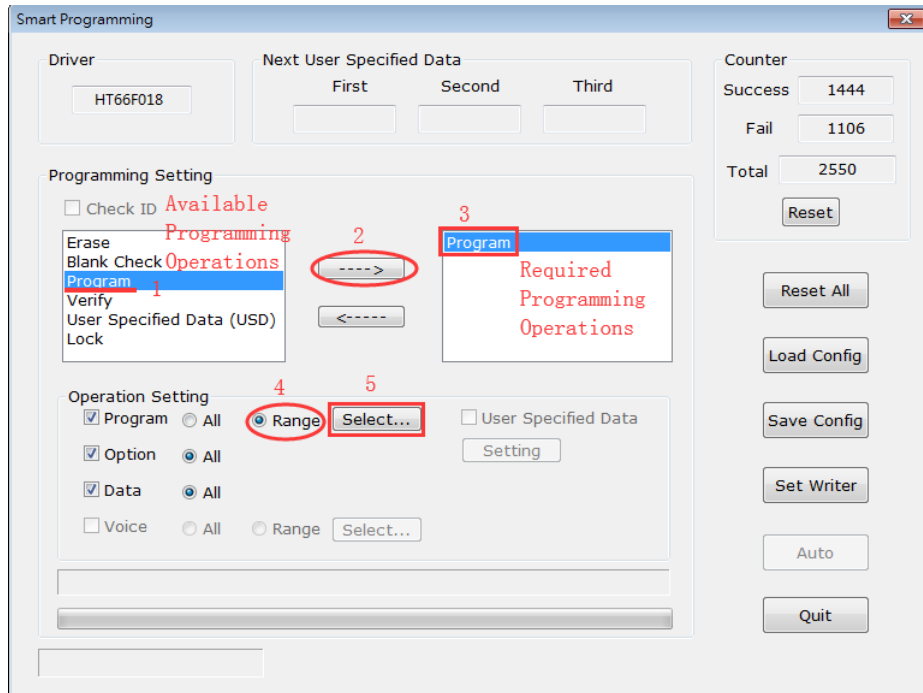

Fig. 2-8

- Step 6
 Select the “Map” mode as shown in Fig. 2-9 (Action 1) then the ROM range selection section will appear on the left side of the window. Then click the button “Add Select” (Action 2) and specify the programming section (Action 3). Finally click the button “OK” (Action 4) to store these settings and quit this window.

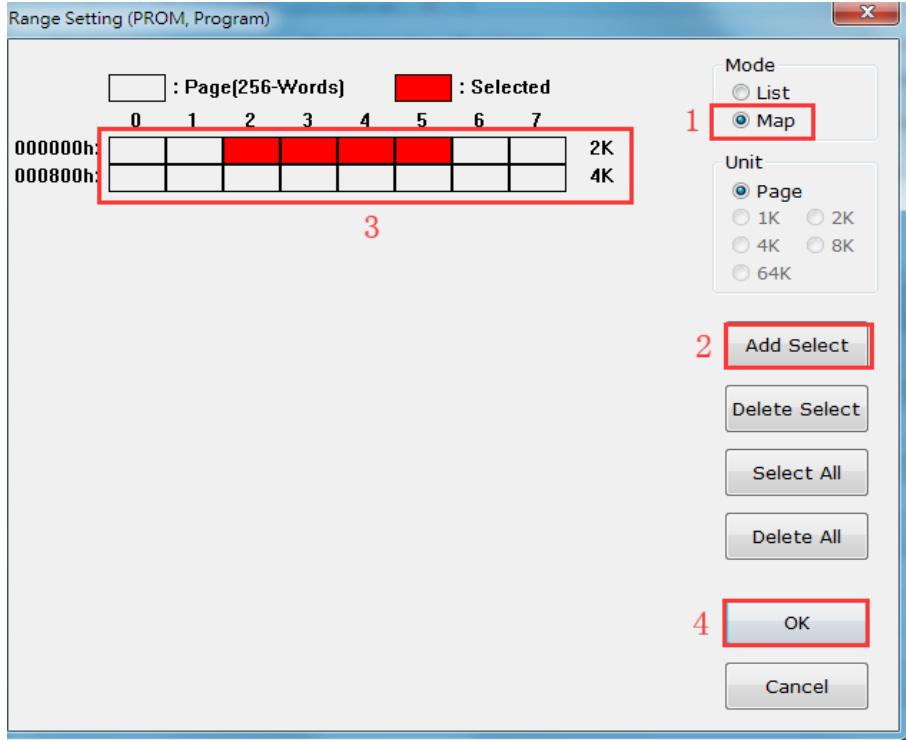

Fig. 2-9

- Step 7
Repeat Step 5~6 to add the programming operations “Erase”, “Blank Check”, “Verify” or “Lock” as shown in Fig. 2-10. Download these settings to the writer (Action 1), if the download operation has been successful, the button “Auto” will be shown. Then click this button (Action 2) to execute the specified operations. Thereafter, each programming operation is implemented by a single click on the button “Auto”.

For any problems refer to Chapter 3 “Introduction to the HOPE3000 Main Functions” or Chapter 4 “Introduction to HOPE3000 Smart Programming Function”. For errors that have occurred during programming, refer to Appendix A “System and Writer Error Messages” for further information.

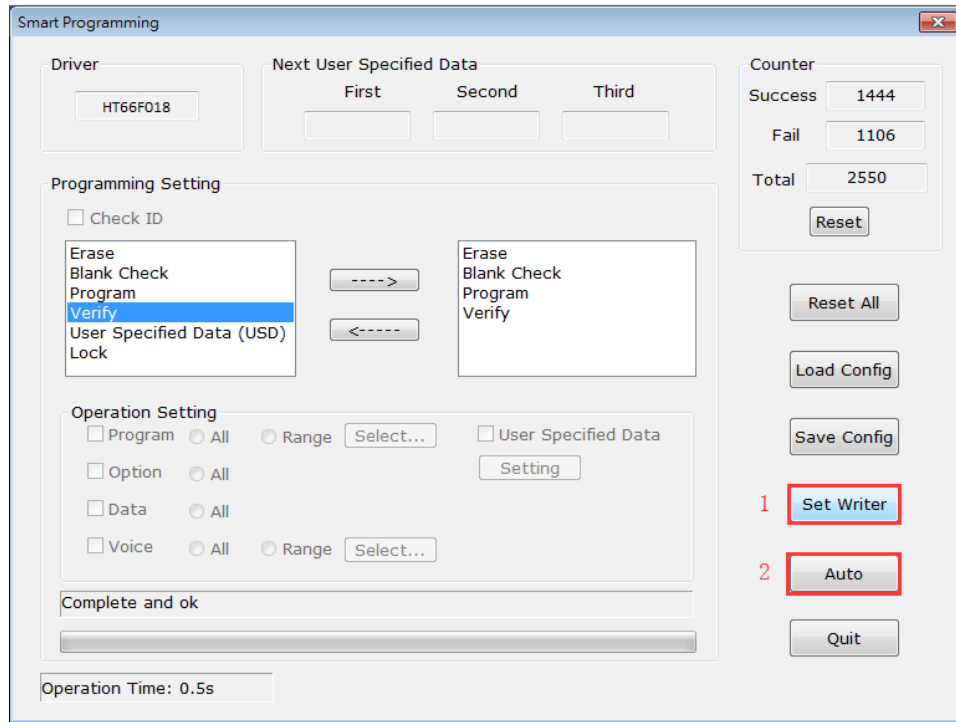

Fig. 2-10

Case. 4 – Programming Serial Numbers or Other Specified Data

To program serial numbers or other data into the Program Memory or EEPROM, use the function “User Specified Data” on the Smart Programming window. The following steps introduce how to use this function to program data into the Program Memory.

- Step 1~4
Same as Step 1~4 in Case. 2.
- Step 5
Same as Action 1~3 in Fig. 2-11, add the operation “User Specified Data” to the “Required Programming Operations” list. By clicking the button “Setting” (Action 4) in the “Operation Setting” section, the User Specified Data setting window will appear as shown in Fig. 2-12.
- Step 6
Set the specified data details. Fig. 2-12 demonstrates the setting to program data into the address 100H of the Program Memory. The data is generated by the mathematical expression “N+1” and the initial value of N is 22. This means that 22 is the first programmed IC, 23 for the second one, ...etc. After Action 1~3, click the button “OK” to store these settings and quit this window.
※ For other details, refer to the “User Specified Data Setting Window” section in Chapter 4 “Introduction to the HOPE3000 Smart Programming Function”.

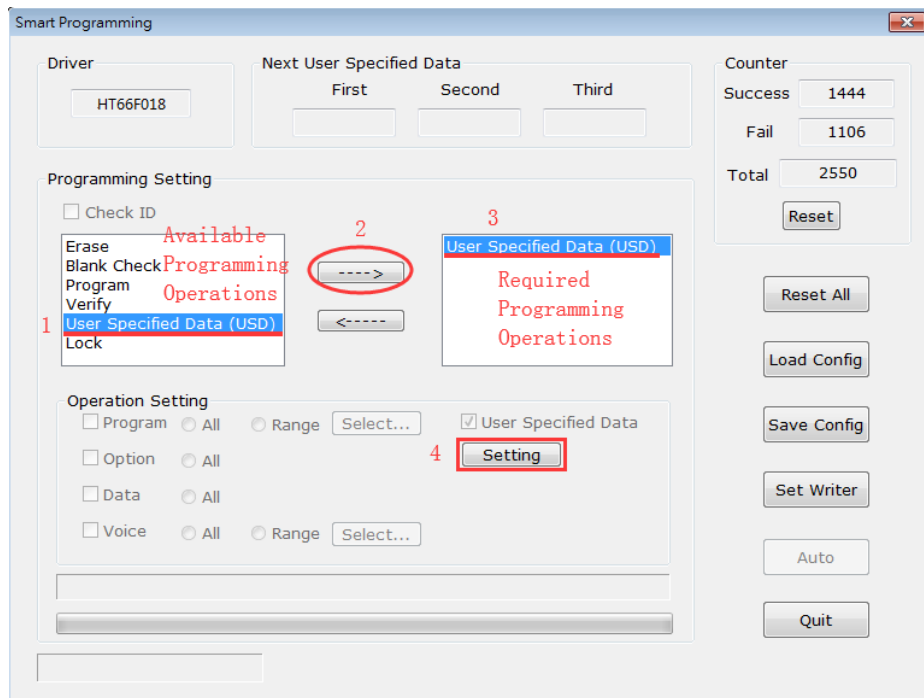

Fig. 2-11

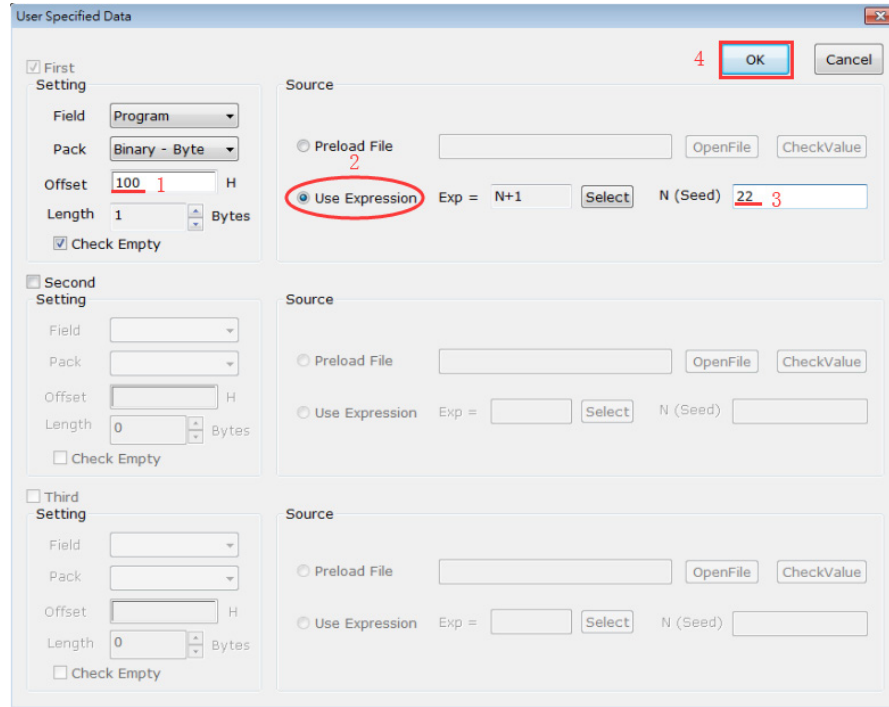

Fig. 2-12

- Step 7
Download these settings to the writer as shown in Action 1 in Fig. 2-13. The first data record to program is shown in Rectangle 3. Then click the button “Auto” (Action 2) to program. Each programming operation is implemented by a single click. After each programming operation, the record of the next data to program will be shown in Rectangle 3.

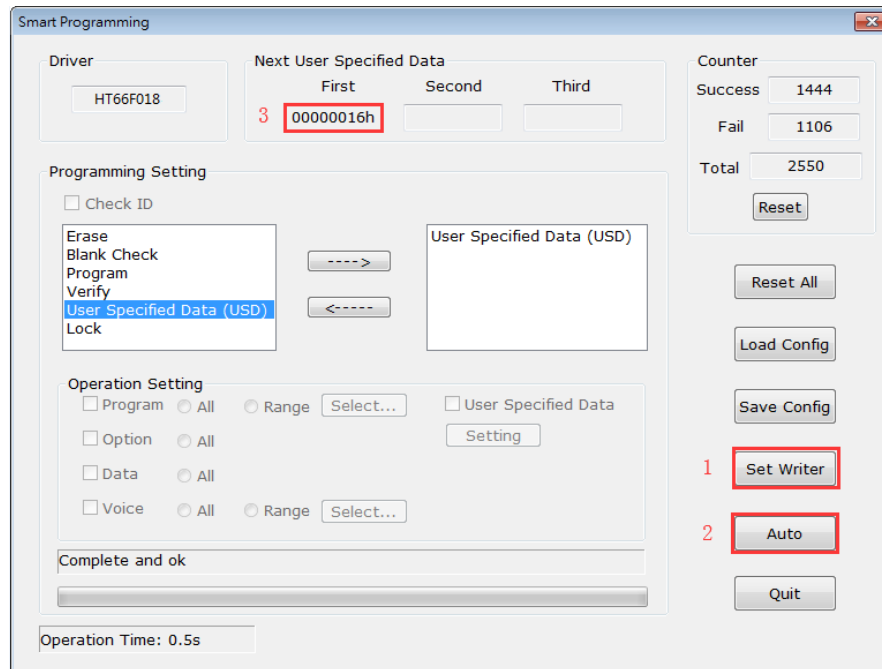

Fig. 2-13

In addition, users can also set the user specified data when setting the partial programming operation in Case. 3.

For any problems refer to Chapter 3 “Introduction to the HOPE3000 Main Functions” or Chapter 4 “Introduction to HOPE3000 Smart Programming Function”. For errors that have occurred during programming, refer to Appendix A “System and Writer Error Messages” for further information.

Case. 5 – Standalone Programming – Off-Line Mode

For standalone programming which means to operate the writer without connecting it to a PC, first connect the writer to a PC and download the programming file and programming operation settings to the writer. After this pressing the programming key on the writer will execute a programming operation. The details are as follows.

- Step 1~5
Download the programming file and programming operation settings to the writer as shown in Step 1~5 in Case. 2.
- Step 6
Exit the HOPE3000 and remove the USB connection from the writer.
- Step 7
Connect the power adapter to the writer and turn on the power. At this point the writer will check if the downloaded data in Step 1~5 is correct. If so then the writer will be in a Ready state (the yellow LED will be on), otherwise, it will be in a Fail state (the red LED will be on) requiring the data to be downloaded again to the writer (repeat Step 1~5).
※ The yellow LED must be on before continuing to the next step.
- Step 8
Insert the MCU into the programming adapter. The MCU type must be the same as the MCU type in the downloaded programming file in Step 1~5. Press the programming key (Fig. 1-9) on the writer to program the device.
- Step 9
Examine the LED and check if the programming operation has been successful (the blue LED flashes slowly and the other two LEDs are off).

If there is any problem, refer to Chapter 3 “Introduction to the HOPE3000 Main Functions” or Chapter 4 “Introduction to HOPE3000 Smart Programming Function”. For errors that have occurred during programming refer to Appendix A “System and Writer Error Messages” for further information. For problems regarding the LEDs refer to Appendix B “Writer LEDs and Status”.

Case. 6 – Reading Data from an MCU – Without using a Programming File

Generally, before reading data from the MCU, it is necessary to open the programming file for that device type or the data in the writer is for that device type. A method will now be introduced for situations where no programming file exists for the device type or the data in the writer is not for the present device type. Here data can be read from the MCU using the HOPE3000. The details are as follows.

- Step 1
Execute the command “Menu/File/Select IC and Process” as shown in Fig. 2-14.

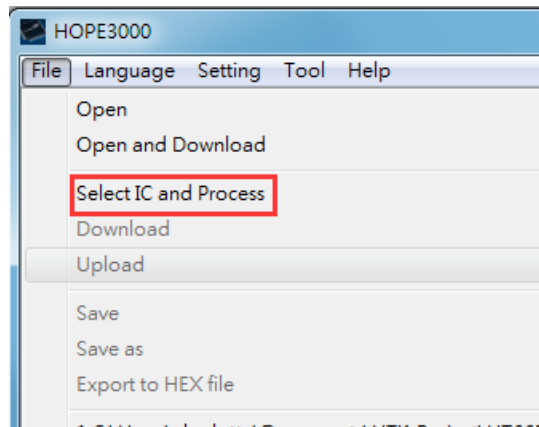

Fig. 2-14

- Step 2
The dialog “IC Select” will then pop up. Select the required IC type from the “From All IC” section as shown in Fig. 2-15 and click the button “OK” to quit this window.

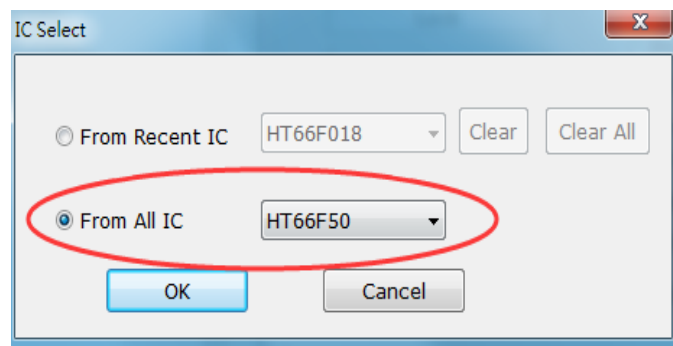

Fig. 2-15

It is required to select the MCU package type as shown in Fig. 2-16.

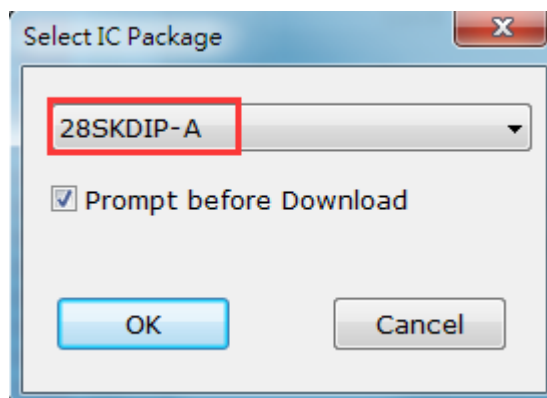

Fig. 2-16

- Step 3
Then the HOPE3000 will download the driver for that IC type to the writer. If successful, then parts of the buttons in the “Process” section will be enabled as shown in Fig. 2-17. Now the “Read” button can be clicked to read data from the IC directly. Then execute the command “Menu/File/Upload” to upload and show the data on the HOPE3000.

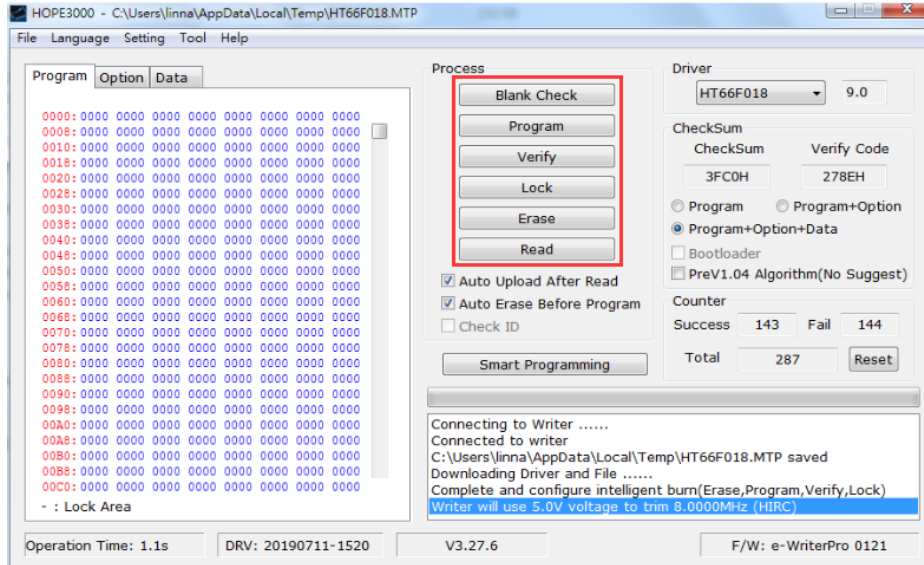

Fig. 2-17

For any problems refer to Chapter 3 “Introduction to the HOPE3000 Main Functions”. If any errors have occurred during programming, refer to Appendix A “System and Writer Error Messages” for further information.

Case. 7 – Executing the Programming Operations by Command Method

The HOPE3000 supports the command mode, i.e., DOS Command Mode. The steps to start the mode are as follows.

- Step 1
Exit the HOPE3000 and execute the program “Command Prompt” under the Microsoft Windows.
※ The HOPE3000 and DOS Command Mode program should not be executed at the same time, otherwise it will affect the programming result.
- Step 2
Drag the WCMD.exe program from the HOPE3000 installation directory into the “Command Prompt” window. Enter the command: -con after a space and then press the Enter key, as shown in Fig. 2-18.

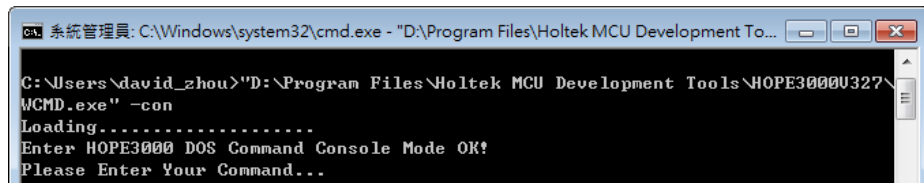

Fig. 2-18

- Step 3
Enter the command: >wcmd/? and press the Enter key to open a simple instruction as shown in the red rectangle in Fig. 2-19. Then enter the command following the instruction.

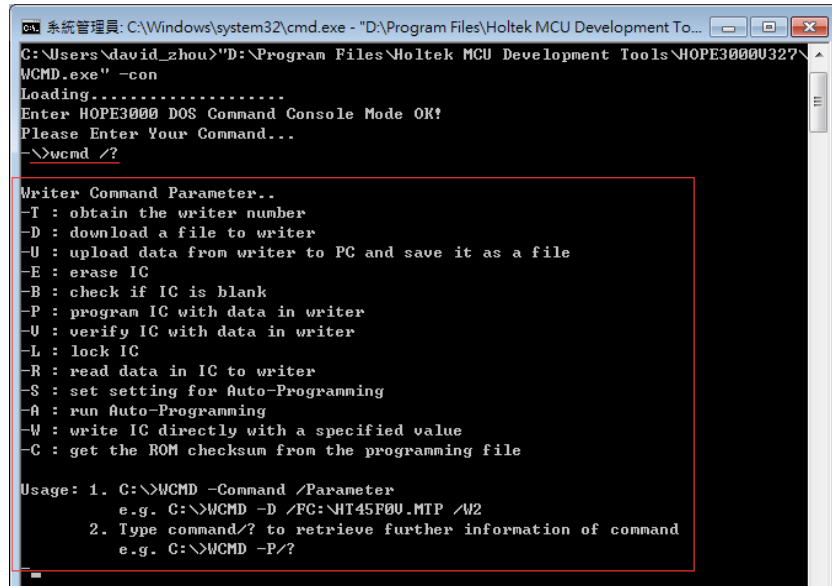

Fig. 2-19

For any problems regarding the DOS Command Mode, refer to Chapter 5 “Introduction to HOPE3000 – DOS Command Mode”. For errors that have occurred during programming, refer to Appendix A “System and Writer Error Messages” for further information.

Case. 8 – Updating the Writer Firmware via a PC

The e-WriterPro has a function to update its firmware via a PC. The following steps introduce how to update its firmware version to the one in the HOPE3000. Ensure that the HOPE3000 is the latest version before updating.

- Step 1
Execute “Menu/Tool/F/W Update” to open the F/W update window, as shown by the red rectangle in the upper section in Fig. 2-20. Note that the F/W version before updating is shown on the right lower corner of Fig. 2-20.

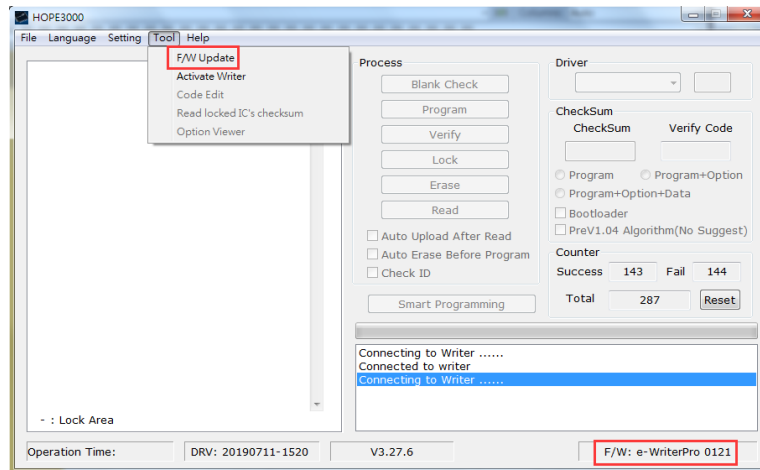

Fig. 2-20

- Step 2
Fig. 2-21 is the F/W update window. Click the “Start” button to start the F/W update.

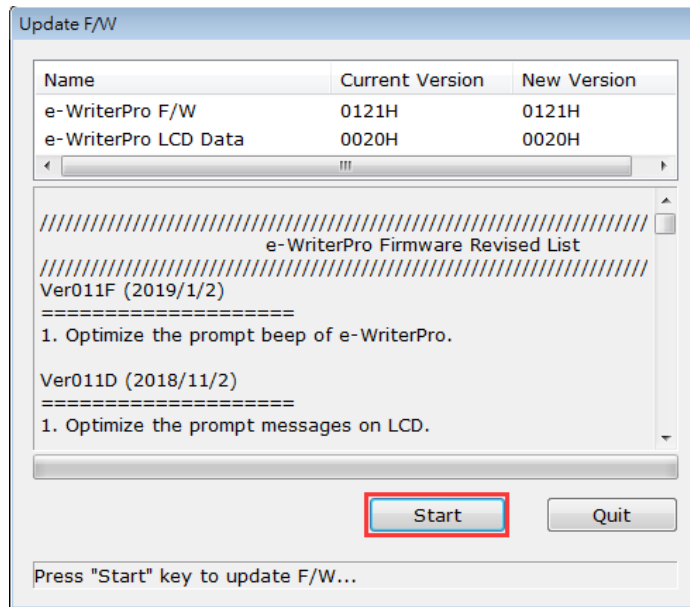

Fig. 2-21

- Step 3
If the writer is connected, then the F/W update process starts.

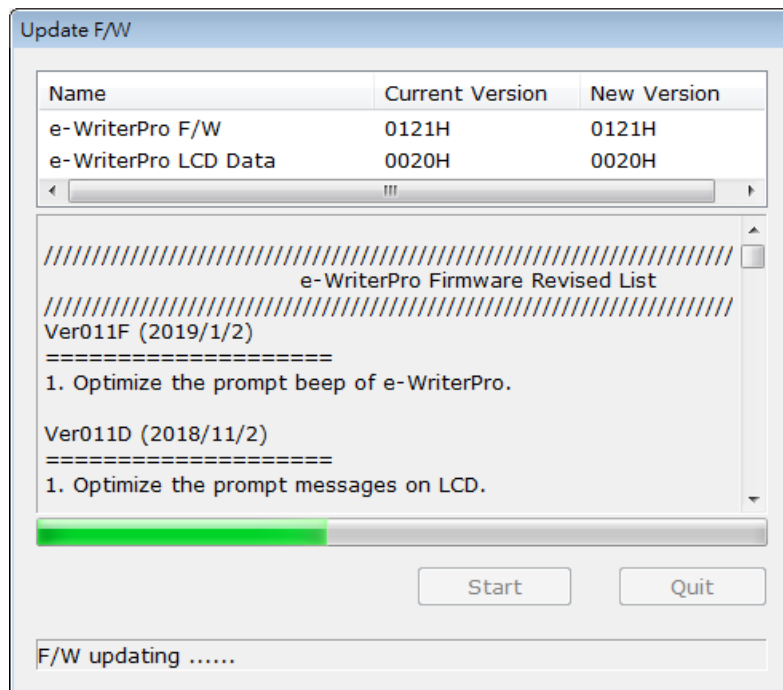

Fig. 2-22

※ If the window, as shown in Fig. 2-23, appears after clicking “Start”, it means that the F/W version is the same as or newer than the one in the HOPE3000. It is therefore suggested not to update as it might update to an older F/W version.

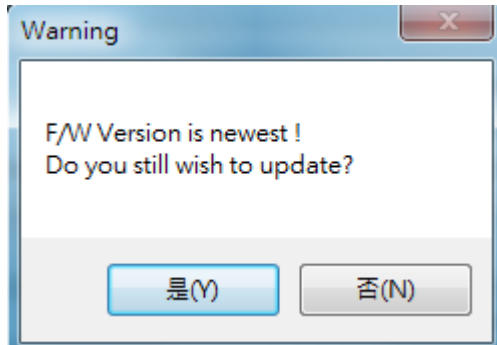

Fig. 2-23

- Step 4
 If the update has been successful, the F/W update window will show “Update Firmware OK” (Fig. 2-24). Then the HOPE3000 will power on the writer automatically and after it is connected, the updated F/W version will be shown on the right lower corner as shown in Fig. 2-24.

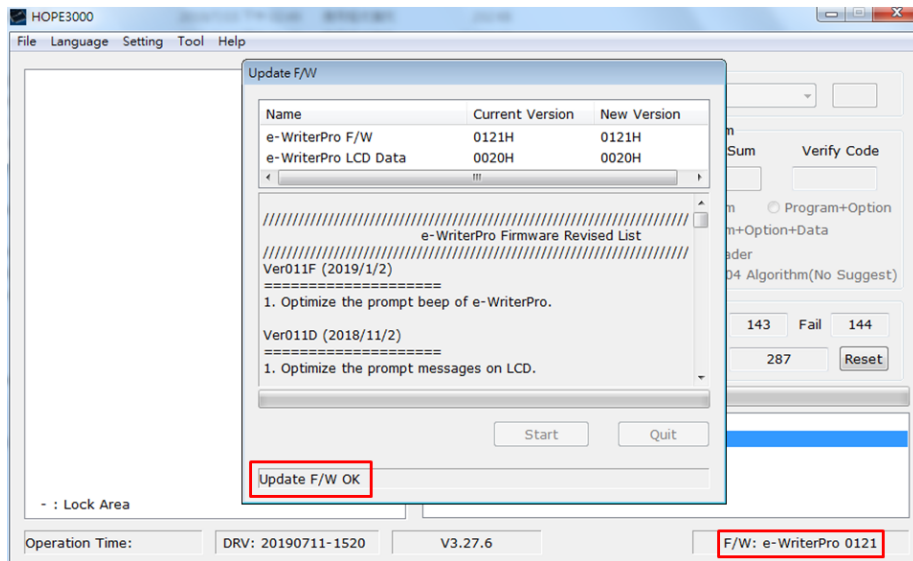

Fig. 2-24

For any problems refer to Chapter 3 “Introduction to the HOPE3000 Main Functions”. For errors that have occurred during programming refer to Appendix A “System and Writer Error Messages” for further information.

Case. 9 – Registering and Activating the Writer

A new e-WriterPro needs to be first activated otherwise programming operations will not be possible. To activate the writer, a registration code must first be obtained for the writer. The following steps show how to register and activate the e-WriterPro.

- Step 1

Execute “Menu/Tool/Activate Writer” to open the “Writer Activation” window. Note that when the writer is not activated, a warning message will show on the lower right corner of Fig. 2-25.

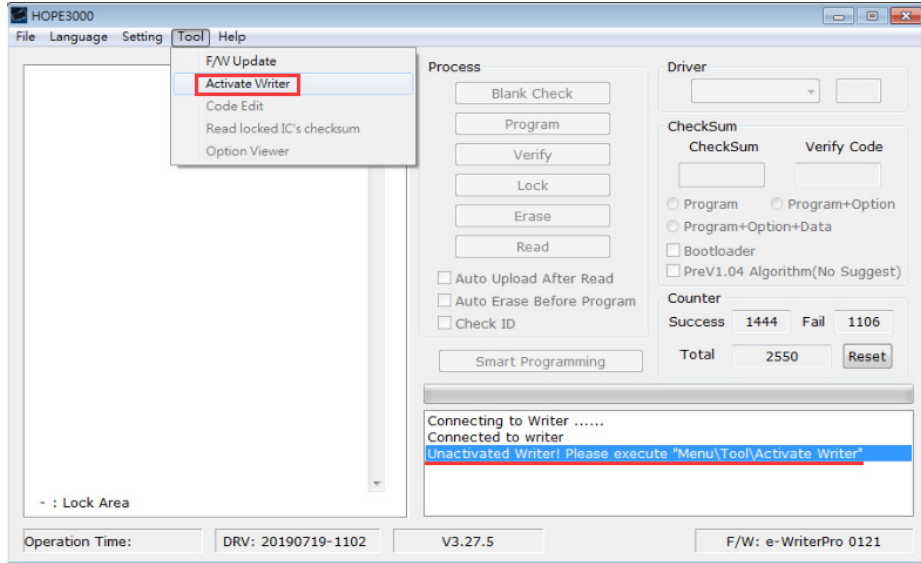

Fig. 2-25

- Step 2

Fig. 2-26 shows the “Writer Activation” window. The red rectangle shows the detected Writer ID. Click the button “Get Register Code” to register this writer. If the registration code has already been obtained, then jump to Step 6 to activate the writer.

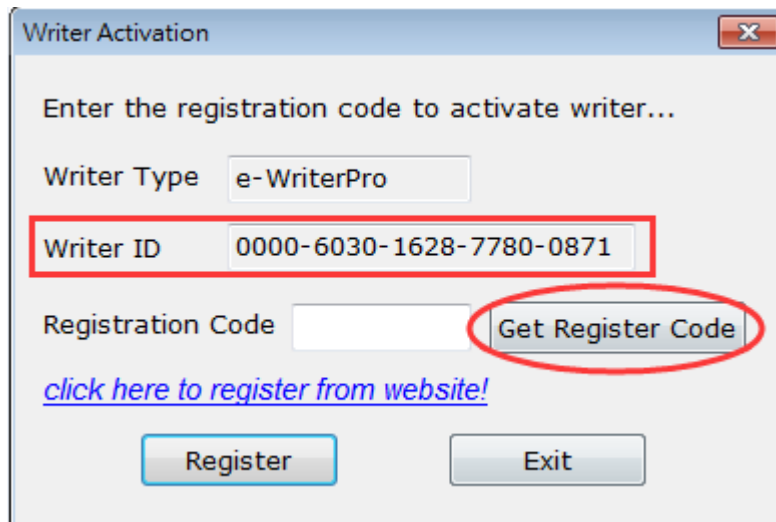
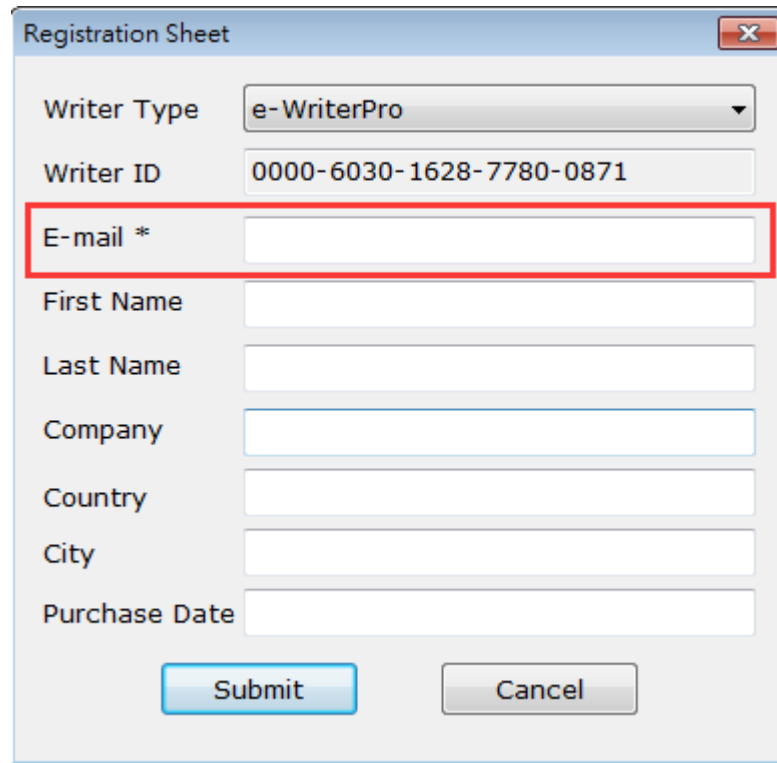

Fig. 2-26

- Step 3

Fig. 2-27 is the registration sheet, where the * sign shows the necessary field. In the E-mail field, fill in a valid e-mail address to obtain a mail containing the registration code. Do not enter other person's mail address to prevent misuse of the registration code. The other fields should also be properly filled in for our after-sales service. Users' information will be protected by Holtek. When it is finished, click the button "Submit".



The image shows a dialog box titled "Registration Sheet" with a close button (X) in the top right corner. The dialog contains several input fields and two buttons at the bottom. The fields are: "Writer Type" (a dropdown menu showing "e-WriterPro"), "Writer ID" (a text box containing "0000-6030-1628-7780-0871"), "E-mail *" (a text box with a red border around it), "First Name", "Last Name", "Company", "Country", "City", and "Purchase Date". At the bottom, there are two buttons: "Submit" (highlighted in blue) and "Cancel".

Fig. 2-27

- Step 4

If the registration is successful, the dialog as shown in Fig. 2-28 will appear after which a registration mail will be sent to the provided mail address. If the registration fails, try Step 3 again. If it still can not be registered successfully, contact Holtek to resolve the problem.

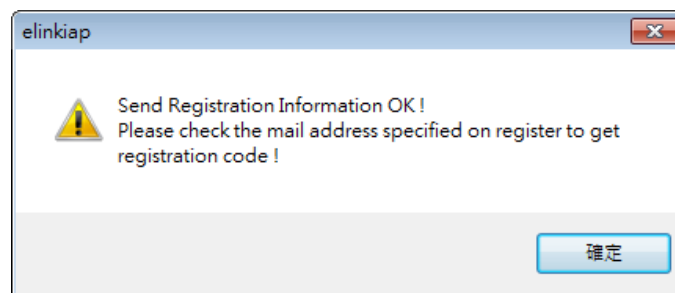

Fig. 2-28

- Step 5
If the specified email address is correct, then an email will be received from Holtek with the title “Holtek Tools Registry Key”.

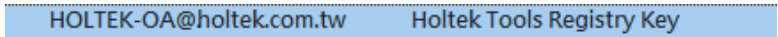

Fig. 2-29

After opening the mail the registration code will be seen as shown in the red rectangle in Fig. 2-30 (the figure only shows part of the full registration mail).

Hi!
 Now that you've registered your e-WriterPro (ID: *****77800871), please use the following registration code to activate your tool.
 The Registration Code of your tool **047733**

Fig. 2-30

- Step 6
Fill in the registration code in the “Writer Activation” window of the HOPE3000 (red rectangle 1 in Fig. 2-31) and click the button “Register” to activate the writer.



Fig. 2-31

- Step 7
If the activation is successful, then a success message will appear as shown in Fig. 2-32. After this, the writer is now ready for programming. If the activation fails, check that the registration code has been entered correctly in Step 6 or try again from Step 1. If the problem can not be resolved then contact Holtek to resolve the problem.

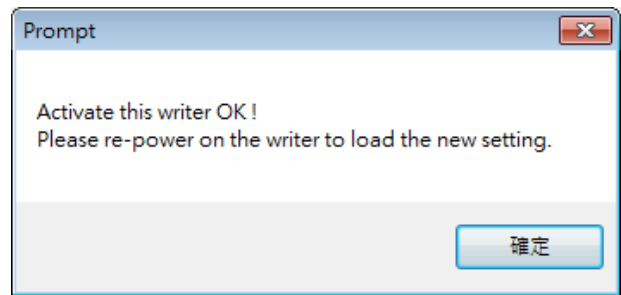

Fig. 2-32

For any problems refer to Chapter 3 “Introduction to the HOPE3000 Main Functions”. For any errors have occurred during the registration or activation, refer to Appendix A “System and Writer Error Messages” for further information.

Case. 10 – Using external digital signals to control e-WriterPro Programming

The following describes two methods of using external digital signals to control the e-WriterPro programming. These two methods are connecting a button to the e-WriterPro and using digital signal to control e-WriterPro programming. These two methods are the same as pushing the red programming key on the e-WriterPro, however the second method can also obtain the programming result.

Method 1 – Connect an external button

Connect a button to the Pin2/Pin4 of the e-WriterPro CN3 connector directly, as shown in Fig. 2-33, 2-34.

Diagram:

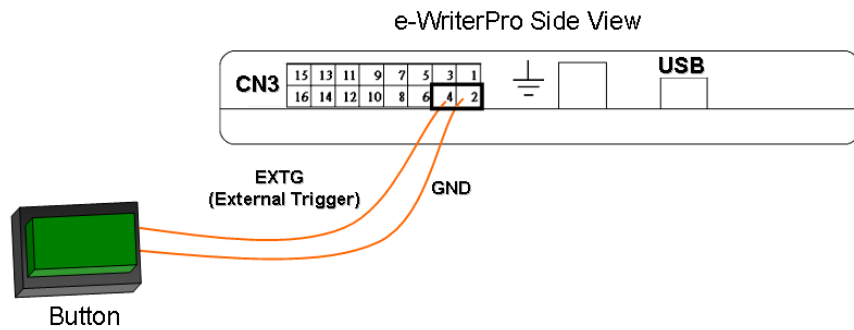

Fig. 2-33

Picture:

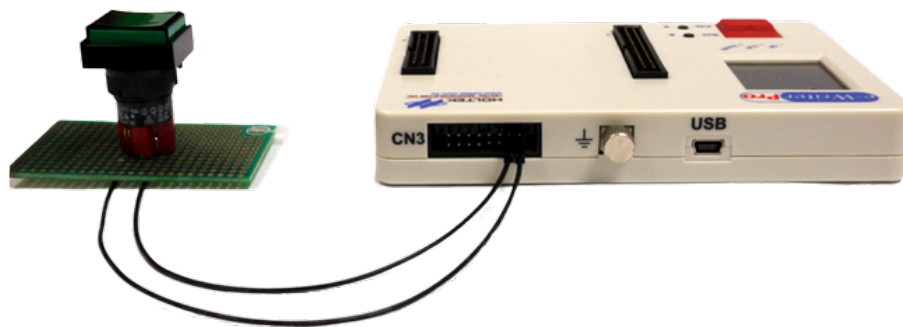

Fig. 2-34

Method 2 – Digital Signal Control

The operation for using digital signals to control the e-WriterPro programming is: connect using the method as shown in Fig.2-35 and input the control signal timing.

1. Hardware Connection Diagram

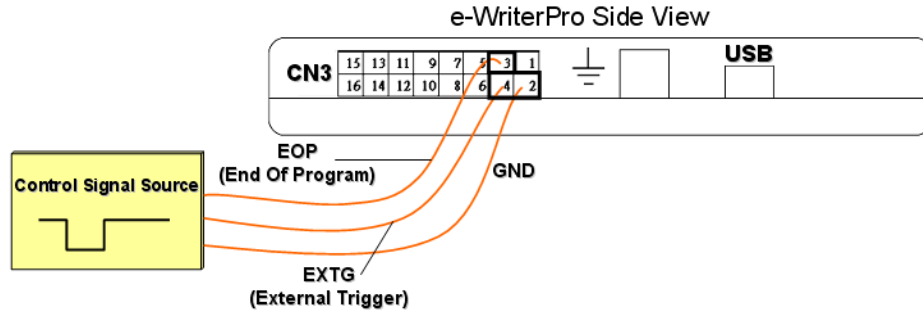

Fig. 2-35

※ If the programming result is required, refer to Appendix D “e-WriterPro CN3 Pin Definitions” to connect to the corresponding BIN1~BIN7 pins. Then follow Step 3 of the following “Usage & Control Signal Timing” section to obtain the programming result.

2. Usage & Control Signal Timing

Control Signal Timing diagram

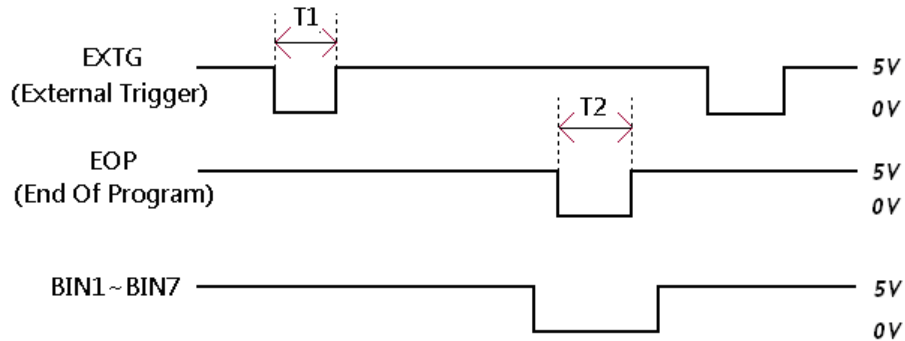

Fig. 2-36

T1: e-WriterPro “External Trigger” low pulse, $10\text{ms} < T1 < 500\text{ms}$

T2: e-WriterPro “End Of Program” low pulse, $12\text{ms} < T2 < 100\text{ms}$

The usage is as follows:

- 1) Input a low pulse on the EXTG pin to start programming as shown by T1 in Fig. 2-36. This operation is the same as pushing the red programming key on the e-WriterPro.
- 2) Then the EOP pin can be polled continuously. If a low pulse is detected, as shown by T2 in Fig. 2-36, this means that the programming is finished.
- 3) During the EOP low pulse as shown by T2 in Fig. 2-36, check the status of BIN1~BIN7 to obtain the programming result. For example, if BIN1 is low during T2, this means Program OK. However if BIN4 is low during T2, this means Program Fail because the device is not blank.

Case. 11 – Using the e-WriterPro In-circuit Programming Function

The following steps show how to use the e-WriterPro to implement in-circuit programming – ICP.

- Step 1
Use the ICP cable as supplied with the e-WriterPro and shown in Fig. 1-1. It is used to connect the target board with the connector CN1 on the e-WriterPro. For more information about the connection method, refer to the Appendix C “e-WriterPro ICP Pin Definitions and ICP Considerations”.
- Step 2
Execute the HOPE3000 and open the programming file (.OTP/.MTP/.PND). Then select “Menu/ File/ Download”.
- Step 3
Before downloading, the window as shown in Fig. 2-37 will appear. Then the ICP package type should be selected correctly. Regarding the package selection, refer to the Appendix C – e-WriterPro ICP Pin Definitions and ICP Considerations. If the required package type is not shown, upgrade the HOPE3000 to the latest version.

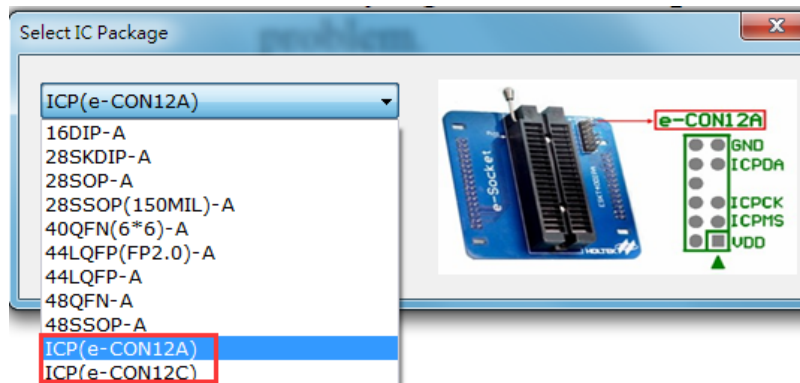

Fig. 2-37

- Step 4
After the download has finished, the Erase, Program and Verify operations, etc., can be executed. If there is any problem, refer to Chapter 3 “Introduction to the HOPE3000 Main Functions” and Appendix C “e-WriterPro ICP Pin Definitions and ICP Considerations” for more information.

Case. 12 – Setting a Limit on the Programming Times

After a limit on the programming times has been set, the writer will stop the programming operation once the limit is reached. In this condition, users can use a specific software programming times recharge or reupload the HOPE3000 and set the limit again.

- Step 1
Execute “Menu/Setting/Security Mode” to turn on the security mode.

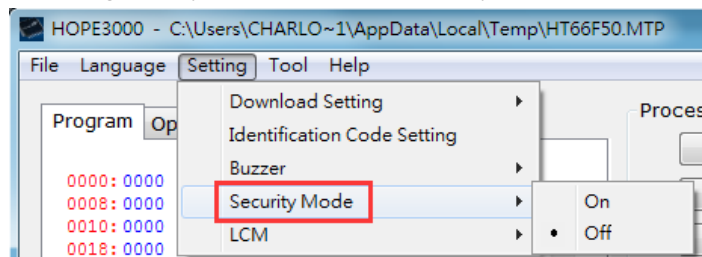

Fig. 2-38

- Step 2
After the Step 1 is executed, a window as shown in Fig. 2-39 will pop up. Click “Start” to update F/W.

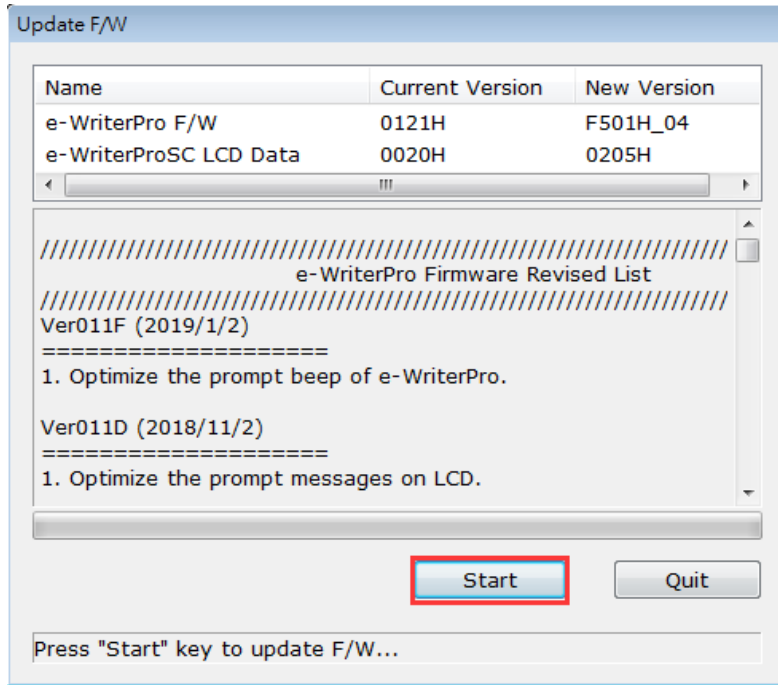

Fig. 2-39

- Step 3
Execute “Menu/File/Open or Open and Download” as shown in Fig. 2-40.

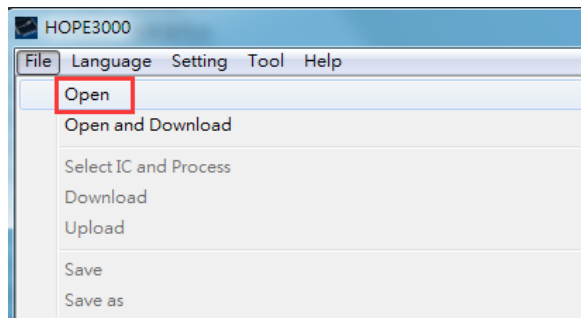

Fig. 2-40

- Step 4
After the Step 3 is executed, a window as shown in Fig. 2-41 will pop up.
 A: Programming Setting. It includes “Custom MCU Name”, “Restrict burn times” (max. 130000) and the available programming operations.
 B: Set Password. The password should contain six discrete digits.
 C: Click “Set Writer” then the setting is now finished.
 Note: After setting the writer an information record document – “InformationForSN.dat” will be generated, which is used together with a specific software to generate a programming times recharge document. This specific software is provided independently, contract Holtek for the software if required.

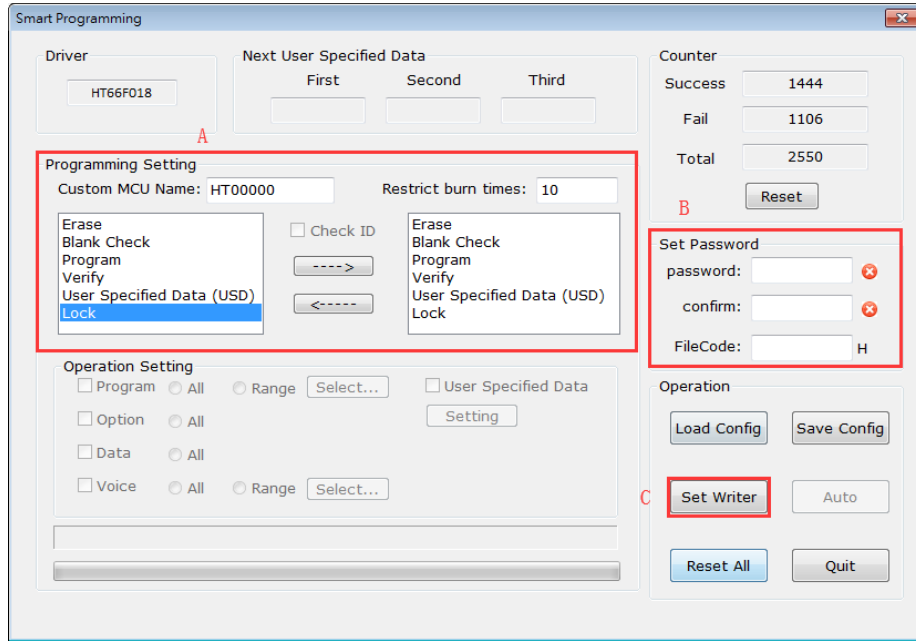

Fig. 2-41

Chapter 3 Introduction to the HOPE3000 Main Functions

The main task of the HOPE3000 Main UI is to handle the operations to program the entire IC. This UI is divided into six sections as shown in Fig. 3-1. The following will introduce the details of each section.

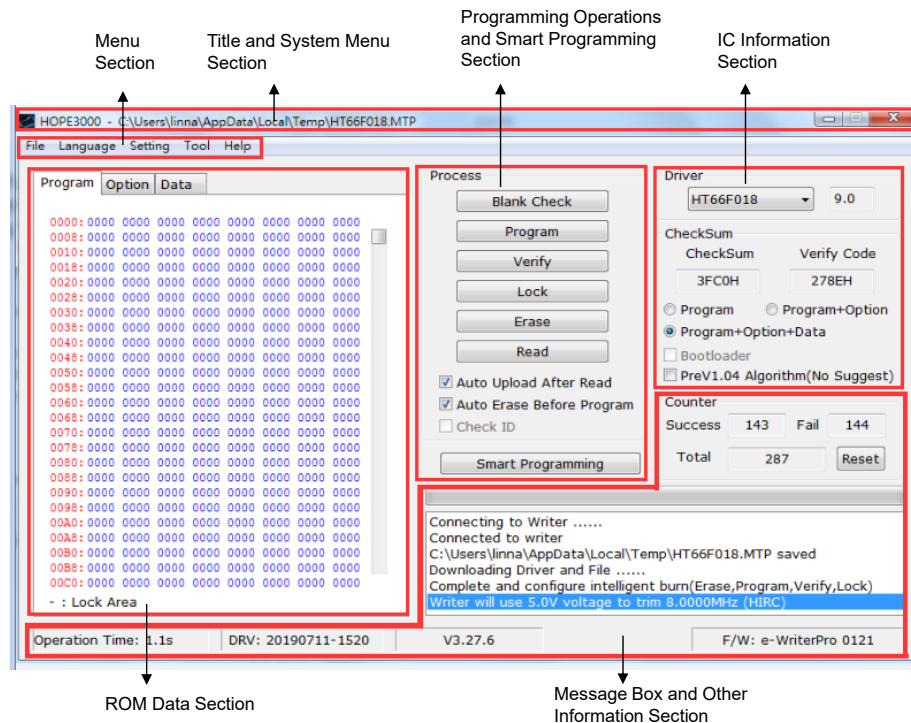

Fig. 3-1

Menu Section

File Menu

Fig. 3-2 shows the File Menu commands.

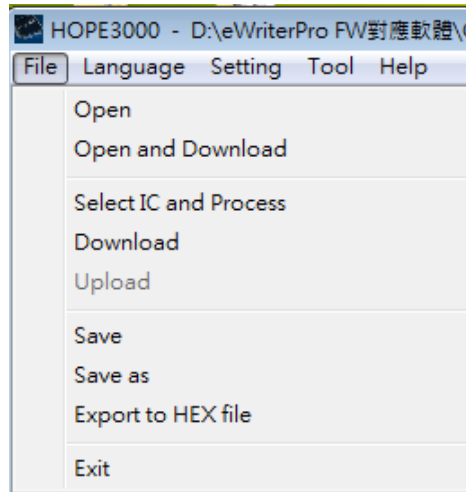

Fig. 3-2

- Open
Open the programming file. After executing this command, the program switches its UI to the proper file type. It supports the following file types:
OTP – OTP MCU
MTP – Flash MCU
PND – MCU with SPI Flash
APF – Advanced Programming File, reserved for future programming functions
R36 – Programming file for the HT81R36
- Open and Download
Open the programming file and download it to writer.
- Select IC and Process
Using this command allows programming operations by only selecting the required IC type without first opening any programming file.
- Download
Download the opened programming file to the writer.
- Upload
Upload the data in the writer, which includes the programming file, to the HOPE3000 and save it.
- Save
Save the data in the HOPE3000 UI as a file which will replace the original file.
- Save As
Save the data in the HOPE3000 UI as a file with a different name.
- Export to HEX File
Save the data in the HOPE3000 as an Intel standard HEX file.
- Exit
Exit the HOPE3000 program.

Language Menu

It is used to change the UI language. Supported languages include Traditional Chinese/Simplified Chinese/English as shown in Fig. 3-3. After selecting, the UI language is changed immediately.

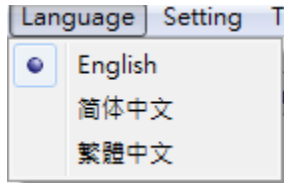

Fig. 3-3

Setting Menu

There are several setting items available as shown in Fig. 3-4.

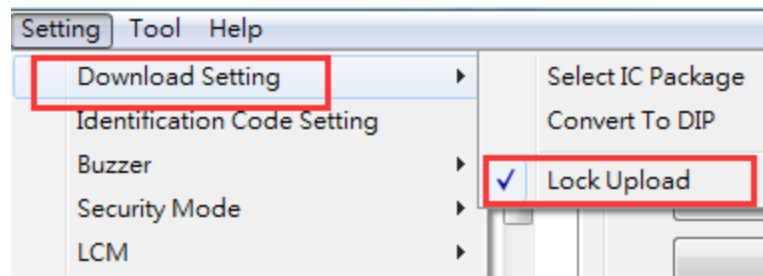

Fig. 3-4

- Download Setting/Select IC Package
This is used to select and change the IC package type.
- Download Setting/Convert To DIP
The IC to be programmed is not supplied in the DIP package type. When placing the adapter on the DIP locker for programming, this item should be selected.
- Download Setting/Lock Upload
This item, which is selected by default, is used to prevent the reading back of data in the writer using the Upload function.
- Identification Code Setting
This is used to program the user-defined identification code to the Option area of the IC as its identification or other purposes.
- Buzzer
This setting can adjust the buzzer volume for which there are four selections: Loud/Low/Mute/Alarm. The alarm sound is generated when any error has occurred during the programming operation.
- Security Mode
This is used to set the limit on the programming times protecting users' development results. For more details refer to the Case 12 in Chapter 1.
- LCM
The LCM display function includes two modes, which are the default mode and simple mode. In the default mode, the display contents include Holtek logo, product name, smart programming setting, checksum and verify code. In the simple mode, these information can be individually selected whether to display on the LCM.

Tool Menu

Fig. 3-5 shows the Tool Menu commands.

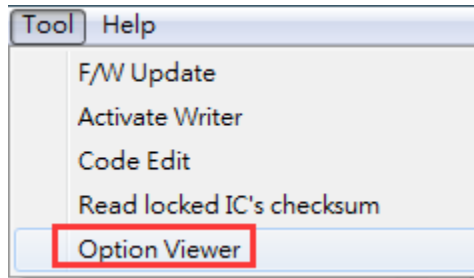

Fig. 3-5

- F/W Update
Update the firmware of the writer.
- Activate Writer
Register the newly purchased writer. The writer can not be used until it is activated.
- Code Edit
Modify the programming file original data. When using this function, users do not need to return to the HOPE3000 to compile again to modify parts of data. The data can be modified in this window and then click “OK”.
※ After modification, it is necessary to execute “Menu/File/Download” to download the modified data to the writer.
- Read locked IC’s checksum
Obtain the locked IC’s checksum and verify code when the IC is locked.
- Option Viewer
Preview the MCU configuration options, etc. The premise is that the HT-IDE3000 has been installed.

Help Menu

Fig. 3-6 shows the Help Menu commands.

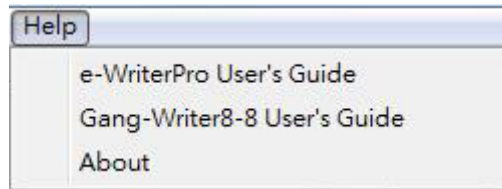

Fig. 3-6

- e-WriterPro User’s Guide
Open the e-WriterPro User’s Guide. Its language is the same as the HOPE3000.
- About
Show the version and copyright information of the HOPE3000 as shown in Fig. 3-7. Rectangle 1 in this figure shows the HOPE3000 version number, released date and driver file version. Rectangle 2 shows the version of the current writer firmware and the writer ID.

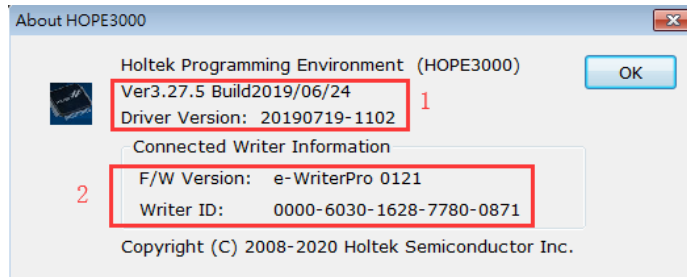

Fig. 3-7

ROM Data Section

This section displays the contents of the programming file. It can display the data of four ROM sections: Program, Option, Data and Voice. In Fig. 3-8, in the rectangle on the left side shows the addresses of the ROM section. On the right side is the data in the ROM section. Furthermore, the range “----” in this figure represents the IC locked part.

In the ROM section data part (the rectangle on the right side), there are two colours to identify if the data in the HOPE3000 is the same as that in the writer. The following explains these two conditions:

- When the data in the HOPE3000 is the same as that in the writer
The colour in the ROM section data part is blue and the buttons of the programming operations such as “BlankCheck” are enabled. This means that the programming operations can be executed.
- When the data in the HOPE3000 is different from that in the writer
The colour in the ROM section data part is red and the buttons of the programming operations such as “BlankCheck” are all disabled. This means that any programming operations can not be executed until the data in the HOPE3000 is the same as that in the writer. This is done by executing the commands “Download”, “Upload” or “Select IC and Process” on “Menu/File”.
※ The on-line programming operations are not allowed when the data shown in the HOPE3000 is not the same as that in the writer.

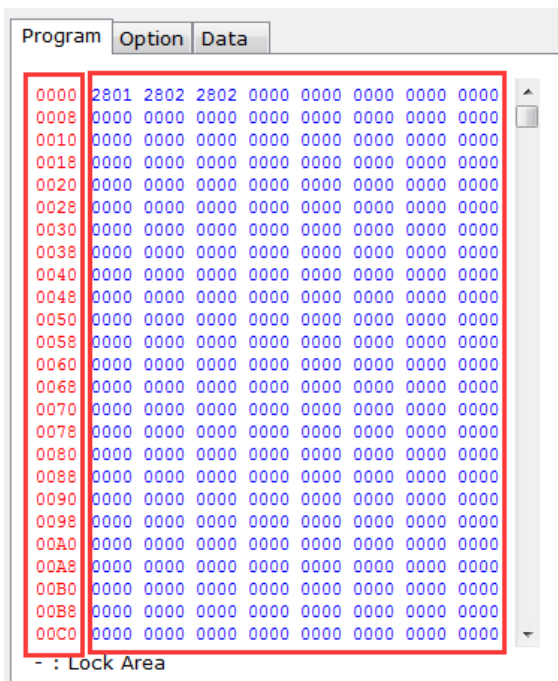

Fig. 3-8

Message Box and Other Information Section

This section is divided into several parts as shown in Fig. 3-9, which will now be introduced.

- Counter
Count the successful, failed and total counts for the IC programming. These three values are stored in the Windows Registry. Clicking the button “Reset” will clear all these three values to 0.
- Execution Time
Show the time required to execute the writer related operations such as Download, Program. Usually, this is used to measure the programming time.
- F/W Version
Show the writer type (e.g. e-WriterPro) and F/W version in this location when the writer is connected.
- Progress Bar
Show the download process status, upload or programming operations.
- Message Box
Show the execution result of any operation or the writer status.

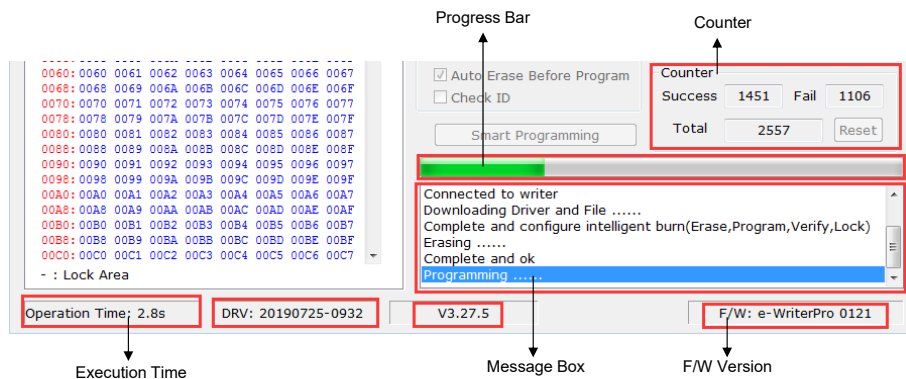

Fig. 3-9

IC Information Section

As can see in Fig. 3-10, there are two parts: Driver and Checksum.

- Driver
Show the driver type and version. The driver type is the IC type in the opened file or selected in the command “Menu/File/Select IC and Process”. For example, in Fig. 3-10, the driver type is HT66F50 and the driver version is 1.0. In addition, before downloading the programming file to the writer, check whether the driver type is the same as the IC to be programmed.
※ The IC driver information is recorded and each IC type has its own driver. When downloading, the driver and the programming file are downloaded at the same time.
- Checksum
The checksum of the ROM section data. There three ways to calculate the checksum of the ROM section Data:
“Program” calculates the checksum of the Program section.
“Program + Option” calculates the checksum of the Program and Option sections.
“Program + Option + Data” calculates the checksum of the Program, Option and Data sections.
※ This checksum is not the OTP/MTP/PND file checksum.

The BootLoader option is used to select whether the checksum calculation includes the BootLoader code. This option is only available if the IC contains this function and its programming file includes the BootLoader code.

The “PreV1.04 Algorithm (No suggest)” option should remain unselected in order to maintain the latest checksum algorithm.

※ The algorithm before V1.04 calculates all the data in the specified ROM area. However, for the algorithm of V1.04 or later, i.e., the latest algorithm, the TRIM area, where the HIRC/LVR calibration and other values are stored, is not included in the checksum calculation. As the values in the TRIM area of each IC may be different, after reading the IC information the checksum displayed on the HOPE3000 may also be different. In order to facilitate users to check whether the IC data has been programmed correctly, the TRIM area is excluded in the calculation.

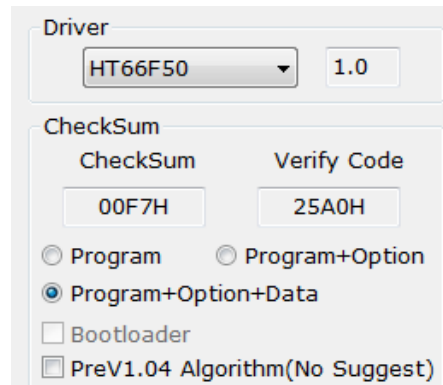

Driver

HT66F50 1.0

CheckSum

CheckSum Verify Code

00F7H 25A0H

Program Program+Option

Program+Option+Data

Bootloader

PreV1.04 Algorithm(No Suggest)

Fig. 3-10

Programming Operations and Smart Programming Section

This includes six basic programming operations including Blank Check, Program, Verify, Lock, Erase and Read, Smart Programming and three programming settings, as shown in Fig. 3-11. These buttons are enabled only after downloading the programming file to the writer. The following describes the command details.

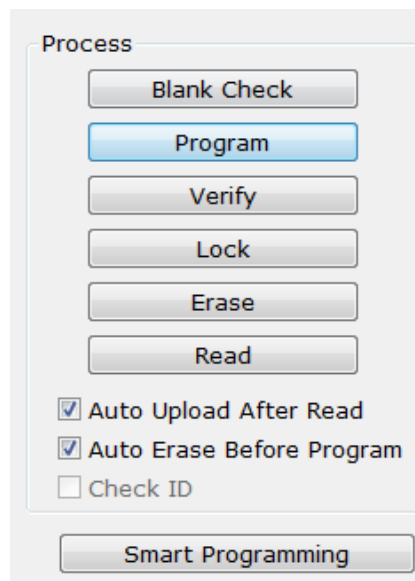

Process

Blank Check

Program

Verify

Lock

Erase

Read

Auto Upload After Read

Auto Erase Before Program

Check ID

Smart Programming

Fig. 3-11

- **BlankCheck**
Check if the IC in the writer has been programmed which is to check if the IC is empty. The result is displayed in the Message Box.
- **Program**
Program the data in the writer to the IC. This operation contains “Verify” function when it is executed. A “Verify” operation can also be executed later as a double check.
- **Verify**
Check if the data in the IC is the same as that in the writer. The result is displayed in the Message Box.
- **Lock**
Lock IC to prevent the data in the IC from being read out. This function is used to protect the IC data. Usually after executing the “Program” operation, the “Lock” function would be used to protect the IC data.
- **Erase**
Erase the data in the IC to make a blank IC. Currently only Flash type MCUs support this operation.
- **Read**
Read the data in the IC to the writer. After this operation, the command “Menu/File/Upload” can be executed to upload the data to the HOPE3000 for observation.
※ After the “Read” operation has been executed successfully, the data in the writer is different from that in the HOPE3000. In this condition, any programming operations are not allowed which means the buttons in the “Process” area are all disabled until the command “Menu/File/Download” is executed.
- **Smart Programming**
Start the “Smart Programming” UI. For details refer to Chapter 4 “Introduction to HOPE3000 – Smart Programming Function”.
- **Auto Upload After Read**
If this option is selected, an “Upload” operation is executed automatically after executing the “Read” operation.
- **Auto Erase Before Program**
Select this to “Erase” before “Program”. Currently only Flash type MCUs supports this option.
- **Check ID**
Select this to check if the IC type in the writer is the same as that in the opened programming file. It facilitates users to check if the IC on the adapter or the opened file is correct. Only OTP type MCUs support this option.

Other Functions

“IC Select” Dialog

This dialog (Fig. 3-12) pops up after executing the command “Menu/File/Select IC and Process”. It is used to select the required IC type for which the available selection can be either one of the two sources shown below:

- **From Recent IC**
Select from the recently used IC types. Clicking the button “Clear” removes the selected IC type from the recently used IC type list. For example, in Fig. 3-12, clicking this button will remove “HT66F50” from the list and Clicking “Clear All” will clear all types on the list.

- From All IC
Select from all the supported IC types.

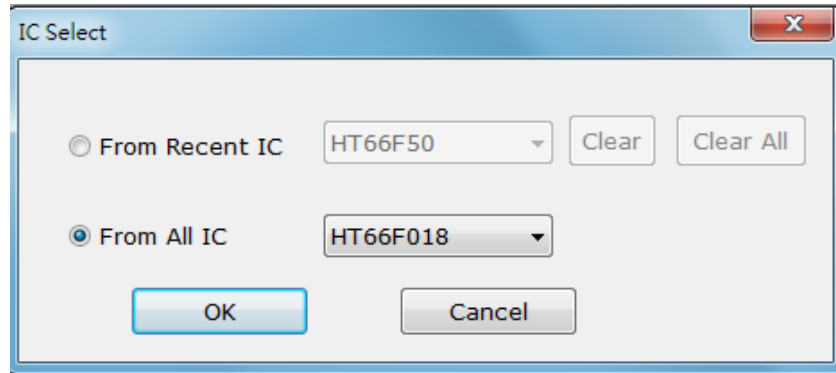

Fig. 3-12

Chapter 4 Introduction to the HOPE3000 Smart Programming Function

Smart Programming is an advanced function. Relative to the basic functions on the HOPE3000 Main UI which execute programming operations on the entire IC on the PC side, it can also execute three main functions “Auto Programming”, “Partial Programming” and “Programming User Specified Data”. On-Line Programming can be chosen to operate the writer on the PC side or Off-Line Programming can be chosen to operate the writer independently. The Smart Programming UI is divided into four main sections as shown in Fig 4-1. The following introduces the details of these sections.

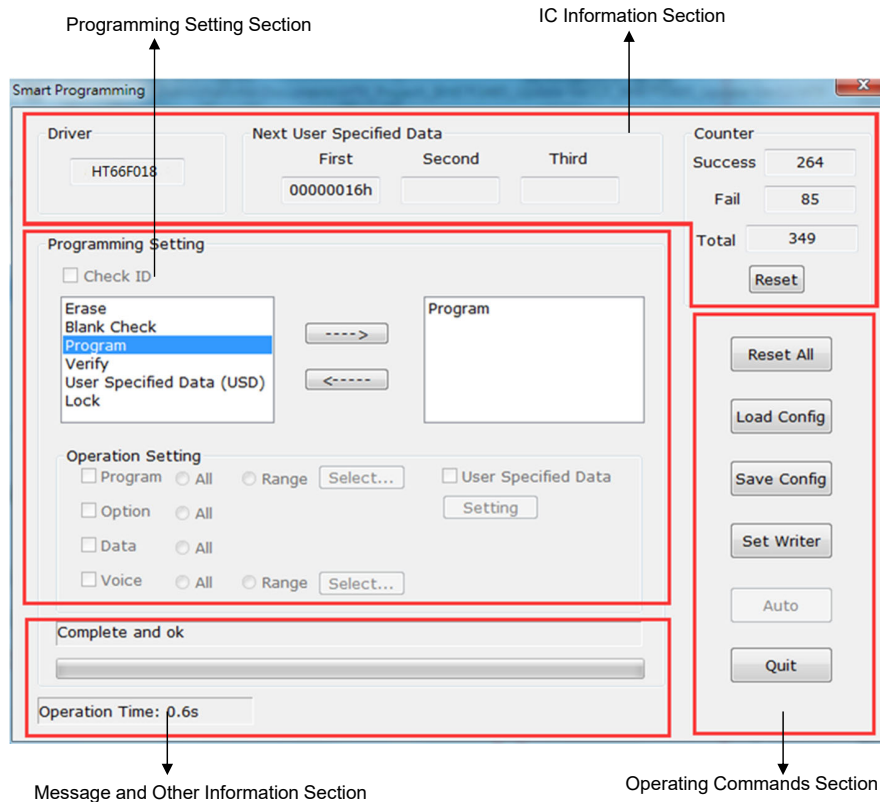

Fig. 4-1

IC Information Section

The IC Information section, as shown by the rectangle in Fig. 4-2, is divided into the following three items:

- Driver
This is the same as the field “Driver” on the HOPE3000 Main UI. It is the IC type in the opened programming file or selected using the command “Menu/File/Select IC and Process”.
- Next User Specified Data
This area shows the value of the user specified data to program. It can show three groups at the most using the “User Specified Data” dialog.
- Counter
This is the same as the field “Counter” on the HOPE3000 Main UI. It shows the successful, failed and total counts. Clicking the button “Reset” will clear these three values to zero.

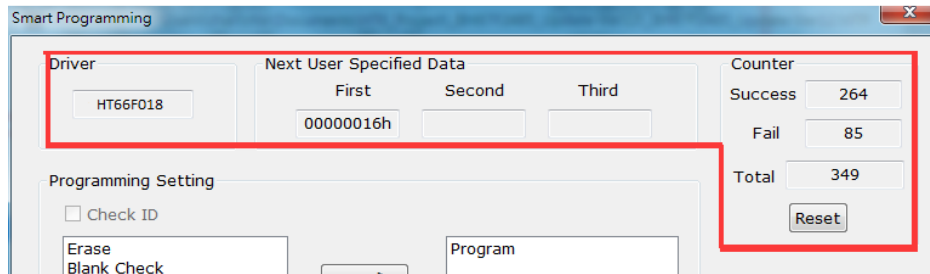

Fig. 4-2

Operating Commands Section

The Operating Commands section, as shown in Fig. 4-3, has six commands whose details are as follows:

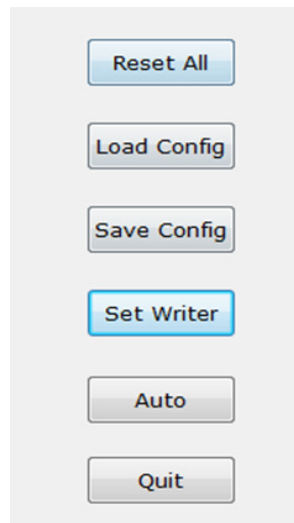

Fig. 4-3

- Reset All
Restore all the settings on the Smart Programming UI to the default settings.
- Load Config
Load the Smart Programming Configuration file (.SPC).

- Save Config
Save all the settings on the Smart Programming UI in the programming file (.SPC).
- Set Writer
Download the settings on the Smart Programming UI to the writer.
- Auto
Execute the programming operations set on the Smart Programming UI.
- Quit
Quit the Smart Programming UI and return to the HOPE3000 Main UI.

Programming Setting Section

The Programming Setting section is the section where the smart programming settings are setup. After setting, click the button “Set Writer” to download these settings to the writer. These settings can then be executed by clicking the button “Auto” (On On-Line mode) or pressing the programming key on the writer (On Off-Line mode). This section is divided into three parts as shown in Fig. 4-4 and their details are as follows.

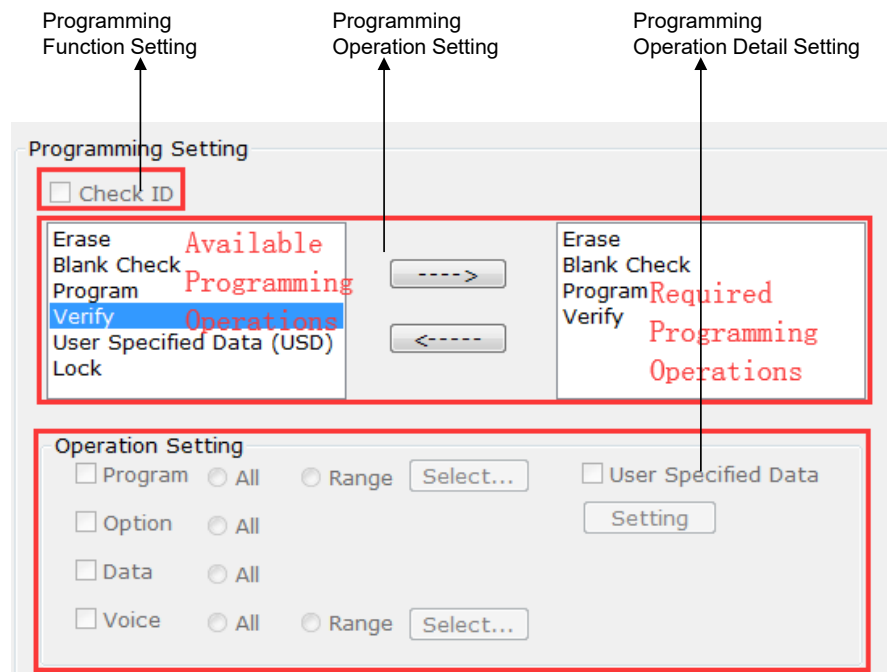

Fig. 4-4

- Programming Function Setting
This part is used for some special programming function setup and the function currently supported is:
 - ♦ “Check ID”
This is the same as the function “Check ID” on the HOPE3000 main UI. After selecting this option, the IC type on the adapter will be checked before any programming operations are executed. Only OTP MCUs support this function.
- Programming Operation Setting
This part is used to set the required programming operations with a maximum of six operations. These are “Erase”, “Blank Check”, “Program”, “Verify”, “User Specified Data” and “Lock”. Some IC types only support parts of these operations.

On the left side, the “Available Programming Operations” list lists all the supported operations. On the right side, the “Required Programming Operations” list lists all the selected operations. Clicking the button “----->” will add the the required operation from the left list to the right list and clicking the button “<-----” will remove the selected operation from the right list.

- Programming Operation Detail Setting

This part is used to set the detailed setting for each programming operation. After selecting any operation from the “Required Programming Operation” list in Fig. 4-4, the corresponding detailed settings will appear in the “Operation Setting” area on the lower side. The following explains each setting:

 - ♦ “Program”, “Option”, “Data” and “Voice”

These setting items appear when selecting the “Erase”, “Blank Check”, “Program”, “Verify” and “Lock” operations. Select the programming range of the Program, Option, Data and Voice areas. Only the Program and Voice options support partial range selection. After clicking the button “Select...”, the programming range setting window will pop up (Fig. 4-6) If any ROM setting on the UI is disabled, such as Voice as shown in Fig.4-4, it means that the IC has no ROM area for this item.

For more details refer to the “Programming Range Select Window” setion in this chapter.
 - ♦ “User Specified Data”

This setting item appears when the “User Specified Data” operation is selected. After clicking the button “Setting”, the “User Specified Data Setting Window” will pop up, as shown in Fig. 4-9. For more details refer to the “User Specified Data Setting Window” section in this chapter.

Message and Other Information Section

As shown in Fig. 4-5, this section is divided into three parts:

- Message

This shows the execution result of any operation or the writer status.
- Progress Bar

This shows the progress when setting the writer or executing auto-programming.
- Execution Time

This shows the time to execute the commands related to the writer such as “Set Writer”, “Auto” or others. This information is usually used to measure the programming time.

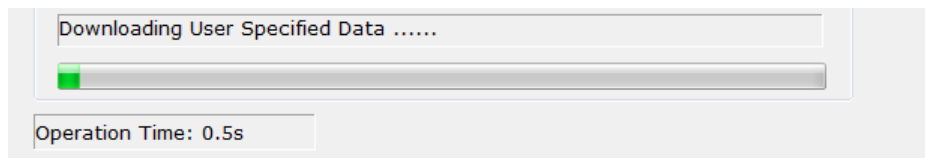

Fig. 4-5

(B) Map Mode

As shown in Fig. 4-7, this mode is suitable for applications with a larger programming range requirement. This window is divided into several parts as follows. For some items which are the same as that in the List Mode, their details will not be described again.

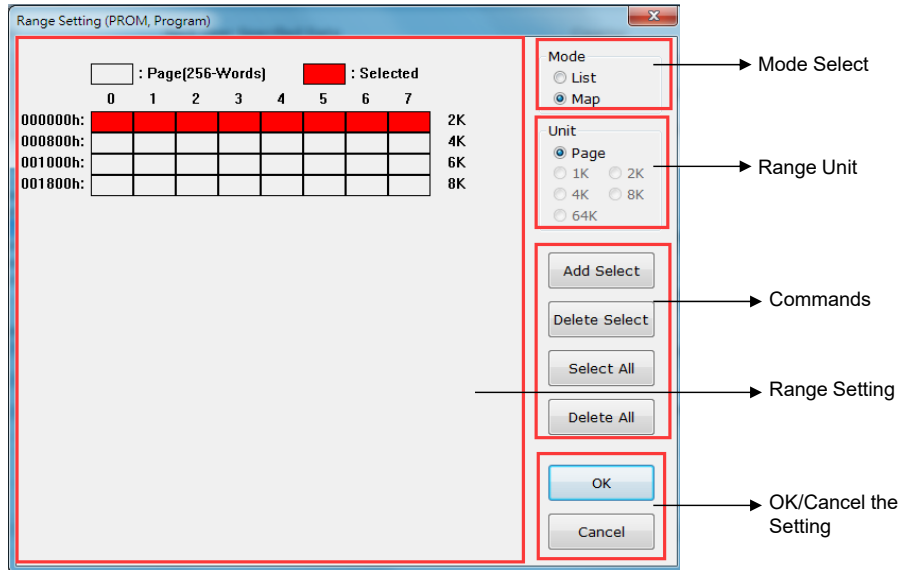

Fig. 4-7

- Range Unit
Select the unit of each grid in the “Range Setting”. According to the characteristic of the ROM section, there are five kinds of unit: Page (256 Words) for the Program ROM and 1K, 2K, 4K, 8K Bytes for the Voice ROM. As for the Data ROM (Flash), its unit is 64K Bytes.
※ When the operation is “Lock”, each grid is composed of several pages. As shown in Fig. 4-8, the red selection represents to select from page 0 to 7 and the total amount is 8 pages. In addition, there is no “List Mode” for the “Lock” operation.
- Range Setting
It lists all the programming ranges. The red range represents the selected programming range.
- Commands
“Add Select” — After clicking it, the range selected in the “Range Setting” will be added to the programming ranges.
“Delete Select” — After clicking it, the range selected in the “Range Setting” will be removed from the programming ranges.
“Select All” — Select all the programming ranges in the “Range Setting”.
“Delect All” — Delect all the programming ranges in the “Range Setting”.

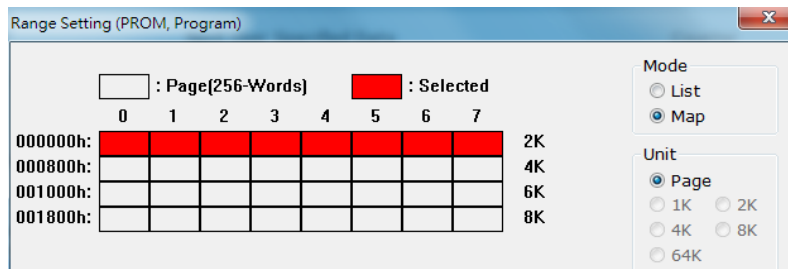

Fig. 4-8

User Specified Data Setting Window

This window is used to set the user specified data, as shown in Fig.4-9. A “User Specified Data” is a single data record to be programmed into the specified address in the ROM section. Its value is decided by the user. This function is usually applied to program serial number or other special data. It is directed at the Program Memory and EEPROM and at most three groups of different data can be programmed at one time.

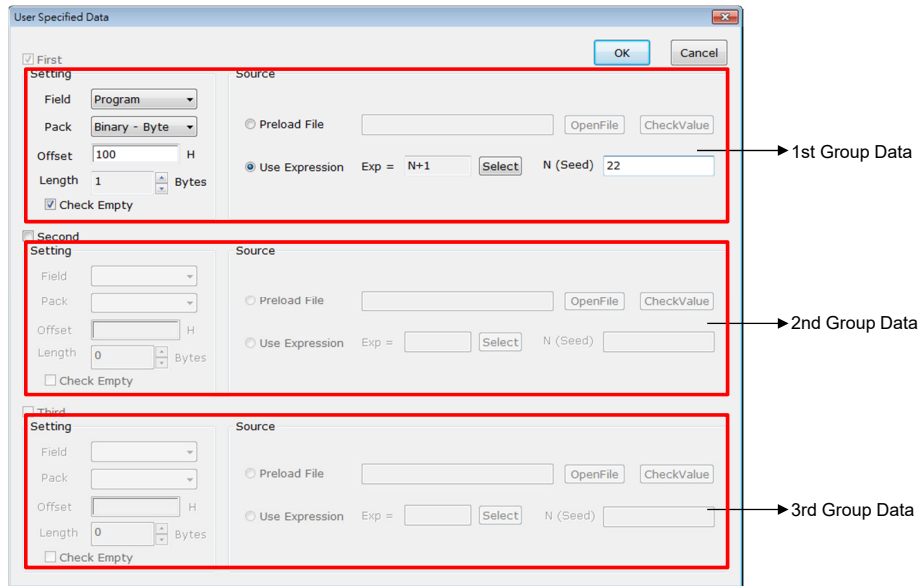

Fig. 4-9

The following introduces the definitions and how to use these settings. As shown in Fig. 4-10, each group of setting is divided into a left and a right part. The left part is used to set the form, length and address of the data in the Program Memory section and the right part is used to set the data source. The details are shown below.

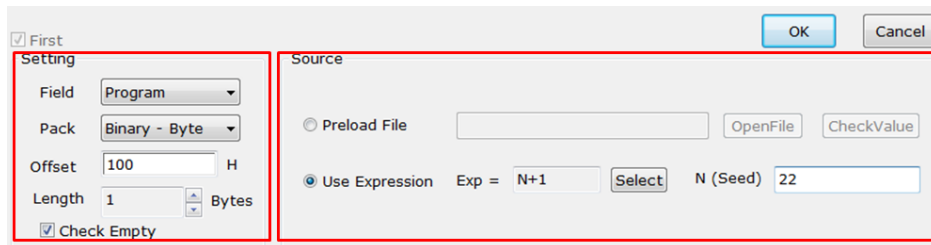

Fig. 4-10

(A) Setting – the left part in Fig. 4-10

- Field
The ROM section where data is written – now support both Program Memory and EEPROM.
- Pack
The form of the written data in the ROM section. There are following four types:
 Binary – Byte → The data is written to each low byte in a binary form (no encoding) starting from the specified address until the data length boundary is reached.
 Binary – Word → The data is written to each word in a binary form starting from the specified address until the data length boundary is reached.

BCD – Byte → The data is written to each low byte in a BCD encoded form starting from the specified address until the data length boundary is reached.

BCD – Word → The data is written to each word in a BCD encoded form starting from the specified address until the data length boundary is reached.

※ The “Binary – Word” and “BCD – Word” forms are not supported for the MCUs whose ROM bit width is less than 2 bytes (16 bits).

- Offset
The start address of the ROM section where the data is written to.
- Length
This is the length of the data. There are four options: 1, 2, 3 and 4 bytes. Any data with a length longer than the specified length will be discarded. For example, a preloaded data is 12345678H but with a specified data length of 3 bytes, only 345678H will be valid for this data record.
- Check Empty
First check if the programming range is empty before programming this data record. If not empty, an error message will be shown during the programming.

The following shows two practical setting examples:

Example 1. For a data record of 345678H and a length of 3 bytes, programmed from the start address of 100H in the Program Memory with a Binary – Byte form, the actual programming condition will be:

100H → 0078H
101H → 0056H
102H → 0034H

Example 2. For a data record of 12345678H (BCD code is 305419896H) and a length of 4 bytes, programmed from the start address of 200H in the Program Memory with a BCD – Word form, the actual programming condition will be:

200H → 9896H
201H → 0541H

(B) Data Source – the right part in Fig. 4-10

※ “Preload File” has a restriction whereby the total data record count is about 900 records. However, “Use Expression” does not have this restriction.

- Preload File
Taking the values in the file (include several user-specified data records) as the user specified data. The file can have one of the following formats:
 - ♦ “.BIN” — Binary file. Each N-Byte number in a file is considered as one user specified data record where N is the specified data length.
For example, if the data (hexadecimal number) in a file is: 12 34 56 78 9A BC CD and the specified data length is 3 bytes.
Then the 1st record of data is 563412H,
the 2nd record of data is BC9A78H,
the 3rd record of data is 0000CDH (fill 0 for the insufficient part).
 - ♦ “.TXT” — Text file. The number in each line of the file is considered as one user specified data record which can be binary, decimal or hexadecimal.
For example, if the number in a file is 123456789H
10000000B
55555

and the specified data length is 2 bytes.

Then the 1st data record is 6789H (the exceeding part is abandoned),
 the 2nd data record is 0080H,
 the 3rd data record is D903H.

Usage — as shown in Fig. 4-11, click the button “OpenFile” to load the file. In addition, click the button “CheckValue” to check each generated data record, as shown in Fig. 4-11.

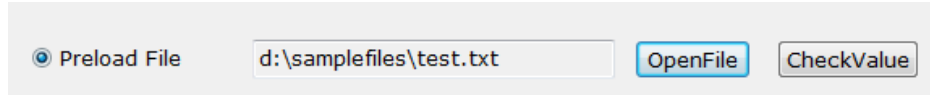

Fig. 4-11

- Use Expression

The specified data source comes from the calculation result of a mathematical polynomial. The result of each calculation is the value of N for the next record. It supports two expressions “N+1” and “N-1”.

- ♦ Use the expression “N+1” or “N-1”: the data is generated from the expression “N+1” or “N-1”. It is only necessary to set the initial value of N to generate any amount of data records. This is well suited for applications that require a high quantity of data records not from the calculation of a complicated expression. Note that it does not detect an “N+1” overflow or an “N-1” underflow.

Usage — First click the “Select” button to select the expression as shown in Fig. 4-13 and then fill the initial value of N on the location “N (Seed)”.

※ As the setting shown in Fig. 4-12, the generated data will be 1, 2, 3, 4, 5.....

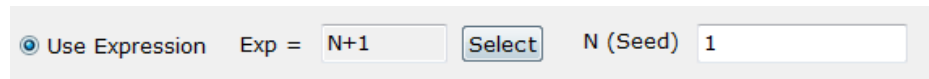

Fig. 4-12

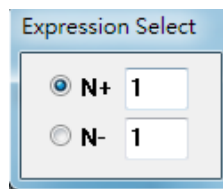

Fig. 4-13

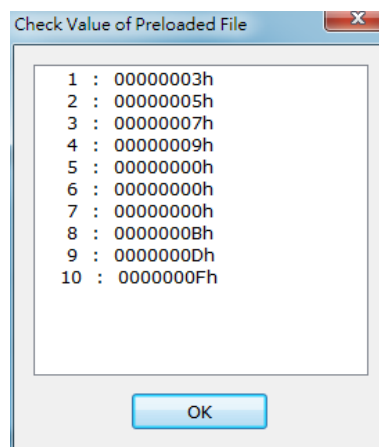

Fig. 4-14

Chapter 5 Introduction to HOPE3000 – DOS Command Mode

The HOPE3000 – DOS Command Mode controls the writer using the command method. That is to type the command in the “Command Prompt” program under MS Windows to implement the programming. To start this mode, refer to Case.7 in the Chapter 2 “Quick Start”.

Features

- Compatible with the DOS-Shell command format
The parameter format of all the integrated commands is compatible with that of the DOS-Shell commands. Users can write a batch file (.BAT) with any combination of the commands.
- All commands and their parameters are case-insensitive.
- On-Line Help: add “/?” to the end of each command to show the command description
e.g. C:\>WCMD /? ; Get the descriptions of all the supported commands
C:\>WCMD -D /? ; Get the description of the Download command

Command List

Command Format:

C:\>WCMD -Command /Parameter

e.g. C:\>WCMD -D /FC:\HT45F0V.MTP /W2

The available commands and their parameter definitions are listed as follows.

1) [T] Obtain the writer number

Syntax: -T [/WWriterNumer]

Parameter: WriterNumer – the specified writer number (1~8); if not specified, default value is 1

Remarks: 1. This command is used to identify the number of each writer.

2. All the three LEDs on the writer will flash when this command is executed.

3. When using multiple writers, identify the number of each writer using this command first. If only one writer is used, this command is not necessary.

Examples: -T ; Identify the number 1 writer

-T /W2 ; Identify the number 2 writer

2) [D] Download a file to writer

Syntax: -D /FFilePathName [/MMCType] [/KPackageName] [/LUpLoad] [/WWriterNumber]

Parameters: FilePathName – specifies the path and name of the file to be downloaded

MCUType – specifies the MCU type when opening the .MEM file

PackageName – specifies the MCU package. This parameter is necessary when using the e-WriterPro.

UpLoad – specifies whether users can upload the downloaded programming data into the writer or not. The value “1” represents CANNOT and the value “0” represents CAN.

WriterNumer – the specified writer number (1~8), if not specified, default value is 1

Remarks: 1. FilePathName can support the .MEM file (binary file) to independently program the EEPROM section of the MCU.

2. To obtain all the PackageName of the specified IC, use the command “K”.

Examples: -D /FC:HT45F0V.MTP
 -D /FC:HT46F47E_EEDATA.MEM /MHT46F47E
 -D /FC:HT66F50E.MTP /K28SKDIP-A ; When using the e-WriterPro
 -D /FC:HT66F50E.MTP /K28SKDIP-A/L1 ; Prohibit to upload

3) [U] Upload data from writer to PC and save it as a file

Syntax: -U [FFFilePathName] [/WWriterNumber]

Parameters: FilePathName – specifies the file path name to store file (it's not necessary to specify the file extension name, the program will use the file type stored in the writer); if not specified, the file name stored in the writer will be used.

WriterNumber – the specified writer number (1~8); if not specified, default value is 1

Examples: -U /FC:\UploadFile
 -U /W3

4) [P] Program IC with data in the writer (Program)

Syntax: -P [/PROMType0=StartAddress-EndAddress,ROMType1,...ROMType3]
 [/WWriterNumber]

Parameters: ROMType – the ROM section to be written. It must be “Program”, “Option”, “Data” or “Voice”.

StartAddress – the start address to program data (for partial programming)

EndAddress – the end address to program data (for partial programming)

WriterNumber – the specified writer number (1~8); if not specified, default value is 1

Remarks: 1. Only “Program” and “Voice” support the partial programming function.

2. If no range is specified, it would be all ROM sections.

3. Before using this command, ensure that the programming file has been downloaded to the writer.

4. When executing this command, it reads the data programmed into the IC and verifies it to ensure the programming is successful.

Examples: -P ; Program all ROM sections
 -P /PProgram=100h-2FFh,Option ; Program partial PROM, all Option ROM
 -P /PData,Voice=2000h-3FFFh ; Program partial Voice ROM, all Data ROM
 -P /PProgram,Voice ; Program all PROM, Voice ROM

5) [V] Verify IC with data in writer (Verify)

Syntax: -V [/VROMType0=StartAddress-EndAddress,ROMType1,...ROMType3]
 [/WWriterNumber]

Parameters: ROMType – the ROM section to be verified. It must be “Program”, “Option”, “Data” or “Voice”.

StartAddress – the start address to be verified (for partial verification)

EndAddress – the end address to be verified (for partial verification)

WriterNumber – the specified writer number (1~8); if not specified, default value is 1

Remarks: 1. Only “Program” and “Voice” support the partial verification function.

2. If no range is specified, it would be all ROM sections.

3. Before using this command, ensure that the programming file has been downloaded to the writer.
4. “P” command (Program) contains the verify function, users can execute this “V” command later for a double check. If there is no requirement for a double check, it is not necessary to use this command. Refer to the example 2 in the last section of this chapter.

Examples: -V

```
-V /VProgram=100h-2FFh,Option  
-V /VData,Voice=2000h-3FFFh  
-V /VProgram,Voice
```

6) [B] Check if IC is blank (Blank Check)

Syntax: -B [/BROMType0=StartAddress-EndAddress,ROMType1,...ROMType3]
[/WWriterNumber]

Parameters: ROMType – the ROM section to be checked. It must be “Program”, “Option”, “Data” or “Voice”.

StartAddress – the start address to be checked (for partial blank check)

EndAddress – the end address to be checked (for partial blank check)

WriterNumber – the specified writer number (1~8); if not specified, default value is 1

Remarks: 1. Only “Program” and “Voice” support the partial blank check function.

2. If no range is specified, it would be all ROM sections.
3. Before using this command, ensure that the programming file has been downloaded to the writer.
4. Executing this command will get the information that whether the IC is empty or not. If there is no requirement for this information during the programming process, it is not necessary to use this command. Refer to the example 2 in the last section of this chapter.

Examples: -B

```
-B /BProgram=100h-2FFh,Option  
-B /BData,Voice=2000h-3FFFh  
-B /BProgram,Voice
```

7) [E] Erase IC (Erase)

Syntax: -E [/EROMType0=StartAddress-EndAddress,ROMType1,ROMType2]
[/WWriterNumber]

Parameters: ROMType – the ROM section to be erased. It must be “Program”, “Option”, “Data” or “Voice”.

StartAddress – the start address to be erased (for partial erasing)

EndAddress – the end address to be erased (for partial erasing)

WriterNumber – the specified writer number (1~8); if not specified, default value is 1

Remarks: 1. Only “Program” and “Voice” support the partial erasing function. “Voice” erase is only available for the Flash Type Voice MCUs.

2. If no range is specified, it would be all ROM sections.

- Before using this command, ensure that the programming file has been downloaded to the writer.

Examples: -E

```
-E /EProgram=100h-2FFh,Option
-E /EData
-E /EProgram
```

8) [L] Lock IC (Lock)

Syntax: -L [LROMType0=StartAddress-EndAddress,ROMType1] [/WWriterNumber]

Parameters: ROMType – the ROM section to be locked. It must be “Program” or “Data”.

StartAddress – the start address to be locked (for partial lock)

EndAddress – the end address to be locked (for partial lock)

WriterNumber – the specified writer number (1~8); if not specified, default value is 1

- Remarks:
- Only “Program” supports partial lock function.
 - If no range is specified, it would be all ROM sections.
 - Before using this command, ensure that the programming file has been downloaded to the writer.

Examples: -L

```
-L /LProgram=0h-3h,Data
-L /LProgram
```

9) [R] Read data in IC to writer (Read)

Syntax: -R [/WWriterNumber]

Parameter: WriterNumber – the specified writer number (1~8); if not specified, default value is 1

- Remarks:
- No partial read.
 - Before using this command, ensure that the programming file has been downloaded to the writer.

Example: -R

10) [S] Set settings for Auto-Programming

Syntax: -S [EROMType0=StartAddress-EndAddress,ROMType1,ROMType2] ; Erase
 [BROMType0=StartAddress-EndAddress,ROMType1,...ROMType3] ; Blank Check
 [PROMType0=StartAddress-EndAddress,ROMType1,...ROMType3] ; Program
 [VROMType0=StartAddress-EndAddress,ROMType1,...ROMType3] ; Verify
 [LROMType0=StartAddress-EndAddress,ROMType1] ; Lock
 [UPackType-StartAddress-LengthType-CheckBlank-SourceType-
 SourceTypeParam1.....SourceTypeParamN, PackType-..., PackType-...]
 ; User Specified Data
 [/WWriterNumber]

Parameters: Prefix “/U” – represents to set the user specified data. Each group of data setting is separated with “,” and it supports at most three groups of data.

PackType – The form of the data written into the ROM section. There are four types:

“0” represents Binary – Byte

“1” represents Binary – Word (Only for ICs with 16-bit width ROM)

“2” represents BCD – Byte

“3” represents BCD – Word (Only for ICs with 16-bit width ROM)

StartAddress – The start address of the ROM section where data is written to.

LengthType – The data length. There are four selections: 1, 2, 3 and 4 bytes.

CheckBlank – Whether to execute BlankCheck before programming. “1” represents YES, “0” represents NO.

SourceType – The data source. There are two types. If the source is different, the number of the follow-up SourceTypeParam is also different.

“0” represents “Preload File”. SourceTypeParam1 is the file name.

“1” represents “Use Expression”. SourceTypeParam1 is the expression selection,

“0” stands for “N+1”, “1” stands for “N-1”. SourceTypeParam2 is N (Seed).

Refer to the “User Specified Data Setting Window” in the Chapter 4 for more details.

Refer to the command “E”, “B”, “P”, “V”, “L” for their command definitions and other parameter descriptions.

- Remarks:
1. This command stores the settings into the writer. These settings are executed when using the “A” command.
 2. Blank Check, Program and Verify should use the same range and users only need to set the range once (see example).
 3. Before using this command, ensure that the programming file has been downloaded to the writer.

Examples:

```
-S /EProgram=100h-2FFh /B/P/VProgram=100h-2FFh ; Erase/blank check/program/verify
; 100h~2FFh of PROM
-S /B/P/VOption,Data /LData ; Blank check /program/verify Option and Data ROM,
; and lock Data ROM
-S ; Set all operations and all ROM sections (except for User Specified Data)
-S /U0-100H-1-1-0-C:USD.BIN, 1-00H-2-1-2-0-20, 1-00H-2-1-1-0-20
; Program User Specified Data which contains three groups
; 1st group setting: Pack type is Binary-Byte, Start Address is 100H, Data Length is 1 byte,
; execute BlankCheck before programming, Data Source is Preload File,
; its file path is “C:\USD.BIN”
; 2nd group setting: Pack type is Binary-Word, Start Address is 0H, Data Length is 2 bytes,
; execute Blank Check before programming, Data Source is Using Expression,
; use “N+1” expression and N (Seed) is 20
; 3rd group setting: Same as the 2nd group setting
```

11) [A] Run Auto-Programming

Syntax: -A [/WWriterNumber]

Parameter: WriterNumber – the specified writer number (1~8); if not specified, default value is 1

Remark: Before using this command, first set settings using the “S” command.

Example: -A

12) [W] Write IC directly with a specified value

Syntax: -W /PROMType=StartAddress:Value [/WWriterNumber]

Parameters: ROMType – The ROM section to be written to. It must be “Program” or “Data”.

StartAddress – The start address to be written.

Value – The hexadecimal value to write (at most 16 words long).

WriterNumber – the specified writer number (1~8); if not specified, default value is 1

Remark: Before using this command, ensure that the programming file has been downloaded to the writer.

Examples: -W /PProgram=100h:01234567h

-W /PData=02h:24959h /W2

13) [C] Get the ROM checksum from the programming file

Syntax: -C /FFilePathName [/RROMRangeFlag]

Parameters: FilePathName – the programming file path name

ROMRangeFlag – Select the ROM sections to calculate checksum.

“1” represents Program ROM

“2” represents Program ROM + Option ROM

“3” represents Program ROM + Option ROM + Data (or Voice) ROM and the default value is 3

Remark: This command returns the ROM checksum value and shows it on the screen.

Example: -C /FC:\HT45F0V.MTP /R2

14) [K] Get all the package names of IC

Syntax: -K /MMCUType

Parameter: MCUType – IC name

Remark: This command returns all the package names of the specified IC and shows them on the screen, one line showing one package name.

Example: -K /MHT66F50

15) [CON] Enter the console mode

Syntax: -CON

Remarks: 1. This command is used to enter the Console mode under the Dos Command Mode.

2. After entering this mode, users do not need to manually input the front “-” when using the above commands.

3. In the console mode, users are allowed to input multiple commands above. After a Q command is executed, the program will exit the console mode and return to the Dos mode.

4. In the console mode, command execution time can be reduced.

5. Refer to Example 6 for specific usage.

Example: C:\>WCMD -CON

16) [Q] Exit the program

Syntax: -Q

Remark: This command can only be used in the console mode to exit the console mode and return to the Dos mode.

Example: -Q

Examples

Example 1. Select the writer (when there are multiple writers) and program the IC.

```
WCMD -T /W1
WCMD -T /W2
WCMD -D /FC:\HT45F0V.MTP /W2
WCMD -E /W2
WCMD -B /W2
WCMD -P /PProgram=100h-200h,Option,Data /W2
WCMD -V /VProgram=100h-200h,Optiion,Data /W2
WCMD -W /PProgram=201h:334455h /W2
WCMD -L /W2
```

Example 2. It's purpose is the same as example 1 but skipping the B (blank check) and V (verify) commands to speed up the programming process.

```
WCMD -T /W1
WCMD -T /W2
WCMD -D /FC:\HT45F0V.MTP /W2
WCMD -E /W2
WCMD -P /PProgram=100h-200h,Option,Data /W2
WCMD -W /PProgram=201h:334455h /W2
WCMD -L /W2
```

Example 3. Read data from the IC to PC and save it as a file.

```
WCMD -R
WCMD -U /FC:\ReadData
※ The data in the writer must be the same as that of the IC.
```

Example 4. Auto programming.

```
WCMD -D /FC:\HT46F46E.MTP
WCMD -S /EProgram=0h-2FFh,option,data /B/P/VProgram=0h-2FFh,option,data
/LProgram=0h-2FFh,data
WCMD -A
```

Example 5. Auto programming (contains programming User Specified Data to Program) using the e-WriterPro

```
WCMD -D /FC:\HT66F30.MTP /K16DIP-A
WCMD -S /E/B/P/V /U0-00H-1-1-1-2+1-10
WCMD -A
```

Example 6. Auto programming (contains programming User Specified Data to EEPROM) using the e-WriterPro

```
WCMD -D /FC:\HT66F30.MTP /K16DIP-A
WCMD -S /E/B/P/V /UDATA=0-00H-1-1-1-2+1-10
WCMD -A
```

Example 7. Console mode, using the e-WriterPro

```
WCMD -CON
-T /W1
-K /MHT66F50
-D /FC:\HT66F50.MTP /K28SKDIP-A /W1
-E /W1
-P /W1
-V /W1
-Q
```

Appendix A System and Writer Error Messages

System Error Messages

- ERR_0001: No language file found !
The HOPE3000 language file is missing, reinstall the HOPE3000.
- ERR_0002: Error occurred when loading language file !
Cannot load the HOPE3000 language file. Reboot the PC and then run the HOPE3000 again. If the error occurs again, reinstall the HOPE3000.
- ERR_0003: Failed to find
Cannot find the specified file. Check whether the file exists, whether the specified path is correct or whether it is being used by another program.
- ERR_0004: Invalid file format or failed to find driver !
The opened file format is invalid or the IC type in the file is not supported. Check if the programming file is generated from the HT-IDE3000 or other Holtek official software and that the version of the HOPE3000 supports that IC type. Check this by referring to the document "Supported IC List" in the "Manual" directory under the root directory of the HOPE3000.
- ERR_0005: Failed to load the data in the writer ! Download the file again.
Unable to upload because the data in the writer is damaged or for some other reasons. Download the programming file again.
- ERR_0006: Find no EFORMATtoDDF.DLL !
System file is missing. Reinstall the HOPE3000 program.
- ERR_0007: Load EFORMATtoDDF.DLL failed !
Cannot load the HOPE3000 system file. Reboot the PC and execute the HOPE3000 again. If the error occurs again, reinstall the HOPE3000.
- ERR_0008: Find no DLLFORFUN.DLL !
The system file is missing, reinstall the HOPE3000.
- ERR_0009: Load DLLFORFUN.DLL failed !
Cannot load the HOPE3000 system file. Reboot the PC and execute the HOPE3000 again. If the error occurs again, reinstall the HOPE3000.
- ERR_0010: Invalid SPC file format !
The opened Smart Programming Configuration file (.SPC) format is incorrect. Ensure that this file has been generated by the HOPE3000.
- ERR_0011: This SPC file version cannot be used in this program version !
The version of the opened Smart Programming Configuration file (.SPC) is not supported for this

version of the HOPE3000. Use the proper HOPE3000 version to open this file or set the Smart Programming Configuration again.

- **ERR_0012: Driver type mismatched !**
The driver type in the opened Smart Programming Configuration file (.SPC) is different from the currently used driver type. Ensure that this .SPC file is correct.
- **ERR_0024: Save file failed !**
Fail to save file. Reboot the PC and execute the HOPE3000 again.
- **ERR_0025: Download language file to console failed !**
Fail to download the language file to Console. Check if the Console is connected to the writer then reboot the PC and execute the HOPE3000 again. If the error occurs again, reinstall the HOPE3000.
- **ERR_0026: Download driver failed !**
The driver download has failed. Reboot the PC and execute the HOPE3000 again. If this error occurs again, reinstall the HOPE3000.
- **ERR_0027: The data in the writer is invalid ! Download the file again.**
The data uploaded is invalid because the data in the writer is damaged or for some other reasons. Download the programming file again.
- **ERR_0028: The specified IC is invalid !**
The HOPE3000 cannot identify the specified IC type. Reboot the PC and execute the HOPE3000 again. If the error occurs again, reinstall the HOPE3000.
- **ERR_0029: The driver type in the writer is not supported !**
This version of the HOPE3000 does not support this driver type (IC type) uploaded from the writer. Use the version of the HOPE3000 that supports this driver type to upload again.
- **ERR_0030: Find or load driver failed !**
Error occurred when loading the driver. Reboot the PC and execute the HOPE3000 again. If the error occurs again, reinstall the HOPE3000.
- **ERR_0031: ROM data checksum error !**
The data uploaded is invalid because the data in the writer is damaged or for some other reasons. Download the programming file again.
- **ERR_0032: Obtain next user specified data failed !**
Cannot obtain the next user specified data. Reboot the PC and writer and then execute the HOPE3000 again.
- **ERR_0034: Not supported F/W version !**
This version of the HOPE3000 cannot support this writer F/W version. Use the proper HOPE3000 version that supports this F/W version.
- **ERR_0035: Find or Load HDumpOpt32.DLL Failed !**
Lose the system file or fail to load it. This error results in the "Option Viewer" function not being executed. Reboot the PC and then execute the HOPE3000 again. If the error occurs again, reinstall the HOPE3000.
- **ERR_0036: Find or Load DllForUI.DLL Failed !**
Lose the system file or fail to load it. Reboot the PC and then execute the HOPE3000 again. If the error occurs again, reinstall the HOPE3000.
- **ERR_0037: Find no HOPrint32.EXE !**
Lose the system file or fail to load it. This error results in the "Option Viewer" function not being executed. Reboot the PC and then execute the HOPE3000 again. If the error occurs again, reinstall the HOPE3000.

- ERR_0038: Update F/W Failed ! (SID-XX)
Error occurred when updating the F/W. Reboot the PC and then execute the HOPE3000. If the error occurs again, reinstall the HOPE3000. If the problem occurs again, contact an agent or Holtek for further help. Provide the SID number in the error message.
- ERR_0039: Invalid F/W ! Please execute "Menu\Tool\F/W Update" firstly !
The writer F/W is invalid. Execute "Menu\Tool\F/W Update" to update the F/W firstly.
- ERR_0040: The selected IC package in the writer is not supported !
The IC package in the writer is not supported in this version of the HOPE3000. Select another package.
- ERR_0041: Find or Load ToolRegProcess.DLL Failed !
Cannot load the HOPE3000 system file. Reboot the PC and then execute the HOPE3000 again. If the error occurs again, reinstall the HOPE3000.

Writer Error Messages

Most errors occurred on the writer result from the incorrect operation of the hardware. In the first instance take note of the following points:

- Check that the writer is properly connected – connect to the PC for the On-Line mode or to a power adapter for the Off-Line mode.
- Check that the programming adapter type is correct.
- Check that the IC is properly located in the programming adapter and the bar is pulled down and the IC type is correct.
- Try a different IC to check if the problem still occurs.
- For the problem still occurs, reboot the PC, power on the writer and try again.

The following are the writer error messages and their explanations:

- Chip ID is Mismatched
The IC type put on the writer is different from that in the opened file. Ensure that the IC put on the writer is correct.
- Chip is not Blank
The IC has been programmed.
- Program Error
Error occurred during programming.
- Verify Error
The data in the IC is different from the data in the writer.
- Lock IC Error
Error occurred when locking the IC.
- Read Error
Error occurred when reading the IC.
- Writer User Data Error
Examination of the programming data failed when the writer powers on. Download the programming data again.
- Smart Programming has not been set yet
No auto programming operations have been set therefore no Off-Line programming is possible. Enter the Smart Programming Setting window to set auto programming operations.
- Erase Error
Error occurred when erasing the IC.

- Download to Writer Error
Error occurred when downloading the programming file from the PC to the writer.
- Upload to PC Error
Error occurred when uploading the programming file from the writer to the PC.
- User Specified Data Exceeded
The user specified data has exceeded. Set again the user specified data.
- Program Error (Trim HIRC Fail)
The HIRC trim error occurred during programming. Check whether the programming pins ICPCCK and ICPDA have connected a capacitor larger than 220pf or a large load component and check whether the VDD power (5V or 3V) is stable.
- Writer Flash Timeout
The writer flash does not respond during downloading. Download the data again. If the problem occurs again, contact an agent or Holtek for further help.
- Writer F/W is too old
The F/W version of the writer is too old to use with this version of the HOPE3000. Contact with an agent or Holtek to update the F/W.
- Chip is Locked
The IC is locked. No programming operation can be executed except for "Erase".
- Test Flash Error
A writer hardware error occurred during downloading. Download the data again. If the problem occurs again, contact an agent or Holtek for further help.
- The address in the IC where the user specified data to be written is not empty
Check if the IC is empty or if the user specified data setting is correct.
- Enter Programming Mode Error
Error occurred when entering the programming mode. Check if the IC is correct.
- Data Checksum Error
Data check error occurred when uploading or downloading. Download the data again.
- Writer System Data Error
Examination of the system data failed when the writer powers on. Download the programming data again.
- Hardware (Flash) Error
Examination of the writer hardware failed when powers on. Contact an agent or Holtek for further help.
- Hardware (Power) Error
Hardware error occurred during programming. Check if the IC and the programming adapter are correct and properly placed. If the problem occurs again, contact an agent or Holtek for further help.
- Power Error! Please Re-power on the Writer
Error occurred on the writer power. Power on the writer and try again.
- Timeout
Writer has timed out, power on the writer again.
- Writer is Busy
Writer is busy, power on the writer again.

Appendix B Writer LEDs and Status

The writer supplies three LEDs to represent the programming results by LED light status.

The status of each LED is:

- ON: LED is turned on
- OFF: LED is turned off
- Fast Flash: LED flashes for each 0.25s
- Slow Flash: LED flashes for each 0.5s

Table B-1 lists the definitions of various flashing states of each LED light.

Blue LED (OK)	Yellow LED (Ready/Busy)	Read LED (Fail)	Definition
During Writer Power On			
ON	Slow Flash	ON	Check the power when the writer powers on.
Slow Flash	Slow Flash	ON	The writer power is damaged.
OFF	Slow Flash	OFF	The writer power is OK.
OFF	Slow Flash	ON	The Flash in the writer is damaged.
OFF	Slow Flash	OFF	Power on OK. Standalone (Smart) Programming Setting has been set and Standalone Programming is available.
OFF	OFF	Slow Flash	Power on OK. Standalone (Smart) Programming Setting has NOT been set and Standalone Programming is NOT available.
Fast Flash	OFF	Fast Flash	User specified data has exceeded.
During Normal Operation			
Slow Flash	Slow Flash	ON	The writer power is damaged.
OFF	Fast Flash	OFF	The programming operation is being executed (Busy).
Slow Flash	OFF	OFF	Operation is OK or the writer is standby.
OFF	OFF	Slow Flash	Operation has failed
Fast Flash	Fast Flash	Fast Flash	This status is used to indentify the writer number when multiple writers are used.
Fast Flash	OFF	Fast Flash	User specified data has exceeded.

Table B-1

Appendix C e-WriterPro ICP Pin Definitions and ICP Considerations

e-WriterPro ICP Pin Definitions

Table C-1 lists all kinds of ICP packages and the corresponding pin definitions. The following two steps introduce how to obtain the required pin definition.

Step 1. Obtain the ICP type for the MCU being used:

(Refer to the Holtek website: Home → MCU Tools → MCU Tools Index Table)

All 8-bit MCUs (including V2 flash MCUs) use the e-WriterPro & e-socket for programming.

8-bit Series MCU Tools				
Device Part No.	ICE Type	Tool Part No.	Programming Timing	ICP Type
BS83B08-3, BS83B12-3, BS83B16-3	e-ICE	M1001D + D1023A	Flash Type-6	ICP-2B
BS85B12-3	e-ICE	M1001D + D1033A	Flash Type-6	ICP-2B
BS85C20-3	e-ICE	M1001D + D1036A	Flash Type-6	ICP-2B
HT37A20, HT37A30, HT37A40, HT37A50, HT37A60, HT37A70	Demo Board	HT-VMS-MB	--	--
HT37B30, HT37B50, HT37B70	Demo Board	HT-VMS-MB	--	--
HT37Q20, HT37Q30, HT37Q40, HT37Q50, HT37Q60, HT37Q70	Demo Board	HT-VMS-MB	--	--
HT45F23, HT45F43	e-ICE	M1001D + D1034A	Flash Type-6	ICP-2B
HT45FM03B	HT-ICE(S)	CICE45FM03B08B	Flash Type-6	ICP-2B

Fig. C-1

Step 2. Obtain the pin definitions of each ICP type from this table.

ICP Type	ICP Package on HOPE3000	ICP Pin Definition Link
ICP-1A	ICP (e-CON12B)	ICP-1A
ICP-1B	ICP (e-CON12B)	ICP-1B
ICP-1C	ICP (e-CON12B)	ICP-1C
ICP-1D	ICP (e-CON12B)	ICP-1D
ICP-1E	ICP (e-CON12B)	ICP-1E
ICP-1F	ICP (e-CON12B)	ICP-1F
ICP-2A	ICP (e-CON12C)	ICP-2A
ICP-2B	ICP (e-CON12C)	ICP-2B
ICP-2C	ICP (e-CON12C)	ICP-2C

Table. C-1

1) ICP-1A

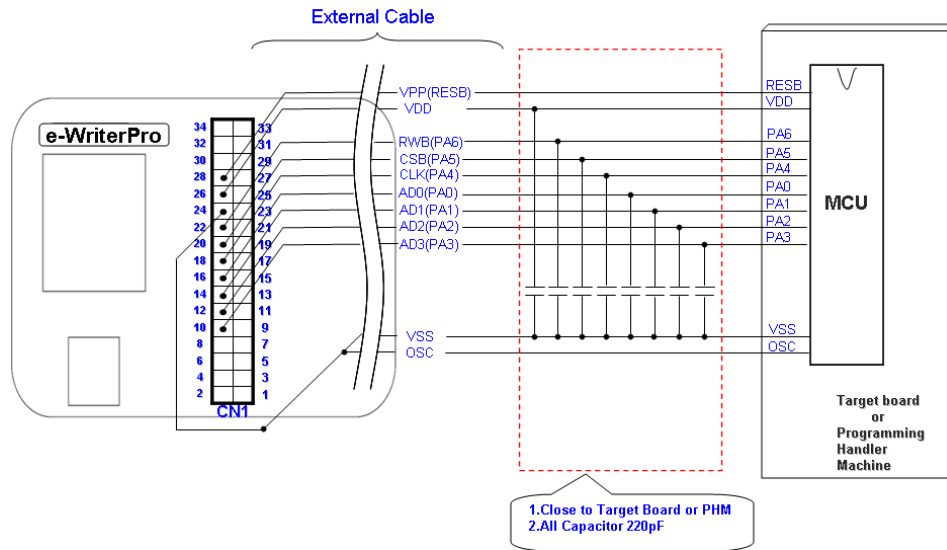

Fig. C-2

2) ICP-1B

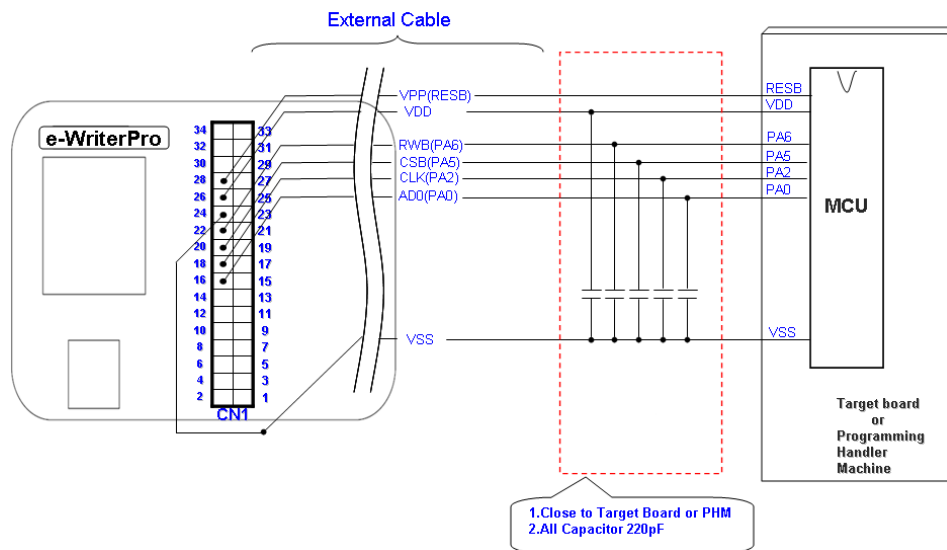

Fig. C-3

3) ICP-1C

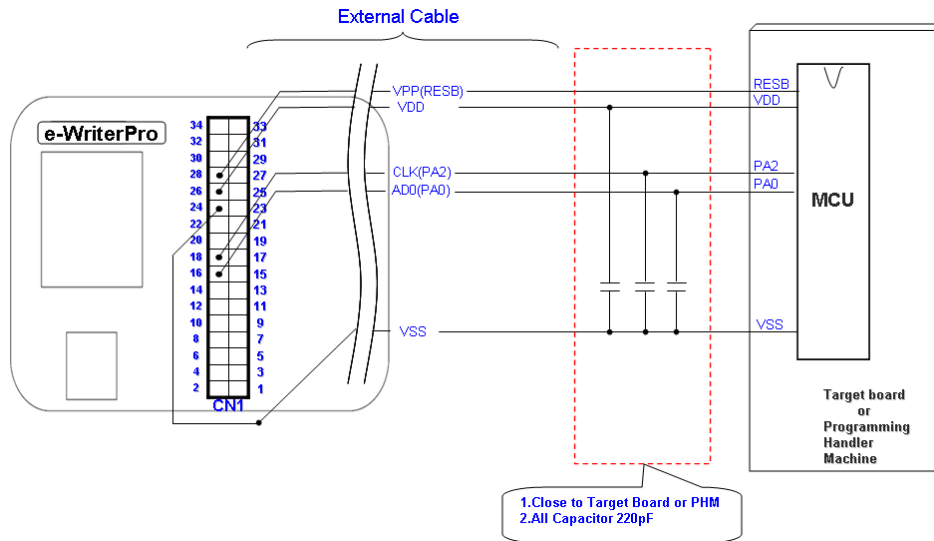

Fig. C-4

4) ICP-1D

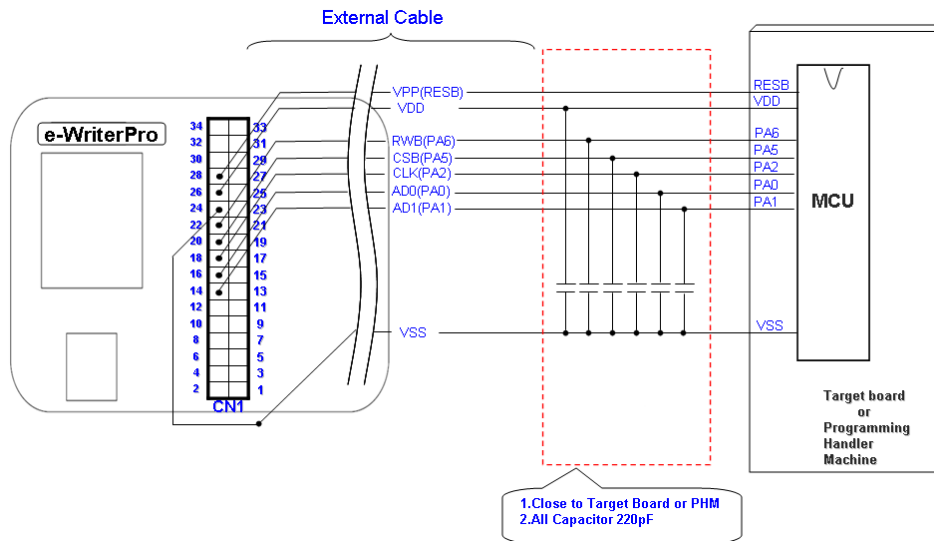

Fig. C-5

5) ICP-1E

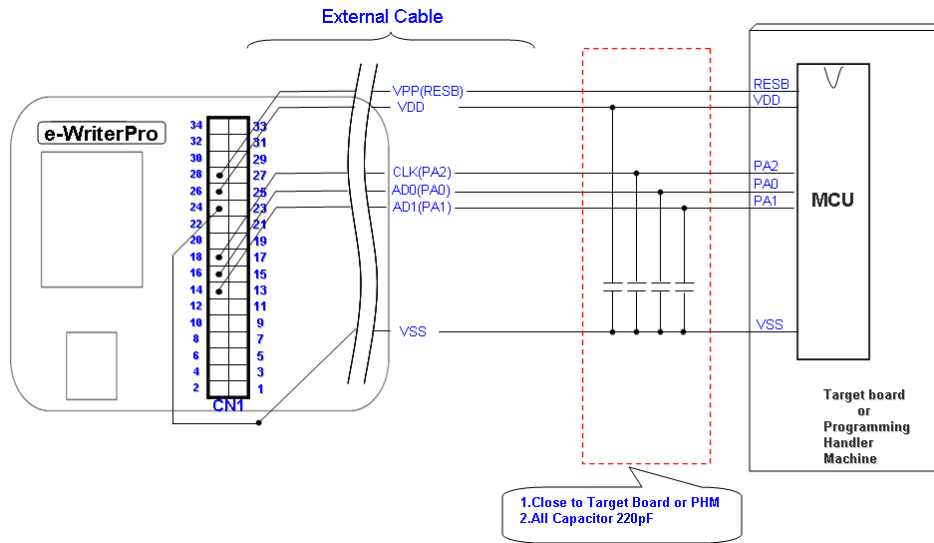

Fig. C-6

6) ICP-1F

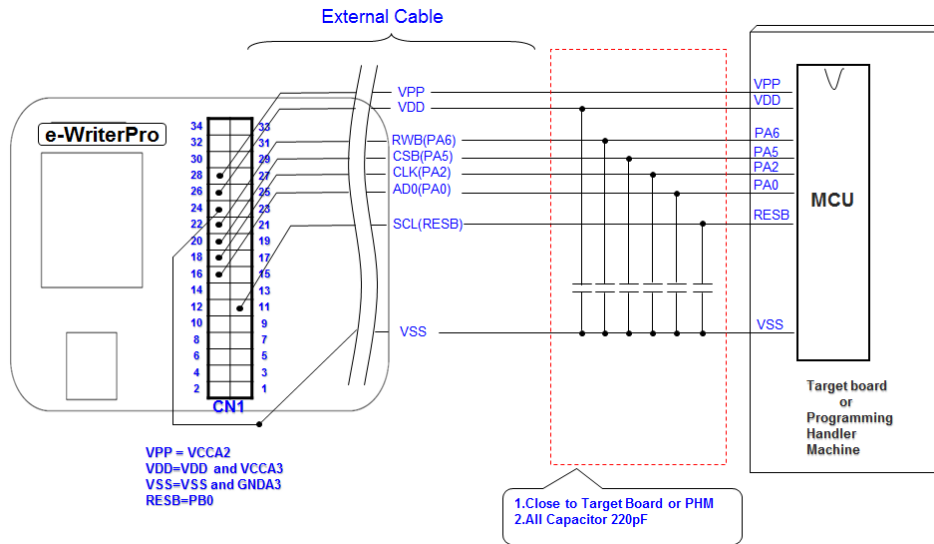

Fig. C-7

7) ICP-2A

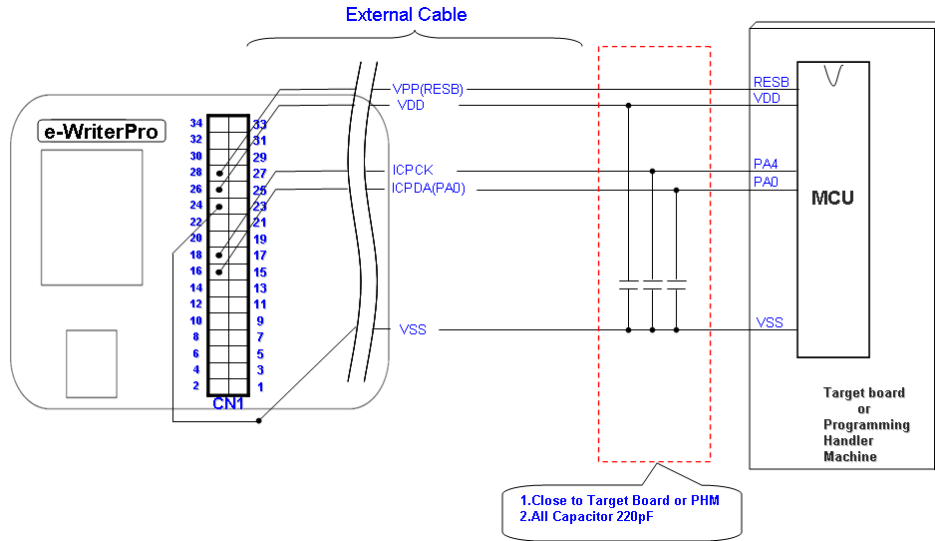

Fig. C-8

8) ICP-2B

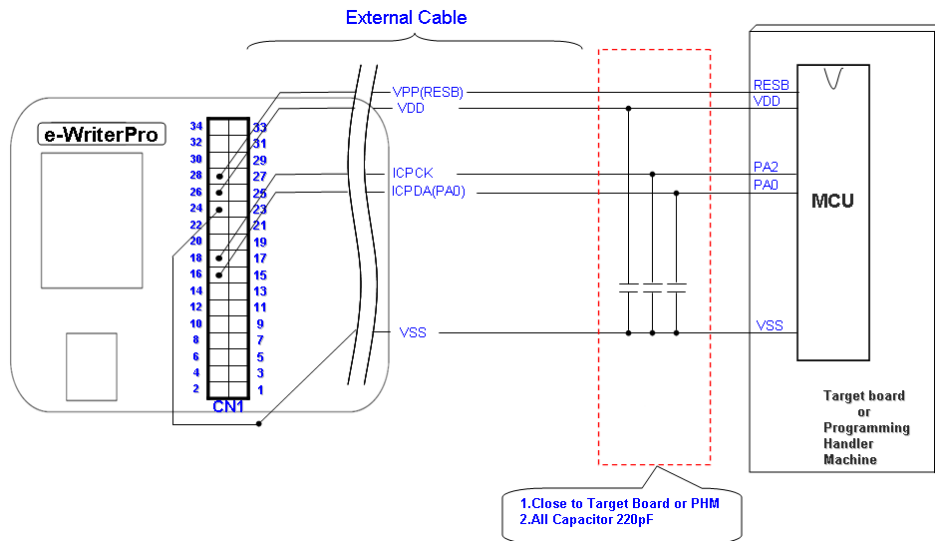

Fig. C-9

9) ICP-2C

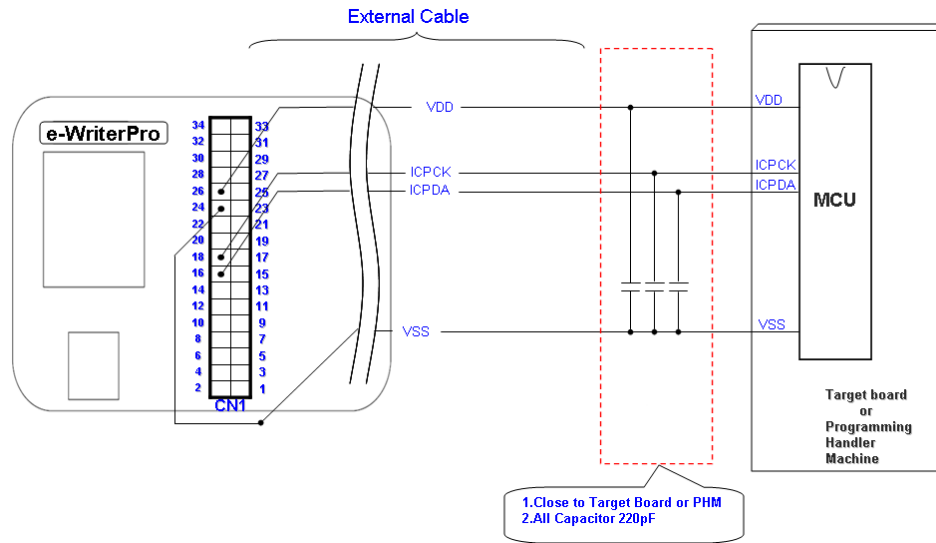

Fig. C-10

※ The actual pin location of the ICPDA and ICPCK pins in different MCUs may be different. Refer to the related chapter of the corresponding MCU datasheet.

ICP Considerations

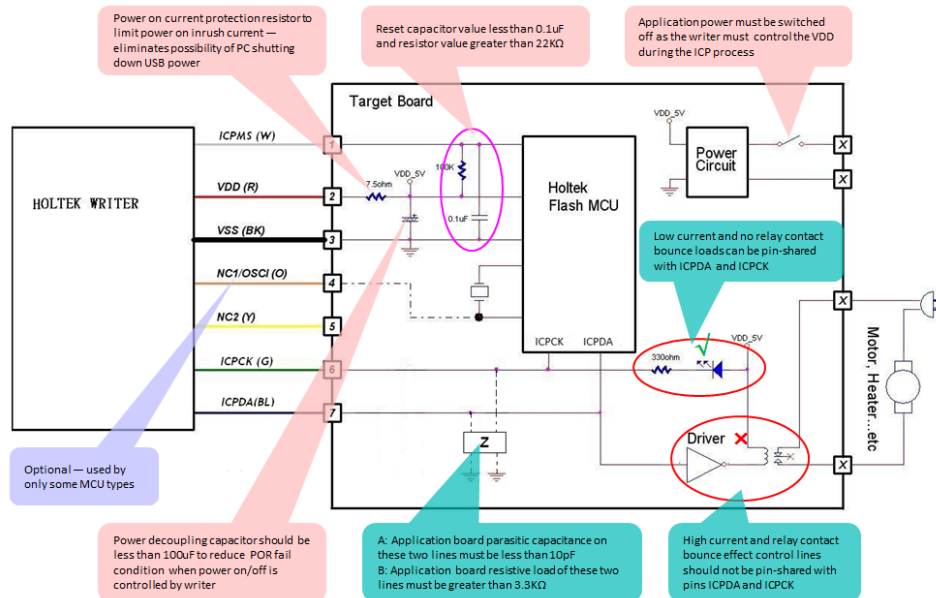

Fig. C-11

Note: If the e-WriterPro is used following the above procedures but still ineffective, it may be due to the excessively long lines or poor signal quality if the used ICP lines is not the ones included with the e-WriterPro. The following steps can be tried to resolve the problem:

1. Connect a 33~100Ω resistor in the line between the Target Board and the Holtek Writer ICPDA pin.
2. Connect a 33~100Ω resistor in the line between the Target Board and the Holtek Writer ICPCK pin.

Appendix D e-WriterPro CN3 Pin Definitions

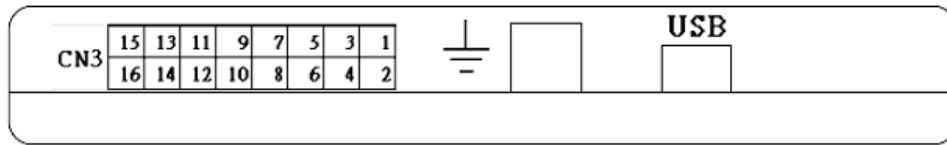

Fig. D-1

e-WriterPro CN3			
Pin	Name	Definition	Direction
1	EXPWI/USBPWO	External Power Input/USB Power Output	—
2	GND	Ground	—
3	EOP	End Of Program	e-WriterPro→
4	EXTG	External Trigger	e-WriterPro←
5	BIN2	IC is locked	e-WriterPro→
6	BIN1	Check ID/Blank Check/Program/Verify/Erase OK	e-WriterPro→
7	BIN7	Lock IC failed	e-WriterPro→
8	—	N/A	—
9	BIN4	IC is not blank	e-WriterPro→
10	BIN3	Check ID failed (for OTP MCUs)/Erase failed (for Flash MCUs)	e-WriterPro→
11	BIN6	Verify failed	e-WriterPro→
12	BIN5	Program failed	e-WriterPro→
13	—	N/A	—
14	SDA	I ² C SDA (Reserved)	e-WriterPro↔
15	—	N/A	—
16	SCL	I ² C SCL (Reserved)	e-WriterPro→

Table D-1

Copyright© 2019 by HOLTEK SEMICONDUCTOR INC.

The information appearing in this Data Sheet is believed to be accurate at the time of publication. However, Holtek assumes no responsibility arising from the use of the specifications described. The applications mentioned herein are used solely for the purpose of illustration and Holtek makes no warranty or representation that such applications will be suitable without further modification, nor recommends the use of its products for application that may present a risk to human life due to malfunction or otherwise. Holtek's products are not authorized for use as critical components in life support devices or systems. Holtek reserves the right to alter its products without prior notification. For the most up-to-date information, please visit our web site at <http://www.holtek.com>.