

High Speed Low Dropout Middle Current Voltage Regulators

■ General Description

The LN1134 series are highly precise, low noise, positive voltage LDO regulators manufactured using CMOS processes. The series achieves high ripple rejection and low dropout and consists of a standard voltage source, an error correction, current limiter and a phase compensation circuit plus a driver transistor. Output voltage is selectable in 100mV increments within a range of 1.5V ~ 5.0V. The series is also compatible with low ESR ceramic capacitors which give added output stability. This stability can be maintained even during load fluctuations due to the excellent transient response of the series.

The current limiter's feedback circuit also operates as a short protect for the output current limiter and the output pin. The CE function enables the output to be turned off, resulting in greatly reduced power consumption.

■ Features

- Output Voltage Range: 1.0V to 5.0V (selectable in 100mV steps)
- Highly Accurate: $\pm 2\%$
- Dropout Voltage: 300mV @ 100mA (3.0V type)

■ Ordering Information

LN1134 ①②③④⑤⑥

- High Ripple Rejection: 70dB (10 kHz)
- Low Power Consumption: 70 μ A (TYP.)
- Maximum Output Current : 300mA
- Standby Current : less than 2 μ A
- Internal protector: current limiter and short protector

■ Applications

- Mobile phones
- Cordless phones
- Cameras, Video cameras
- Portable games
- Portable AV equipment
- Reference voltage
- Battery powered equipment

■ Package

- SOT-23-5L
- DFNWB1.8 \times 2-6L
- SOT-353/SC70-5
- SOT-343

Designator	Symbol	Description	Designator	Symbol	Description
①		CE Pin Logic :	⑤		Package Type :
	A	Active 'High' (pull-down resistor built in)		M	SOT-23-5L
	B	Active 'High' (no pull-down resistor built in)		K	SOT-353/SC70-5
	C	Active 'Low' (pull-up resistor built in)		C	SOT-343
	D	Active 'Low' (no pull-up resistor built in)	D	DFNWB1.8 \times 2-6L	
②③	10-60	Output Voltage: e.g. 20 = 2.0V 30 = 3.0V etc.	⑥		Device Orientation :
④	2	Output Voltage : 100mV increments e.g. ②=3, ③=8, ④=2 \Rightarrow 3.8V		R	Embossed Tape : Standard Feed
	A	Output Voltage : 50mV increments e.g. ②=3, ③=8, ④=A \Rightarrow 3.85V		L	Embossed Tape : Reverse Feed

Pin Configuration

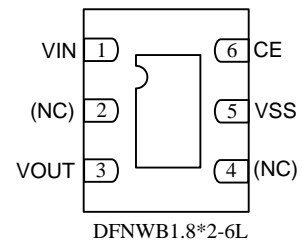
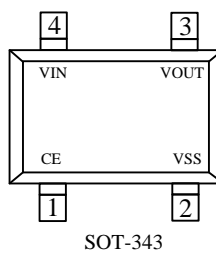
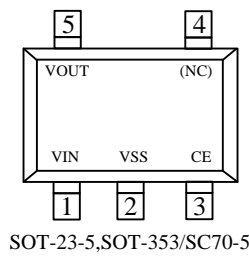

Pin Assignment

Pin Number				Pin Name	Function
SOT-23-5L	DFNWB1.8×2-6L	SOT-353/SC70-5	SOT-343		
1	1	1	4	VIN	Supply power
2	5	2	2	VSS	Ground
3	6	3	1	CE	Enable pin
4	2, 4	4	-	NC	NC
5	3	5	3	VOUT	Voltage output

Marking Rule

- SOT-23-5, SOT-353, SOT-343 (Top View)

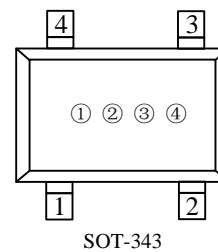
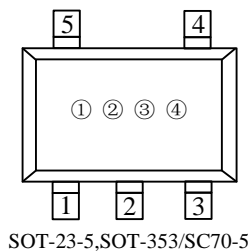

- ① Represents the product name

Symbol	Product Name
4	LN1134◆◆◆◆◆◆

- ② Represents the type of regulator

Voltage(V)	1.0~3.0	3.1~6.0	1.05~3.05	3.15~6.05		
Symbol	V	A	E	L	Product Name	LN1134A◆◆◆◆◆◆
	X	B	F	M		LN1134B◆◆◆◆◆◆
	Y	C	H	N		LN1134C◆◆◆◆◆◆
	Z	D	K	P		LN1134D◆◆◆◆◆◆

③ Represents the Output Voltage

Symbol	Output Voltage (V)			
0		3.1		3.15
1		3.2		3.25
2		3.3		3.35
3		3.4		3.45
4		3.5		3.55
5		3.6		3.65
6		3.7		3.75
7		3.8		3.85
8		3.9		3.95
9	1.0	4.0	1.05	4.05
A	1.1	4.1	1.15	4.15
B	1.2	4.2	1.25	4.25
C	1.3	4.3	1.35	4.35
D	1.4	4.4	1.45	4.45
E	1.5	4.5	1.55	4.55

Symbol	Output Voltage (V)			
F	1.6	4.6	1.65	4.65
H	1.7	4.7	1.75	4.75
K	1.8	4.8	1.85	4.85
L	1.9	4.9	1.95	4.95
M	2.0	5.0	2.05	5.05
N	2.1		2.15	
P	2.2		2.25	
R	2.3		2.35	
S	2.4		2.45	
T	2.5		2.55	
U	2.6		2.65	
V	2.7		2.75	
X	2.8		2.85	
Y	2.9		2.95	
Z	3.0		3.05	

④ Represents the assembly lot no.

0~9, A~Z repeated (G, I, J, O, Q, W excepted)

- DFNWB1.8×2-6L (Top View)

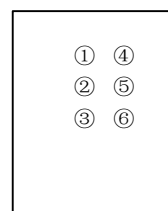

DFNWB1.8*2-6L

① ② Represents the product name

Symbol		Product Name
①	②	
3	4	LN1134xxxxDx

③ Represents the type of regulator

Symbol	Type	Product Name
A	Active 'High' (pull-down resistor built in)	LN1134AxxxDx
B	Active 'High' (no pull-down resistor built in)	LN1134BxxxDx
C	Active 'Low' (pull-up resistor built in)	LN1134CxxxDx
D	Active 'Low' (no pull-up resistor built in)	LN1134DxxxDx

④ Represents the integers of Output Voltage

Example: 3 represents 3.x, 5 represents 5.x

⑤ Represents the decimals of Output Voltage

Symbol	Voltage (V)	Product Name	Symbol	Voltage (V)	Product Name
0	X.0	LN1134XX0XDX	A	X.05	LN1134XXAXDX
1	X.1	LN1134XX1XDX	B	X.15	LN1134XXBXDX
2	X.2	LN1134XX2XDX	C	X.25	LN1134XXCXDX
3	X.3	LN1134XX3XDX	D	X.35	LN1134XXDXDX
4	X.4	LN1134XX4XDX	E	X.45	LN1134XXEXDX
5	X.5	LN1134XX5XDX	F	X.55	LN1134XXFXDX
6	X.6	LN1134XX6XDX	H	X.65	LN1134XXHXDX
7	X.7	LN1134XX7XDX	K	X.75	LN1134XXKXDX
8	X.8	LN1134XX8XDX	L	X.85	LN1134XXLXDX
9	X.9	LN1134XX9XDX	M	X.95	LN1134XXMXDX

⑥ Represents the assembly lot No.

0~9, A~Z repeated (G, I, J, O, Q, W excepted)

■ Function Block Diagram

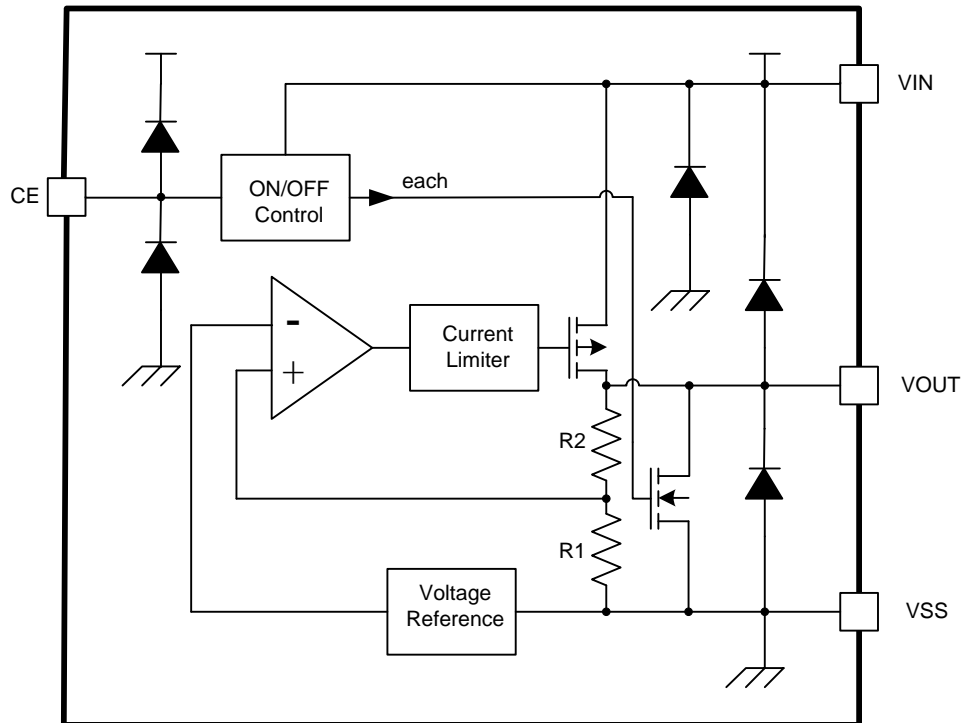

Absolute Maximum Ratings

Parameter	Symbol	Maximum Rating	Unit
Input Voltage	V_{IN}	$V_{SS}-0.3 \sim V_{SS}+8$	V
	$V_{ON/OFF}$	$V_{SS}-0.3 \sim V_{IN}+0.3$	
Output Current	V_{OUT}	$V_{SS}-0.3 \sim V_{IN}+0.3$	
Power Dissipation	P_D	SOT-23-5	400
		SOT-353/SC70-5, SOT-343	250
		DFNWB1.8×2-6L	100
Operating Ambient Temperature	T_{opr}	$-40 \sim +85$	°C
Storage Temperature	T_{stg}	$-40 \sim +125$	

Caution: The absolute maximum ratings are rated values exceeding which the product could suffer physical damage. These values must therefore not be exceeded under any conditions.

Typical Application Circuit

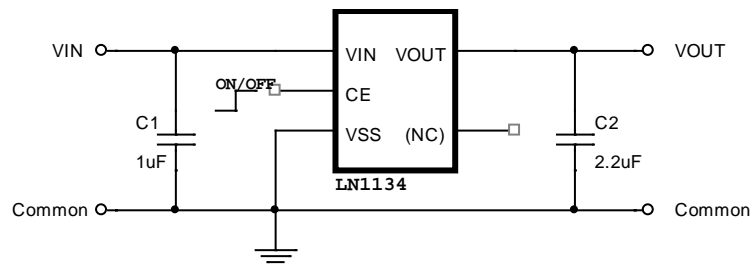

Caution: The above connection diagram and constant will not guarantee successful operation. Perform thorough evaluation using the actual application to set the constant.

Application Conditions

Input capacitor (C_{IN}): 1.0µF or more

Output capacitor (C_L): 1.0µF or more (tantalum capacitor)

Caution A general series regulator may oscillate, depending on the external components selected. Check that no oscillation occurs with the application using the above capacitor.

Test Circuits

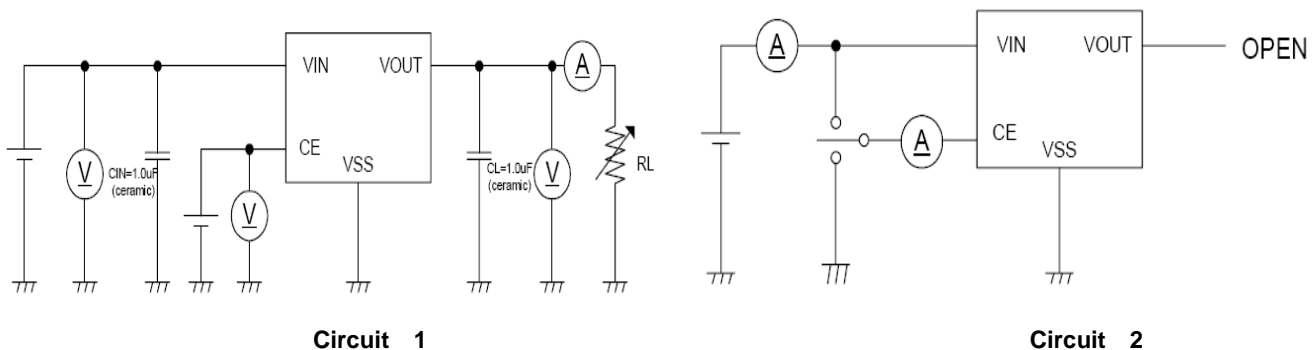

Electrical Characteristics

Parameter	Symbol	Condition	Min	Typ	Max	Unit	Circuit
Output Voltage	$V_{OUT(E)}$	$V_{IN} = V_{OUT(S)} + 1.0 \text{ V}$, $I_{OUT} = 30 \text{ mA}$	$V_{OUT(S)} \times 0.98$	$V_{OUT(S)}$	$V_{OUT(S)} \times 1.02$	V	1
Output Current	I_{OUT}	$V_{IN} \geq V_{OUT(S)} + 1.0 \text{ V}$	300	—	—	mA	1
Dropout Voltage	V_{drop}	$I_{OUT} = 50 \text{ mA}$	—	0.12	0.20	V	1
		$I_{OUT} = 100 \text{ mA}$	—	0.30	0.45		
Line Regulations	$\frac{\Delta V_{OUT1}}{\Delta V_{IN} \cdot V_{OUT}}$	$V_{OUT(S)} + 0.5 \text{ V} \leq V_{IN} \leq 8 \text{ V}$ $I_{OUT} = 30 \text{ mA}$	—	0.10	0.2	%/V	
Load Regulation	ΔV_{OUT2}	$V_{IN} = V_{OUT(S)} + 1.0 \text{ V}$ $1.0 \text{ mA} \leq I_{OUT} \leq 100 \text{ mA}$	—	50	100	mV	
Output Voltage Temperature Characteristics	$\frac{\Delta V_{OUT}}{\Delta T_a \cdot V_{OUT}}$	$V_{IN} = V_{OUT(S)} + 1.0 \text{ V}$, $I_{OUT} = 10 \text{ mA}$ $-40^\circ\text{C} \leq T_a \leq 85^\circ\text{C}$	—	± 100	—	ppm/ $^\circ\text{C}$	
Supply Current	I_{SS1}	$V_{IN} = V_{OUT(S)} + 1.0 \text{ V}$	—	70	—	μA	
Input Voltage	V_{IN}	—	2.0	—	8	V	—
Ripple-Rejection	PSRR	$V_{IN} = V_{OUT(S)} + 1.0 \text{ V}$, $f = 10 \text{ kHz}$ $V_{rip} = 0.5 \text{ V}_{rms}$, $I_{OUT} = 50 \text{ mA}$	—	70	—	dB	1
Short-circuit Current	I_{short}	$V_{IN} = V_{OUT(S)} + 1.0 \text{ V}$, V_{CE} on $V_{OUT} = \text{gnd}$	—	40	—	mA	1
CE "High" Voltage	V_{CEH}		1.6		V_{IN}	V	1
CE "Low" Voltage	V_{CEL}				0.25	V	1
CE "High" Current	I_{CEH}	$V_{IN} = V_{CE} = V_{OUT(T)} + 1.0 \text{ V}$	-0.1		0.1	μA	2
CE "Low" Current	I_{CEL}	$V_{IN} = V_{OUT(T)} + 1.0 \text{ V}$, $V_{CE} = V_{SS}$	-0.1		0.1	μA	2

■ Typical Performance Characteristics (3.0V output)

1、Output Voltage vs. Output Current

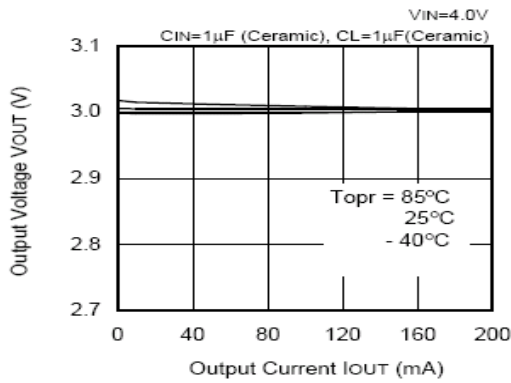

3、Dropout Voltage vs. Output Current

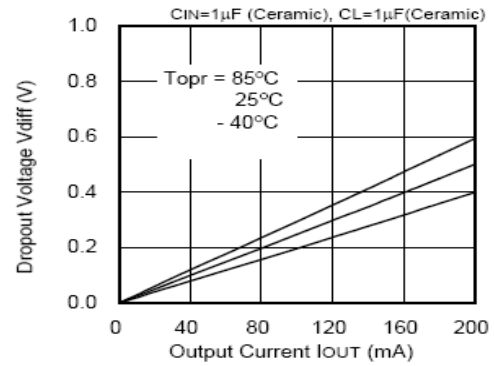

2、Output Voltage vs. Input Voltage (Contd.)

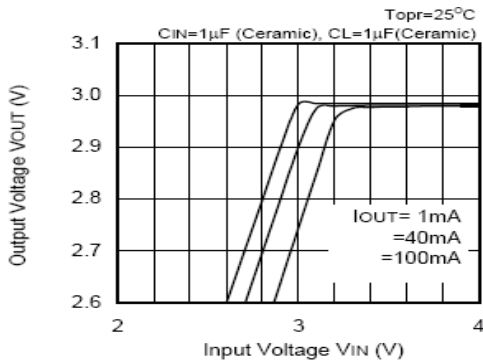

4、Dropout Voltage vs. Output Voltage

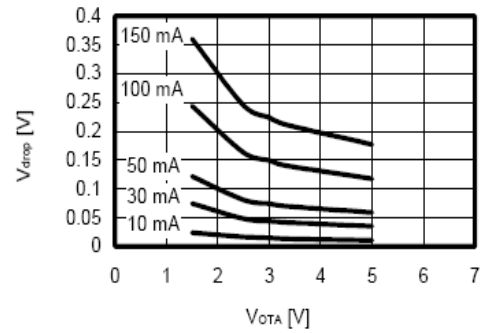

5、Output Voltage vs. Ambient Temperature

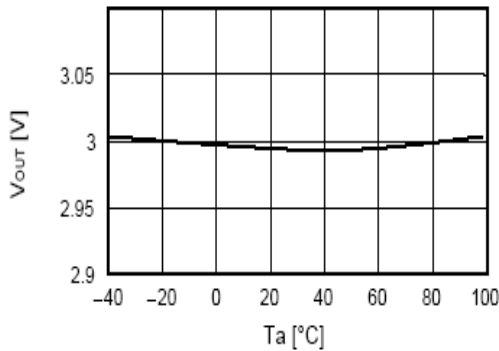

6、Ripple Rejection Rate

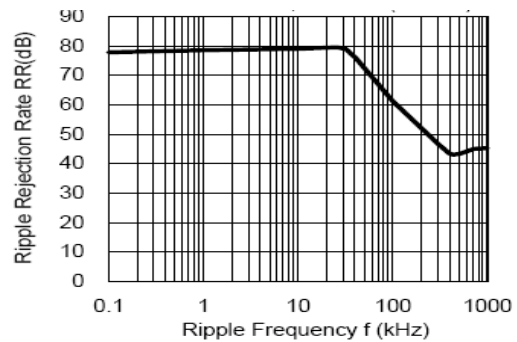

7、Transient Response

Input Transient Response

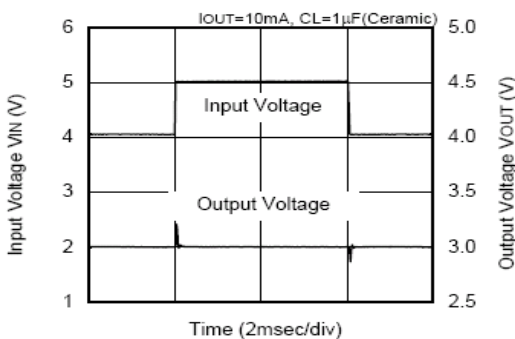

Load Transient Response

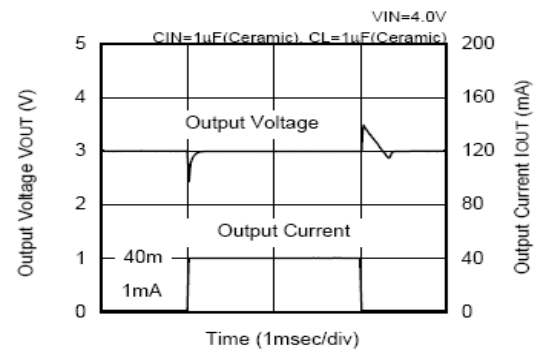

■ Package Information

- SOT-23-5L

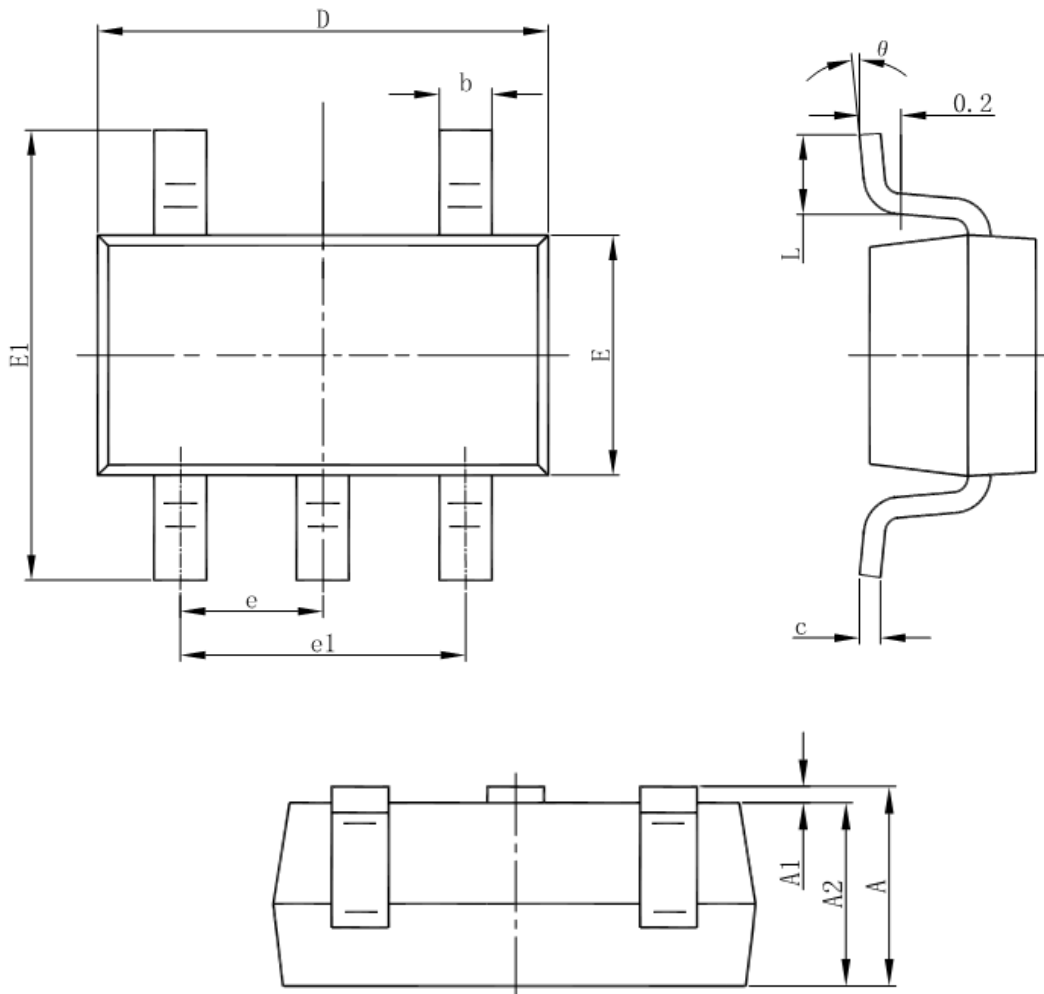

Symbol	Dimensions In Millimeters		Dimensions In Inches	
	Min	Max	Min	Max
A	1.050	1.250	0.041	0.049
A1	0.000	0.100	0.000	0.004
A2	1.050	1.150	0.041	0.045
b	0.300	0.500	0.012	0.020
c	0.100	0.200	0.004	0.008
D	2.820	3.020	0.111	0.119
E	1.500	1.700	0.059	0.067
E1	2.650	2.950	0.104	0.116
e	0.950(BSC)		0.037(BSC)	
e1	1.800	2.000	0.071	0.079
L	0.300	0.600	0.012	0.024
θ	0°	8°	0°	8°

● DFNWB1.8×2-6L

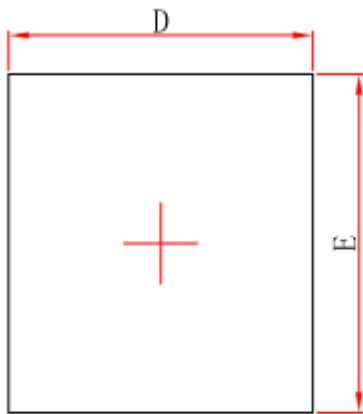

Top View

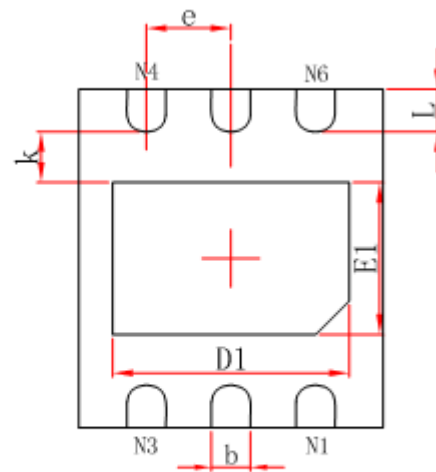

Bottom View

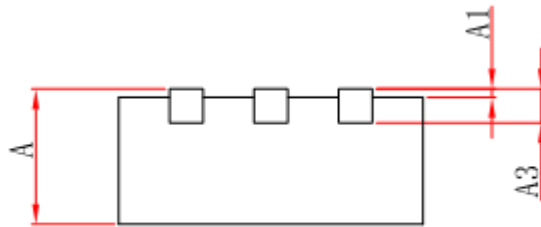

Side View

Symbol	Dimensions In Millimeters		Dimensions In Inches	
	Min.	Max.	Min.	Max.
A	0.450/0.550	0.550/0.650	0.018/0.022	0.022/0.026
A1	0.000	0.050	0.000	0.002
A3	0.150REF.		0.006REF.	
D	1.724	1.876	0.068	0.074
E	1.924	2.076	0.076	0.082
D1	1.300	1.500	0.051	0.059
E1	0.800	1.000	0.031	0.039
k	0.200MIN.		0.008MIN.	
b	0.180	0.280	0.007	0.011
e	0.500TYP.		0.020TYP.	
L	0.174	0.326	0.007	0.013

● SOT-353

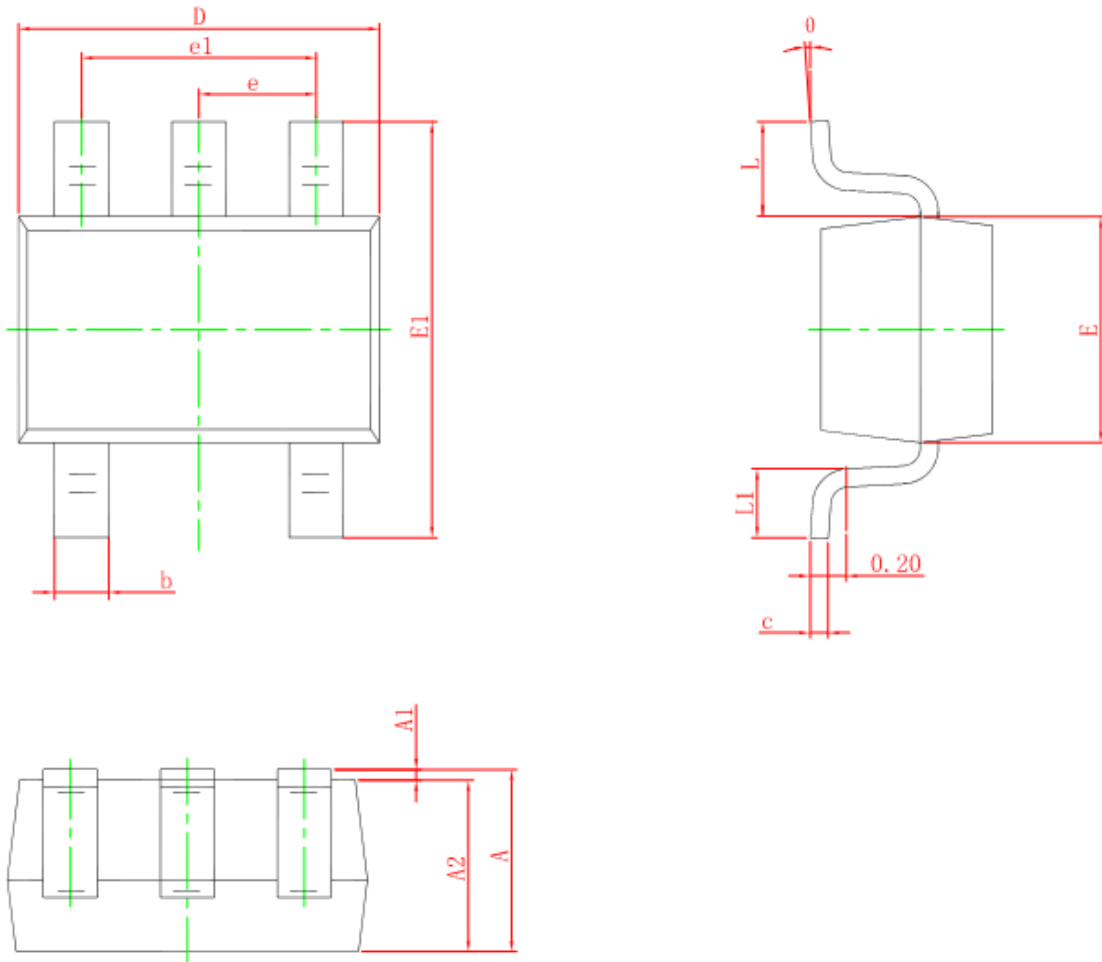

Symbol	Dimensions In Millimeters		Dimensions In Inches	
	Min	Max	Min	Max
A	0.900	1.100	0.035	0.043
A1	0.000	0.100	0.000	0.004
A2	0.900	1.000	0.035	0.039
b	0.150	0.350	0.006	0.014
c	0.080	0.150	0.003	0.006
D	2.000	2.200	0.079	0.087
E	1.150	1.350	0.045	0.053
E1	2.150	2.450	0.085	0.096
e	0.650 TYP		0.026 TYP	
e1	1.200	1.400	0.047	0.055
L	0.525 REF		0.021 REF	
L1	0.260	0.460	0.010	0.018
θ	0°	8°	0°	8°

● SOT-343

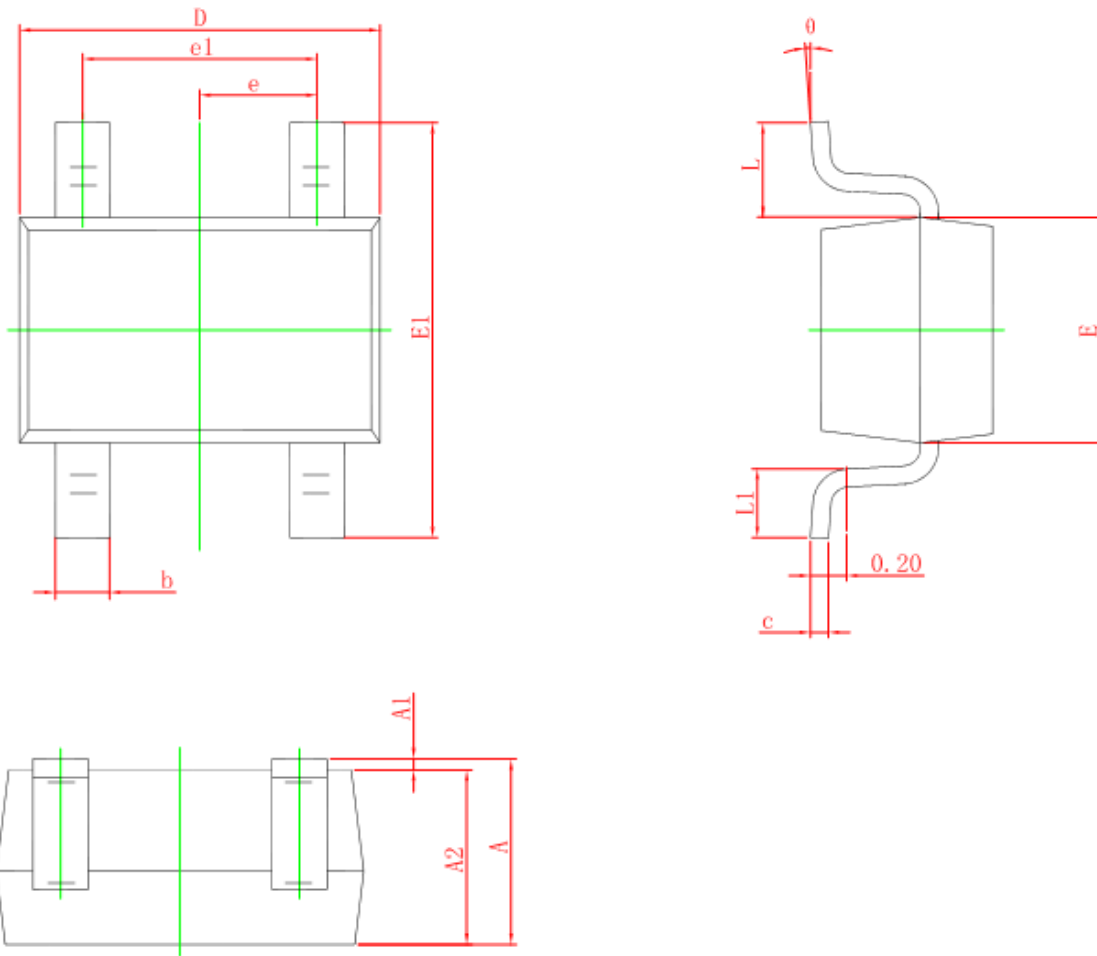

Symbol	Dimensions In Millimeters		Dimensions In Inches	
	Min	Max	Min	Max
A	0.900	1.100	0.035	0.043
A1	0.000	0.100	0.000	0.004
A2	0.900	1.000	0.035	0.039
b	0.150	0.350	0.006	0.014
c	0.080	0.150	0.003	0.006
D	2.000	2.200	0.079	0.087
E	1.150	1.350	0.045	0.053
E1	2.150	2.450	0.085	0.096
e	0.650 TYP		0.026 TYP	
e1	1.200	1.400	0.047	0.055
L	0.525 REF		0.021 REF	
L1	0.260	0.460	0.010	0.018
θ	0°	8°	0°	8°