



Carbon Monoxide Gas Sensor

(Model: ME2-CO- Φ 14x14)

Manual

Version: 1.6

Issue Date. 2023-03-20

Zhengzhou Winsen Electronics Technology Co., Ltd

Statement

This manual copyright belongs to Zhengzhou Winsen Electronics Technology Co., LTD. Without the written permission, any part of this manual shall not be copied, translated, stored in database or retrieval system, also can't spread through electronic, copying, record ways.

Thanks for purchasing our product. In order to let customers use it better and reduce the faults caused by misuse, please read the manual carefully and operate it correctly in accordance with the instructions. If users disobey the terms or remove, disassemble, change the components inside of the sensor, we shall not be responsible for the loss.

The specific such as color, appearance, sizes &etc, please in kind prevail.

We are devoting ourselves to products development and technical innovation, so we reserve the right to improve the products without notice. Please confirm it is the valid version before using this manual. At the same time, users' comments on optimized using way are welcome.

Please keep the manual properly, in order to get help if you have questions during the usage in the future.

Zhengzhou Winsen Electronics Technology CO., LTD

ME2-CO-Φ14x14 Carbon Monoxide Gas Sensor

Profile

ME2-CO-Φ14x14, fuel cell type sensor, detects gas concentration by measuring current based on the electrochemical principle, which utilizes the electrochemical oxidation process of target gas on the working electrode inside the electrolytic cell, the current produced in electrochemical reaction of the target gas are in direct proportion with its concentration while following Faraday law, then concentration of the gas could be get by measuring value of current.

Features

- * Low consumption
- * High precision
- * High sensitivity
- * Wide linear range
- * Good anti-interference ability
- * Excellent repeatability and stability



Main Applications

Widely used in commercial and especially residential field to detect CO concentration.

Technical Parameters

Item	Parameter
Detection gas	Carbon Monoxide (CO)
Measurement Range	0~1000ppm
Max detecting concentration	2000ppm
Sensitivity	>0.8nA/ppm
Resolution ratio	1ppm
Response time(T90)	<30S
Load resistance(recommended)	(500/1k/2k) Ω
Repeatability	<3% output value
Output Linearity	linear
Zero drift(-20°C~40°C)	≤10ppm
Temperature Range	-20°C~50°C
Humidity Range	15%~90%RH
Pressure range	Normal atmosphere±10%
Anticipated using life	3 years

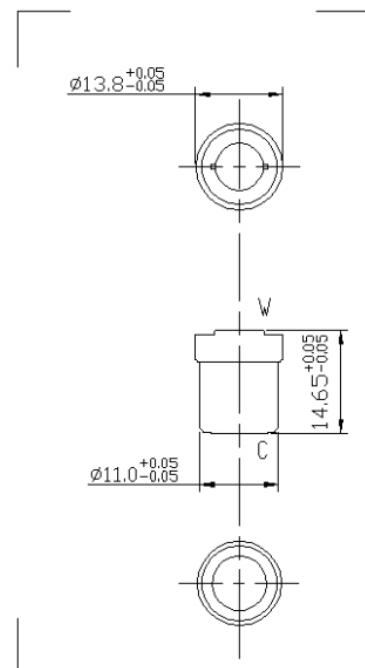

Fig1.Sensor structure

Basic Circuit

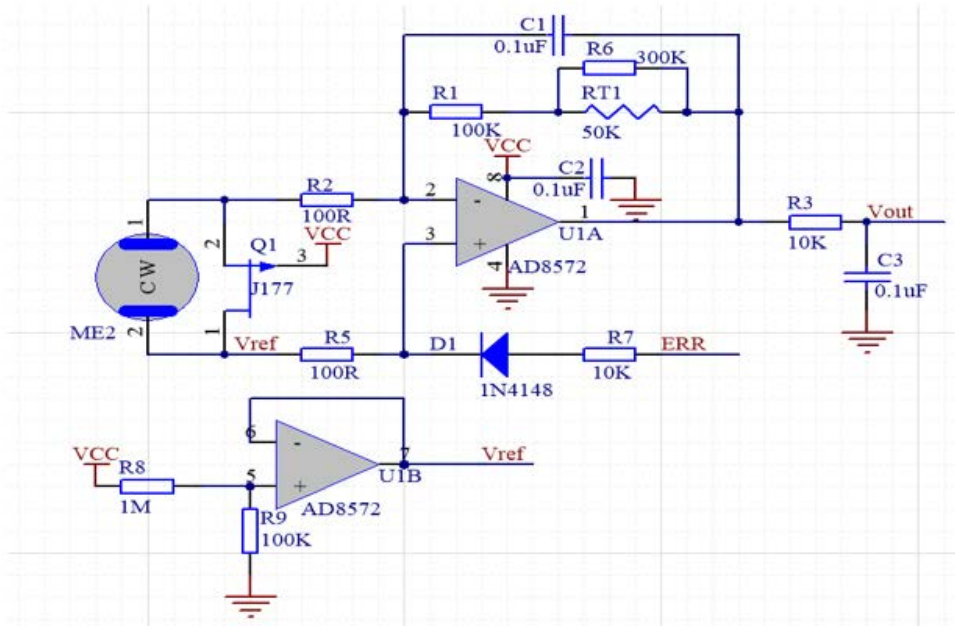

Fig2. Test circuit

Characterization

Fig3. Sensitivity response and recovery

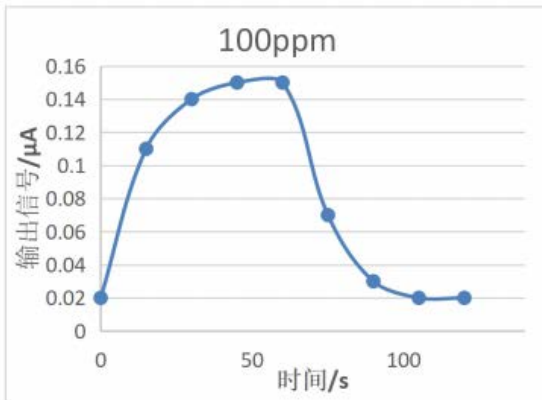

Fig4. Data graph of concentration linearity features

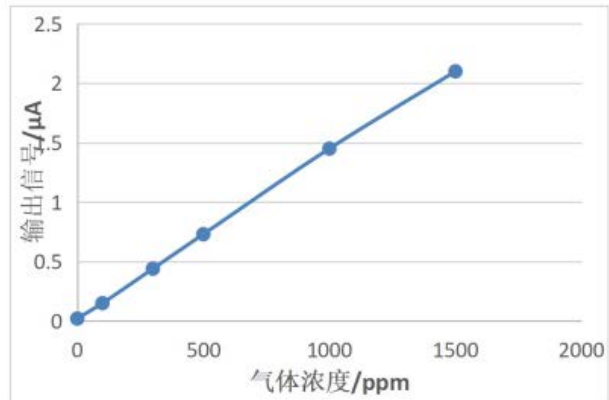

Fig5. Sensitivity upon variable temperature

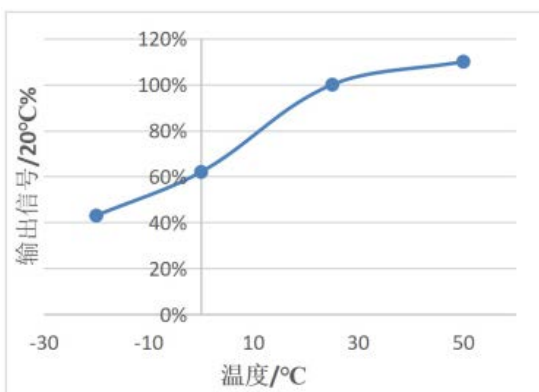
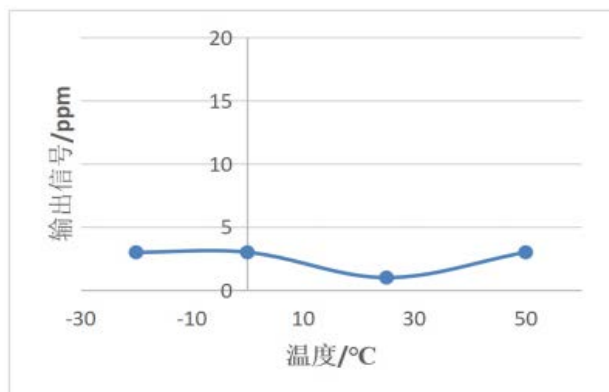

Fig6. Zero point upon variable temperature



Cross sensitivity:

ME2-CO-Φ14x14 sensor also responds to other gases besides CO. Below are the response characteristics of interferential gases for reference.

Gas	Concentration	ME2-CO-Φ14x14
H ₂ S	100ppm	0ppm
C ₂ H ₄	100ppm	80ppm
NO	35ppm	6ppm
NO ₂	5ppm	0ppm
C ₂ H ₅ OH	1000ppm	0ppm
CL ₂	10ppm	1ppm
SO ₂	20ppm	0.6ppm
H ₂	500ppm	43ppm
NH ₃	50ppm	1ppm
CH ₃ CL	5ppm	0ppm
ETO	10ppm	0ppm
C ₆ H ₆	100ppm	1.5ppm
C ₃ H ₆ O	100ppm	3.5ppm
CH ₃ OH	200ppm	0ppm

Application Notes:

- During installation, the lead can be welded, and the solder cannot contact the sensor.
- Before using, power on to aging for more than 48 hours is necessary.
- Don't disassemble the sensor.
- Avoid contacting organic solvent (including Silicone rubber and other adhesive), coatings, medicine, oil and high concentration gases.
- All the electrochemical sensors shall not be encapsulated completely by resin materials, and shall not immerse in non-oxygen environment, otherwise, it will damage the function of sensor.
- All electrochemical sensors shall not be applied in corrosive gas environment, or the sensor will be damaged.
- Zero calibration should be done in clean air.
- During test and usage, sensors should avoid the gas inflow vertically.
- The inlet hole can't be choked and polluted.
- The sensor shall not be subjected to excessive impact or vibration.
- Do not use the sensor if its shell is damaged or deformed.
- In high concentration gas environment, the recovery to the initial state is slow after a long time of use.
- When the sensor is stored, the working electrode and the counter electrode should be in short circuit.
- Do not use hot melt adhesive or sealant whose curing temperature is higher than 80 °C to encapsulate sensors.
- Do not store or use the sensor in high concentration alkaline gas for a long time.

Note: To keep continual product development, we reserve right to change design features without prior notice !

Zhengzhou Winsen Electronics Technology Co., Ltd

Add: No.299, Jinsuo Road, National Hi-Tech Zone.

Zhengzhou 450001 China

Tel: +86-371-67169097/67169670

Fax: +86-371-60932988

E-mail: sales@winsensor.com

Website: www.winsen-sensor.com

