

Web page analyser for protocols on ENC28J60 based AVR microcontroller

Mohammed Rahmatullah

M Tech, K L University, ECM Department,
Mohsin.md786@gmail.com

Abstract

Because the Internet is becoming more widespread, there was the possibility of communication with automation systems for configuration, reprogramming or control in real time. For this, the automation system needs a physical communication port with the network. This paper presents the design and implementation of such Ethernet interface for automation system with microcontroller, mainly analysing web page by making use of Protocols on AVR microcontroller and it focuses on the adoption of Agent Technology to analyse and evaluate the Web Content Traditional Web traffic analysis metrics such as page views, unique browser, visitor loyalty, etc have been used to analyse the Web traffic behaviour for a long time since the birth of World Wide Web, but the emersion of software robots and Web crawlers trigger a huge impact on the integrity and correctness of these traditional Web statistics. The connection between the automation system and the interface is made via an SPI (Serial Peripheral Interface) port. The main element of the interface is a chip named ENC28J60 manufactured by Microchip. It is designed to serve as an Ethernet network interface for any controller equipped with SPI. ENC28J60 meets all specifications of IEEE 802.3 having incorporated MAC and PHY modules. It also provides an internal mode DMA for fast data transfer and hardware for TCP/IP. With ENC28J60, an RJ45 connector and a few passive components we can connect a microcontroller to a 10 Mbps network. The access of ENC28J60 controller is done through configuration registers and memory. The interpretation of data to extract useful information is done by software routines. These interfaces have multiple applications: Remote monitoring of a system or industrial process, can be accessed on mobile devices with Internet connection, domestic applications.

1. Introduction

The paper aims to show how to make Ethernet interface with microcontroller automation systems. Are given at all stages of design, implementation and programming interface. The only requirement is that

the microcontroller to have SPI interface (Serial Peripheral Interface). SPI is a standard synchronous

high speed interface that operates in full duplex and can operate with one master device and one or more slave devices. A big disadvantage of this port is that transmission can only be a short distance till to 50-100 centimetres.

2. The Design of Interface

2.1. The network controller

The main element is the controller interface ENC28J60 made by Microchip company. It is designed to serve as an Ethernet network interface for any controller equipped with SPI. ENC28J60 meets all specifications of IEEE 802.3 having incorporated MAC and PHY modules. It also provides an internal mode DMA for fast data transfer and hardware for TCP/IP. The Enc28J60 has a clock at 25MHz.

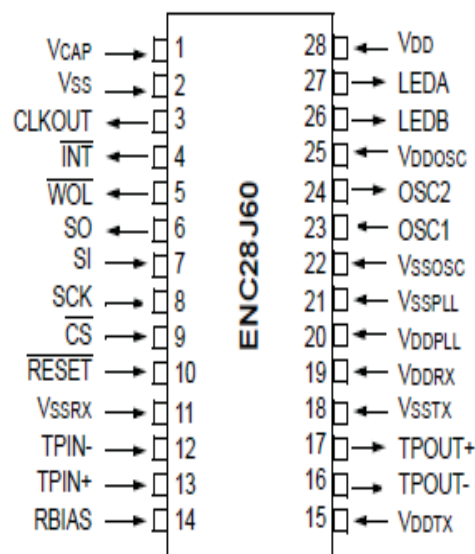

Figure 1: The ENC28J60

With Orcad 9.2 software package was designed electronic interface scheme, which is shown below. The PCB is shown in the figure achieved being conducted on two sides.

The LEDA and LEDB outputs of the controller can be used to view his activity. Their configuration is done

through a dedicated register. In this design these were connected to RJ45 network jack which will be described later. Next picture shows the footprints of components and the placement of these on pcb.

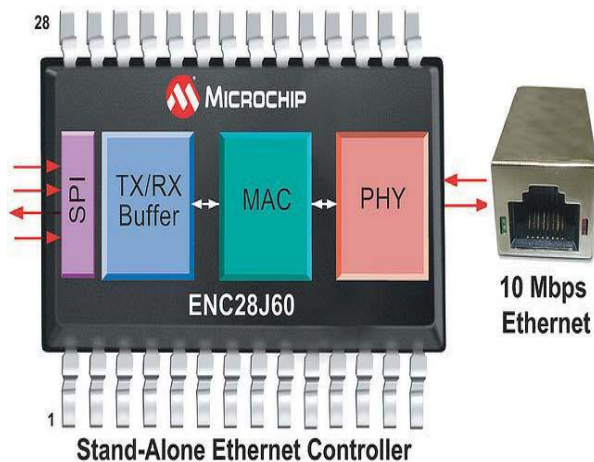

Figure 2: ENC28J60 block diagram

2.2. The Magjack connector

To connect the circuit to a computer network requires a circuit consisting of coils, diodes and resistors to ensure the electrical parameters of the line, controller protection and the possibility of using POE (Power-Over-Ethernet). For this, it has been identified the connector presented below. It has integrated magnetic system and can use Power over Ethernet technology, providing speeds of 10/100Mbps. Connector has built two green LEDs that can be used to display various information ENC28J60 controller (using the register PHLCON: PHY control register LED modules)

3. Ethernet Interface

In the Ethernet interface module, Ethernet controller are divided into two layers according to its functions and it is shown in Fig. 4. One is media access controller (MAC) layer and the other is network physical (PHY) layer. They correspond to Layer 2 and Layer 1 in ISO model. MAC layer provides the treatment on data sending and receiving. It also provides an interface to PHY through an internal medium independent interface

3.1 limitations of Ethernet

There are practical limits to the size of our Ethernet network. A primary concern is the length of the shared cable. Electrical signals propagate along a cable very quickly, but they weaken as they travel and electrical interference from neighbouring devices (fluorescent lights, for example) can scramble the signal. A network cable must be short enough that devices at opposite ends can receive each other's signals clearly and with minimal delay. This places a distance limitation on the maximum separation between two devices on an Ethernet network. Additionally, since in CSMA/CD only a single device can transmit at a given time, there are practical limits to the number of devices that can coexist in a single network. Ethernet networks face congestion problems as they increased in size. If a large number of stations connected to the same segment and each generated a sizable amount of traffic, many stations may attempt to transmit whenever there was an opportunity. Under these circumstances, collisions would become more frequent and could begin to choke out successful transmissions, which could take inordinately large amounts of time to complete. One way to reduce congestion would be to split a single segment into multiple segments, thus creating multiple collision domains. This solution creates a different problem, as now these now separate segments are not able to share information with each other.

To alleviate these problems, Ethernet networks implemented bridges. Bridges connect two or more network segments, increasing the network diameter as a repeater does, but bridges also help regulate traffic. They can send and receive transmissions just like any other node, but they do not function the same as a normal node. The bridge does not originate any traffic of its own; like a repeater, it only echoes what it hears from other stations. Ethernet is versatile enough to suit many purposes. Probably the best known use for Ethernet is in linking desktop computers in offices, but that's not its only use. Ethernet can transfer any kind of data, from short messages to huge files. An Ethernet communication can take advantage of existing higher-level protocols such as TCP and IP, or it can use an application-specific protocol. Ethernet doesn't require a large or fast computer. With the addition of an Ethernet

controller chip, even an 8-bit microcontroller can communicate in an Ethernet network.

4. The Automation System

Automation system was developed using a Atmel AVR microcontroller family: ATMEGA8. In fact, he was made a minimal automation system to allow testing.

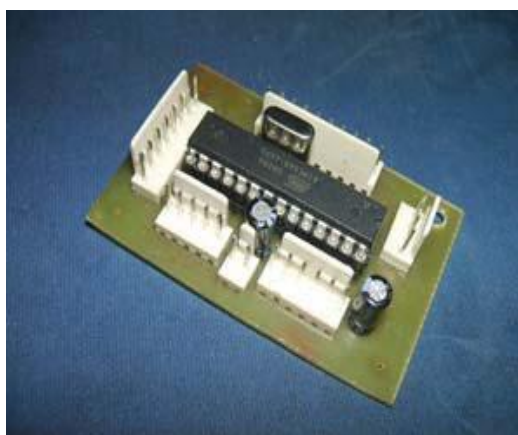

Figure 3: The automation system

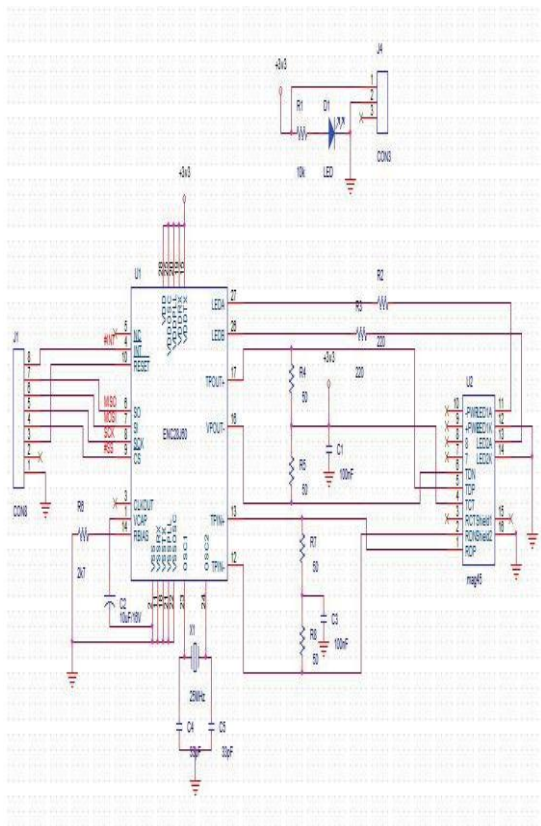

Figure 4: The electronic schematics

In the interconnection circuit is no conversion from 3.3V to 5V because the pins of ENC28J60 is a 5V voltage tolerant as the description from datasheet. After interconnection, the structure looks like following figure.

Atmega8	Ethernet interface
INT0	/INT
MISO	MISO
MOSI	MOSI
SCK	SCK
SS	/CS
+3.3V	/RESET
GND	GND

4.1 The Hardware Testing

To test the system hardware has made a dirt compound a computer connected to a network router. At the same router connected to the microcontroller system.

Note that the two have formed local network equipment in which each received a static IP address. ENC28J60 controller cannot be obtained automatically from the router IP address.

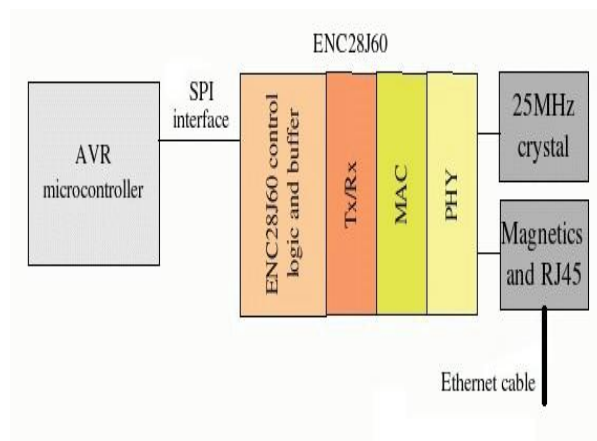

Figure 5. The system's structure

The ENC28J60 use involves setting a fixed IP address for it, a network mask and gateway address. That address is written in main procedure of software package as a unsigned integer on 8 bits array variable. Same way must be declared the net mask, gateway and DNS servers. Another important variable is the listen port: 80 for TCP and 1200 for UDP.

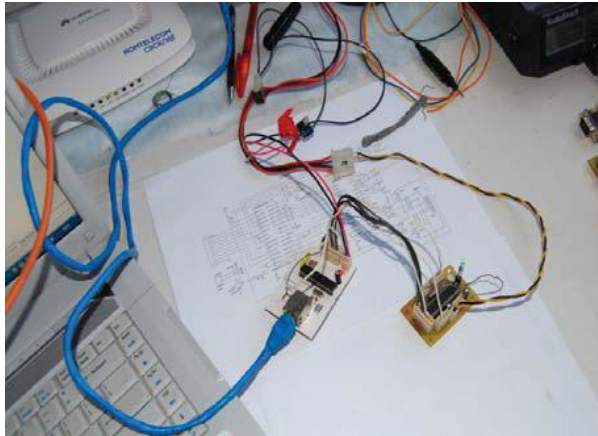

Figure 6.The Ethernet interface connected at microcontroller

5. The Software Package

The software package contains two components: One for the automation system Ethernet interface; one client to access the system. Several forms client application CAN take. Among These are: Application command prompt type; GUI Application for Windows; accessible HTML page in a browser; Application for Windows Mobile; Java Midlet for mobile phones; Application for smart phone with Android Operating system. Two versions were developed: an HTML page served by accessing microcontroller IP address even his own, and an application for smart phones with Android operating system. The router used to connect computer and microcontroller system is Huawei HG520s. Microcontroller has been allocated via the address 192.168.0.138. Below are some images rendered page served. The microcontroller software development was done in C and compiled with the programming environment called Atmel AVR Studio. The program is designed to consist of two main segments:

Ethernet communication to achieve; system management and implemented control algorithm realized by mcu. In the present study to further comment on the development of network communication routines. To achieve the objective programs designed and tested in the virtual environment provided by Proteus program. After

validation program has been adapted and tested microcontroller. Here are the steps algorithm to achieve the program microcontroller to configure ports; to configure the microcontroller SPI communication; to set the configuration registers of the circuit ENC28J60 (addresses, port); is expected to receive a network packet; Package type is detected; If the protocol is IP header is extracted it; if the type is TCP packet handler is calling the package. This routine transmits corresponding HTML page and running and switch pin 7 of port D.Our stack is a collection of different modules. Some modules (such as IP, TCP, UDP and ICMP) must be called when a corresponding packet is received. Any application utilizing our stack must perform certain steps to ensure that modules are called at the appropriate times. This task of managing stack modules remains the same, regardless of main application logic. To decode the package it was developed a stack task. Stack Task is implemented as a cooperative task; when given processing time, it polls the MAC layer for valid data packets. When one is received, it decodes it and routes it to the appropriate module for further processing. The steps used by stacktask are shown in the algorithm below.

6. Ethernet Controller Working:

This board utilizes the new Microchip ENC28J60 Stand-Alone Ethernet Controller IC featuring a host of features to handle most of the network protocol requirements. The board connects directly to most microcontrollers with a standard SPI interface with a transfer speed of up to 20MHz. This module contains what you need to enable Ethernet on your next microcontroller project. It includes a ENC28J60 ethernet controller, an RJ45 socket with link/activity lights and integrated transformer. This Ethernet module enables you to connect a particular embedded device (equipped with SPI support) on to a network. By using this Ethernet module (along with a microcontroller running a small TCP/IP stack) applications like Embedded Web server can be easily developed. Use this module to enable Ethernet interface for your product. It works with any microcontroller operating at 3.3V or 5V. This module works at 5V and is compatible with 5V interface lines. Use SPI process to interface with it. Host web server, ping the module or add it to home automation via internet. Heart of this module is ENC28J60 Ethernet controller from Microchip. This board is assembled with all components as shown in the picture. The circuit board includes all required components for the ethernet controller, plus a 3.3V Voltage Regulator and a RJ-45 jack with integrated transformer and built-in Link and

Activity LEDs for connection to an Ethernet Local Area Network.

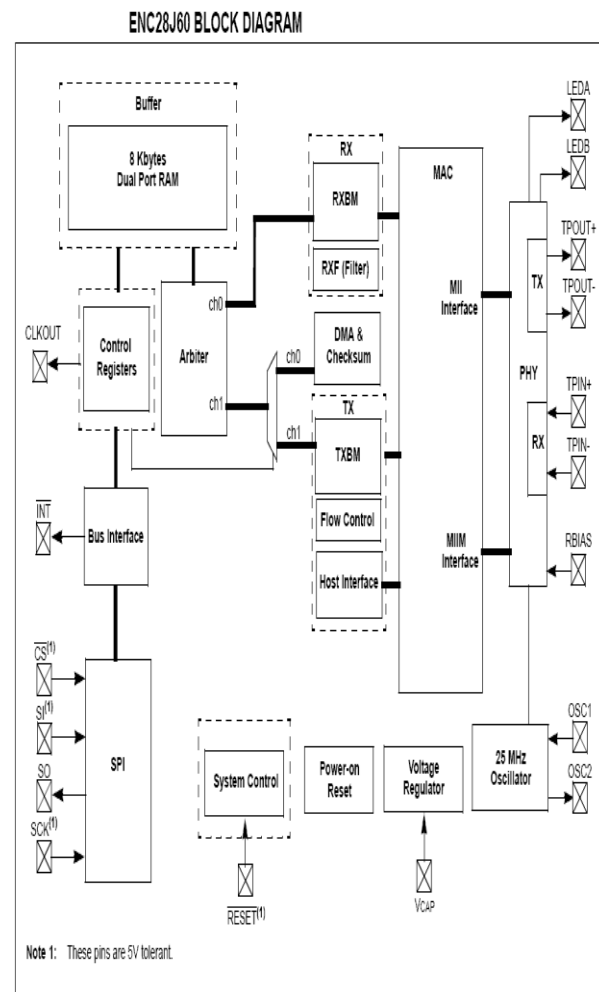

ENC28J60 BLOCK DIAGRAM

7. Applications

- Remote control and monitoring
- Data capture and logging
- Industrial Automation
- Building Automation
- Appliance remote management
- Robotics
- Microcontroller Research and Development
- TCP/IP Research and Development

8. Proposed Work

Search Engine Optimization has gained a lot of importance as it allows you to use your website to market your products and services on the Internet and

drive users and traffic to it. So search engine optimization (SEO) technique in order to find the rating of web and analysing may be tedious and time consuming ,so present physical modules came into existence and a new system has been proposed web page analysis based on the amount of time that web pages visited and the duration will be taken into consideration and gives the statistics.

9. Results and Output:

Here hardware requirements are AVR microcontroller LCD, display,power supply, ENC28j60,ADC,LM 35,Ethernet controller and software requirements are Code Vision AVR IDE tool Embedded C programming, STK 200/300 programmer.

9.1 Working Principle

In our project we will be using an electromechanical relay, which will be a 5 pin relay and the working of the relay will be like as. The general-purpose relay is rated by the amount of current its switch contacts can handle. Most versions of the general-purpose relay have one to eight poles and can be single or double throw. These are found in computers, copy machines, and other consumer electronic equipment and appliances.

DC Motor Relay

RELAYS: A relay is usually an electromechanical device that is actuated by an electrical current. The current flowing in one circuit causes the opening or closing of another circuit. Relays are like remote control switches and are used in many applications because of their relative simplicity, long life, and proven high reliability. Relays are used in a wide variety of applications throughout industry, such as in telephone exchanges, digital computers and automation systems. Highly sophisticated relays are utilized to protect electric power systems against trouble and power blackouts as well as to regulate and control the generation and distribution of power. In the home, relays are used in refrigerators, washing machines and dishwashers, and heating and air-conditioning controls. Although relays are generally associated with electrical circuitry, there are many other types, such as pneumatic and hydraulic. Input may be electrical and output directly mechanical, or vice versa.

All relays contain a sensing unit, the electric coil, which is powered by AC or DC current. When the applied current or voltage exceeds a threshold value, the coil activates the armature, which operates either to

close the open contacts or to open the closed contacts. When a power is supplied to the coil, it generates a magnetic force that actuates the switch mechanism. The magnetic force is, in effect, relaying the action from one circuit to another. The first circuit is called the control circuit; the second is called the load circuit.

On/Off Control: Example: Air conditioning control, used to limit and control a “high power” load, such as a compressor Limit Control:

Example: Motor Speed Control, used to disconnect a motor if it runs slower or faster than the desired speed

10. AVR Studio Software

10.1 ISP Flash Microcontroller Programmer:

Complete In-System Programming Solution for ARM Microcontrollers
Covers All ARM Microcontrollers with In-System Programming Support
Reprogram Both Data Flash and Parameter EEPROM Memories
Complete Schematics for Low-cost In-System Programmer
Simple Three-wire SPI Programming Interface

Working of ISP programmer:

In-System Programming allows programming and reprogramming of any ARM microcontroller Positioned inside the end system. Using a simple three-wire SPI interface, the In-System Programmer communicates serially with the ARM microcontroller, reprogramming all non-volatile memories on the chip. In-System Programming eliminates the physical removal of chips from the system. This will save time, and money, both during development in the lab, and when updating the software or parameters in the field. This application note shows how to design the system to support In-System Programming. It also shows how a low-cost In-System Programmer can be made, that will allow the target ARM microcontroller to be programmed from any PC equipped with a regular 9-pin serial port. Alternatively, the entire In-System Programmer can be built into the system allowing it to reprogram itself.

11.STEPS FOR CREATING A CODE VISION AVR INTEGRATED DEVELOPMENT ENVIRONMENT:

If we just use compiler and linker independently we still need to get a text editor. So combining everything will actually mess things up. So the best way is to get Software which has it all. That’s called an Integrated Development Environment, in short IDE.

I consider Code-Vision-AVR to be the best IDE for getting started with AVR programming on Windows XP, Vista. It has a very good Code Wizard which generate codes automatically you need not mess with the assembly words. So in all my tutorials I will be using CV AVR. You can download evaluation version for free which has code size limitation but good enough for our purpose. For all my examples I will be using Atmega-32 as default microcontroller because it very easily available and is powerful enough with sufficient number of pins and peripherals we use. You can have a look on the datasheet of Atmega-32 in the datasheet section. Let’s take a look on the software. The main window looks like following,

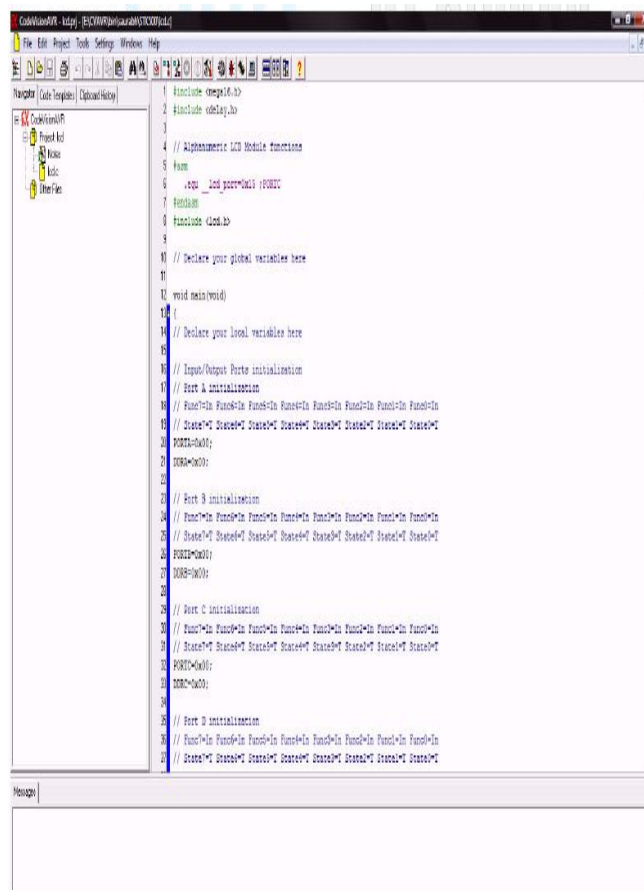

Figure 8.CVAVR

PORT is usually a collection of 8 pins. From this tab you can select which pin you want to configure as output and which as input. It basically writes the DDR and PORT register through this setting. Registers are basically RAM locations which configure various peripherals of microcontroller and by changing value of these registers we can change the function it is performing. I will talk more about registers later. So you can configure any pin as output or input by clicking the box. You can also set initial value of the Pins you want to assign or if you are using a pin as input then whether you want to make it as pull-up or tri stated, again I will talk in details about these functions later. Similarly using this code wizard you can very easily configure all the peripherals on the AT mega. Now for generating code just go to File ----> Generate, Save and Exit (of the code wizard) now it will ask you name and location for saving three files. Two being project files and one being the .C file which is your program. try to keep same names of all three files to avoid confusion. By default these files are generated in C:\CVAVR\bin the generated program will open in the text editor. Have a look it has some declarations like PORT, DDR, TCCR0 and many more. These are all registers which configures various functions of AT mega and by changing these value we make different functions. All the details about the registers are commented just below them. Now go down and find following infinite while loop there. We can start writing our part of program just before the while loop. And as for most of the applications we want microcontroller to perform the same task forever we put our part of code in the infinite while loop provided by the code wizard.

Now we want to generate the hex file, so first compile the program. Either press F9 or go to Project ---> Compile. It will show compilation errors if any. If program is error free we can proceed to making of hex file. So either press Shift+F9 or go to Project ----> Make. A pop up window will come with information about code size and flash usage etc. So the machine file is ready now it is in the same folder where we saved those 3 files.



Figure 9. The result of output window

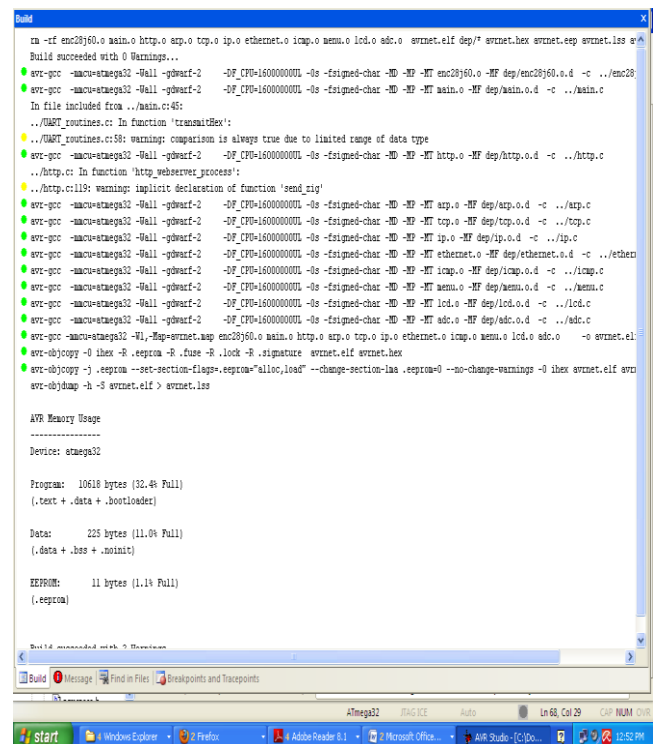

Figure10. Snapshot of the window after compilation

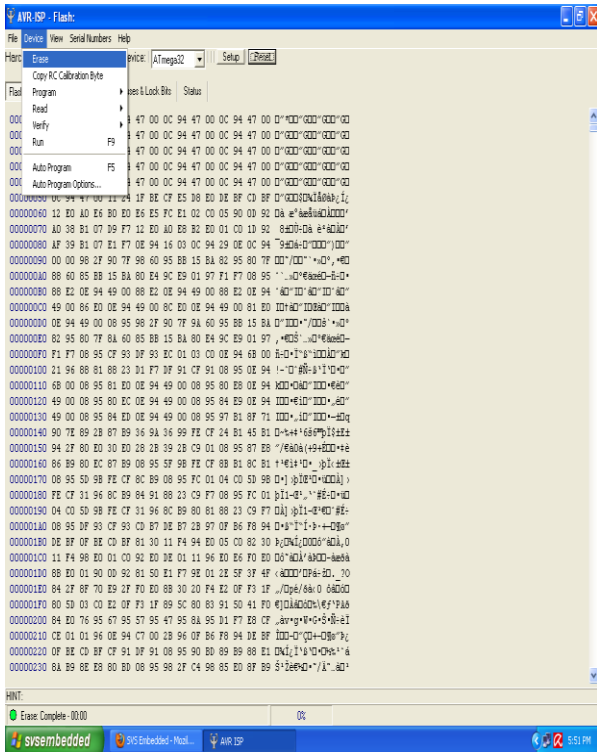

Figure 11(a) Generating hex files, AVR ISP1

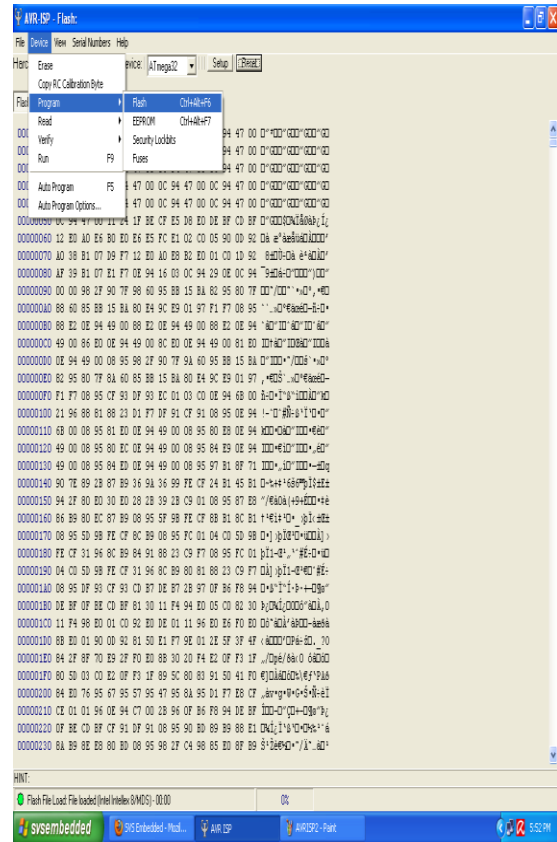
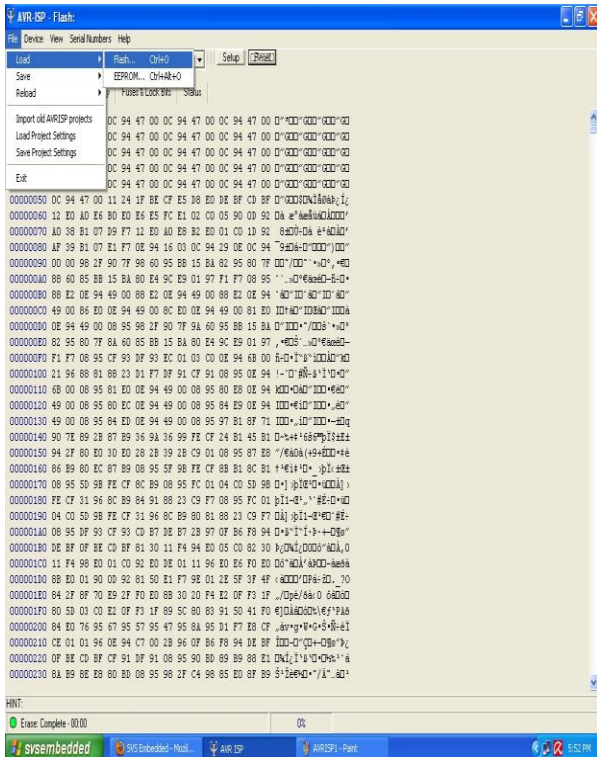

Figure 11(c) AVR ISP 3



11(b) AVR ISP Flash programming 2

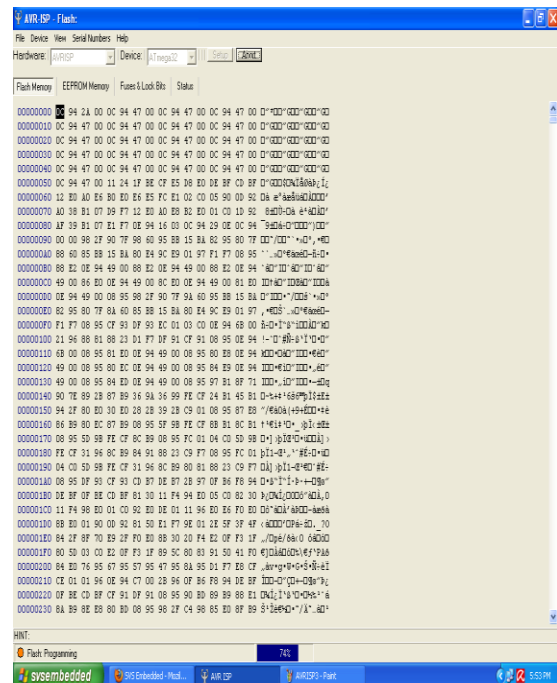

Figure 11(d) AVR ISP 4

9. Conclusion:

Search engine optimization (SEO) was replaced by web content engagement time in order to find out the rating of different e –publications and e-adds which focuses on the page duration particularly the amount of time users visits the web page. Web Channel platform, promising Web Content Engagement Time (WCET) are recorded, which provides not only integrity and confidence for the publishers and advertisers, but also shines a new light for the future agent-based target marketing and e-reader profile and reading behaviour analysis, for statistical readings its impossible for advertisers to promote in e-publications due to web traffic so it be can be tackle with this proposed system with better results.

10. References

- [1]Jeremy Bentham -TCP/IP lean-Web servers for Embedded Systems.
- [2]H. Veenstra and J.R. Long, “Circuit and interconnect design for rf and high bit-rate applications” 2008.
- [3]SunnyP. Gomasa, Fakhrul Alam - Wireless sensor networks over internet protocol and web services - International Journal of Intelligent Systems Technologies and Applications. Volume 9, Number 2.
- [4]Jeremy Bentham -TCP/IP lean-Web servers for Embedded Systems.
- [5]H. Veenstra and J.R. Long, —Circuit and interconnect design for rf and high bit-rate applicationsl 2008.
- [6] Dhananjay, V.G.: Programming and Customizing the AVR Microcontroller, McGraw-Hill, 2001.
- [7] Jan, Axelson: Embedded ETHERNET and Internet complete. Lakeview Research LLC, 2003.
- [8] Wu, Li Wei, and Hu., Jwu Sheng, —Distribut ed Embedded Ethernet Platform for Robots Control.l IEEE International Conference on Mechatronics, Taiwan, 2005.
- [9] YU Cheng-bo, LIU Jie, and TAO Hong-yan, “Reseach on remote monitor technology of equipment,” Information and Control, Magn. China, vol.31(3), pp.236-240, June 2002.
- [10] LIU Hong-li, “The Research and Experiment of the Embedded System μ C /OS-II on PC,” Journal of Shanghai University of Electric Powe, Magn. China, vol.5(7), pp.275-248, June 2009.
- [11] ZHANG Shi, DONG Jianwei, SHE Lihuang, “Design and development of ECG monitor’s software system,” Compute.