



Quectel Wireless Solutions

Wireless Module Expert



L70 GPS Module Presentation

July, 2012

□ General description

- Highlights
- Mechanical Dimension
- Hardware Architecture
- Firmware
- Target Applications

□ Features

- Receiver Performance
- Specifications
- Self-AGPS EASY™ technology
- Periodic Standby Mode
- AlwaysLocate™ technology
- L70 vs. Ucompany NEX-6Q

□ Support Package

MT3339 Single Chip Solution

66 acquisition channels
22 tracking channels

Ultra Low Power Consumption

22mA @ Tracking mode
25mA @ Acquisition mode

AlwaysLocate™

An intelligent controller of power consumption

LOCUS

Innate logger solution without host and external flash



Extremely Compact Size

10.1 x 9.7 x 2.5 mm

EASY™

Advanced AGPS technology without external memory

Anti-Jamming

Multi-tone Active Interference Canceller

Highest Sensitivity

-163dBm @ Tracking mode
-148dBm @ Cold Start

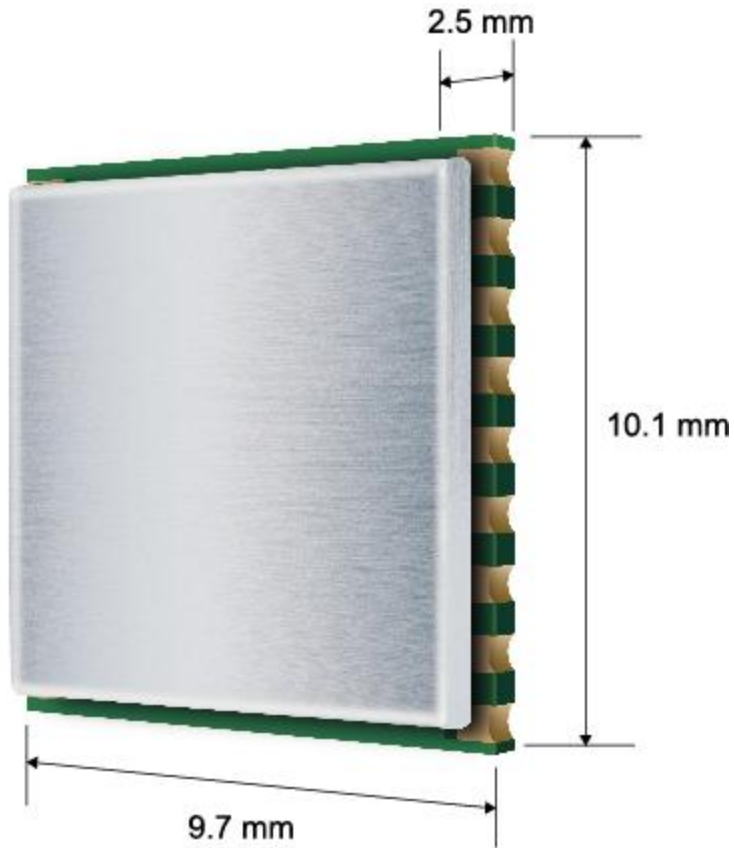

Length: 10.1 mm
Width: 9.7 mm
Height: 2.5 mm
Weight: 0.6 g

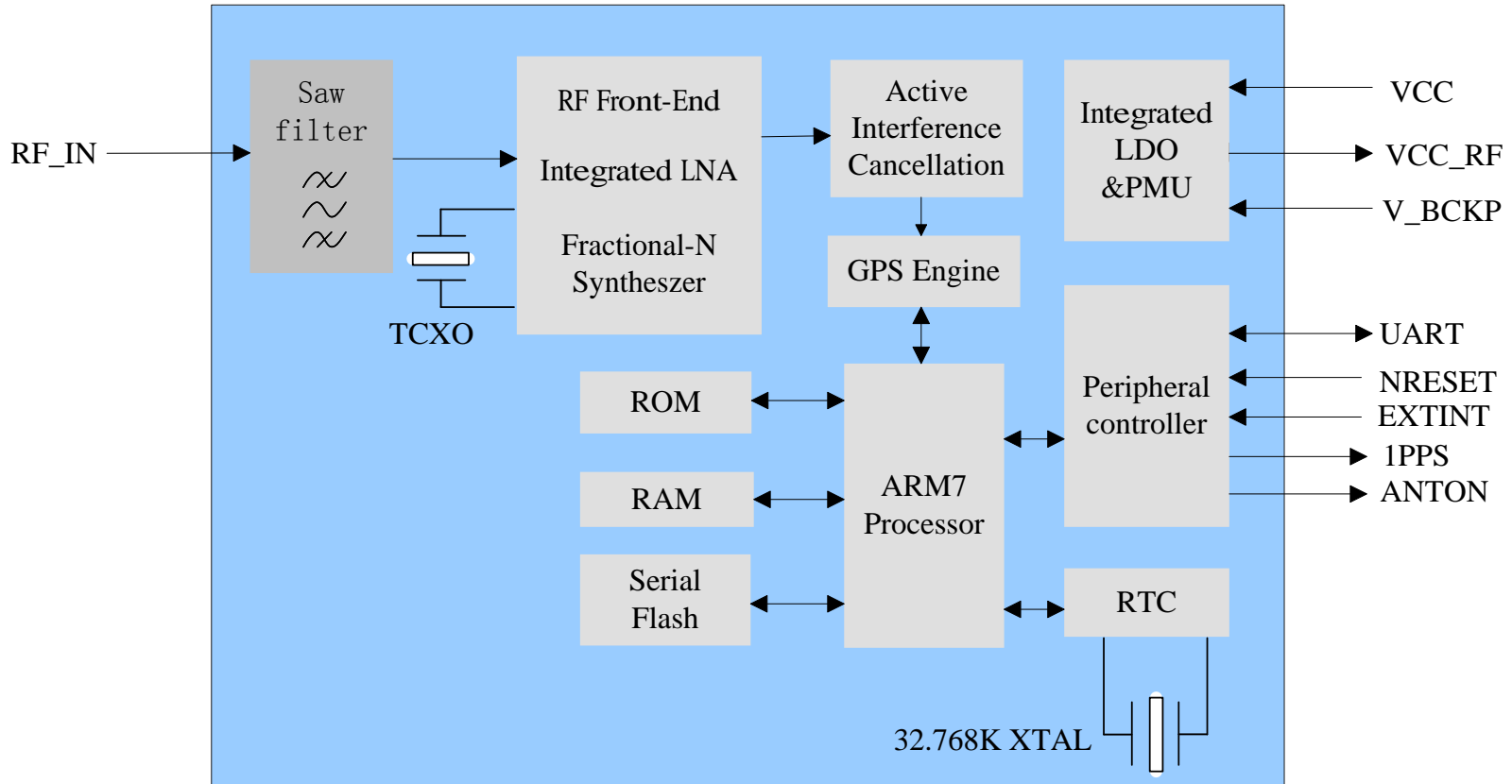

- Protocol
 - NMEA 0183 standard V3.01
 - MTK Private Protocol: PMTK
- Configurable Operating Modes
 - UART: Adjustable 4800~115200bps(default: 9600bps)
 - Update rate: 1Hz (default), up to 10Hz
 - Selectable output NMEA messages
 - Configurable periodic Standby Mode

- Portable Devices
- Vehicle Management
- Asset Tracking
- Security System
- Connected PND
- GIS Application
- Industrial PDA



□ General description

- Highlights
- Hardware Architecture
- Software Technology
- Mechanical Dimension
- Target Applications

□ Features

- Receiver Performance
- Specifications
- Self-AGPS EASY™ technology
- Periodic Standby Mode
- AlwaysLocate™ technology
- L70 vs. Ucompany NEX-6Q

□ Support Package

- EASY™, advanced AGPS technology without external memory
- Extremely low power consumption, 22mA@tracking, 25mA@acquisition
- AlwaysLocate™, an intelligent controller of periodic mode
- LOCUS, innate logger solution without Host and external flash
- Highly sensitivity, -163dBm@Tracking, -148dBm@Cold Start
- 66 acquisition channels, 22 tracking channels
- Support DGPS, RTCM, QZSS, SBAS(WASS/EGNOS/MSAS/GAGAN)
- Anti-Jamming, Multi-tone Active Interference Canceller

L1 Band Receiver (1575.42MHz)	Channel	22 (tracking) / 66 (acquisition)
	C/A code	
	SBAS	WAAS, EGNOS MSAS, GAGAN
Horizontal Position Accuracy	Autonomous	<2.5 m CEP
Velocity Accuracy	Without aid	<0.01m/s
Acceleration Accuracy	Without aid	0.1 m/s ²
Timing Accuracy	1PPS out	10ns
Reacquisition Time		<1 s
TTFF@-130dBm with EASY™	Cold Start	<15s
	Warm Start	<5s
	Hot start	<1s
TTFF@-130dBm without EASY™	Cold Start	<35s
	Warm Start	<30s
	Hot Start	<1s
Sensitivity	Cold Start	-148dBm
	Tracking	-163dBm
	Re-acquisition	-160dBm

Note1: Measured in the conductive mode under a GPS signal generator.

Note2: AlwaysLocate™ is an intelligent controller of periodic mode.

Note3: An external LNA is recommended when using passive antenna

Environmental	Operating Temperature	-40°C to 85°C
	Storage Temperature	-45°C to 125°C
Dynamic Performance	Maximum Altitude	Max.18000m
	Maximum Velocity	Max.515m/s
	Maximum Acceleration	4 G
Dimensions	10.1 x 9.7 x 2.5 mm	
Weight	Approx. 0.6 g	
Serial Interface	UART: Adjustable 4800~115200 bps Default: 9600bps	
Update Rate	1Hz by default, up to10Hz	
I/O Voltage	2.7V ~ 2.9V	
Protocols	NMEA 0183 PMTK	
Power Supply	2.8V ~ 4.3V	
Power Acquisition	25mA @ -130dBm (Note1)	
Power Tracking	22mA @ -130dBm (Note1)	
Power Saving	3mA@AlwaysLocate™ (Note2)	
	7uA@Backup Mode	
	500uA@Standby Mode	
	Periodic mode	
Antenna Type	Active or Passive (Note3)	
Antenna Power	External or Internal VCC_RF	

- EASY™ is the abbreviation for Embedded Assist System for quick positioning. With EASY™ technology, the GPS engine can calculate and predict automatically single ephemeris (up to 3 days) when the power is on, and then save the predict information onto the memory. So the GPS engine can use the information for positioning later if there are not enough information received from the satellites.
- This function will be helpful for positioning and TTFF improvement under indoor or urban conditions.

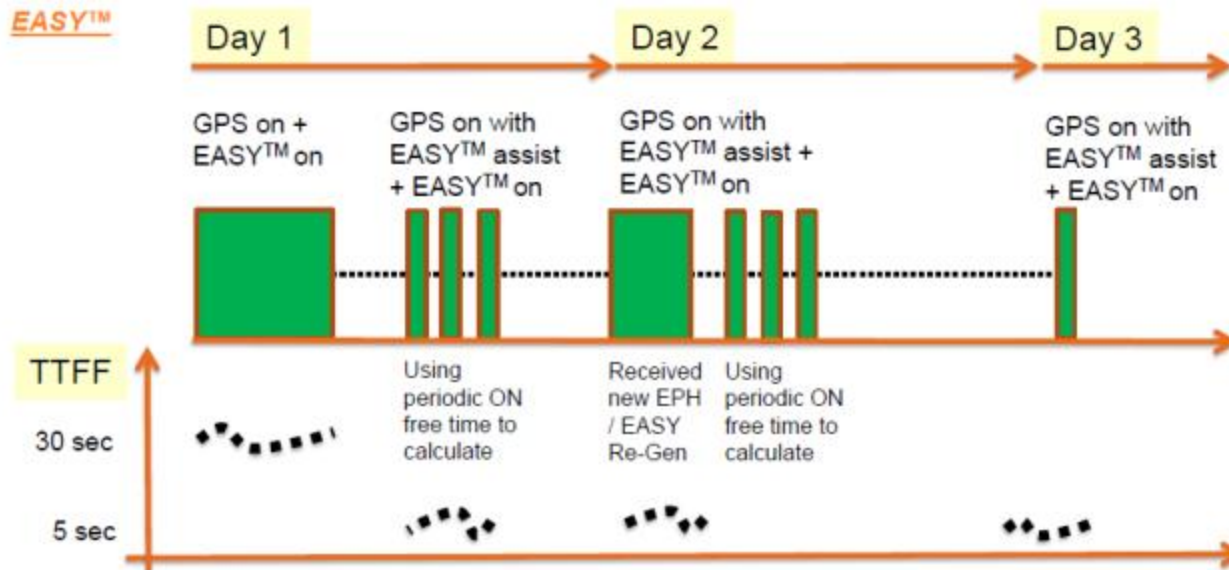

➤ TTFB Comparison

Test Condition		TTFB without EASY	TTFB with EASY
Under GPS signal Generator, conductive power level -130dBm	Cold Start	<35s	<15s
	Warm Start	<30s	<5 s

With EASY™ technology, L70 accelerates TTFB obviously.

- Controlling power on/off Standby Mode periodically can reduce power consumption.
- On/Off time can be configured by using PMTK command.
- For example, On for 3 seconds, Off for 12 seconds

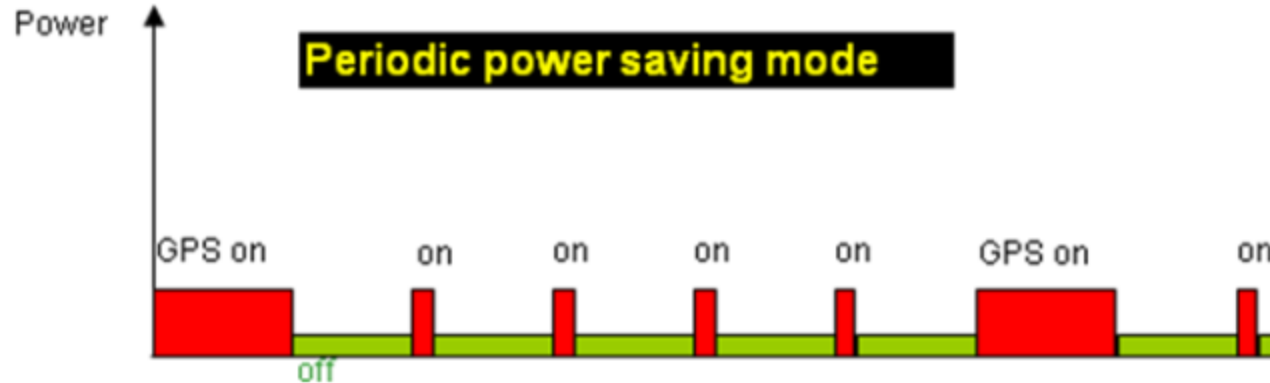

- AlwaysLocate™ is an intelligent controller of periodic mode.
- L70 can adaptively adjust the on/off time to achieve balance between positioning accuracy and power consumption according to the environmental and motion conditions.

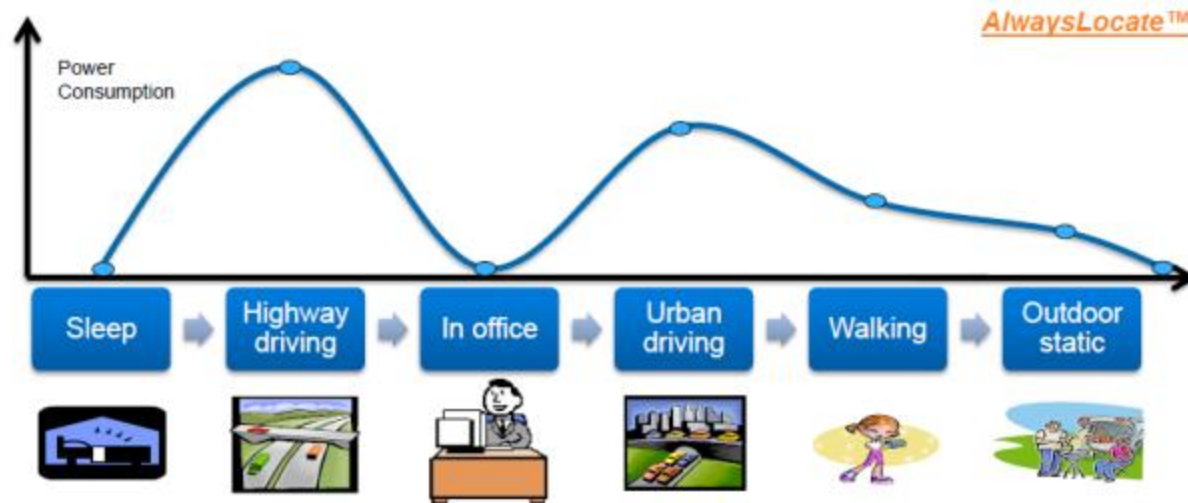

➤ Specifications Comparison

Product Features		L70	Ucompany NEX-6Q
Power supply		2.8V~4.3V	2.7V~3.6V
Power consumption	Acquisition mode	25mA @ 3.3V	117mW @ 3.0V Typical
	Tracking mode	22mA @ 3.3V	
Sensitivity	Cold start	-148dBm	-148dBm
	Hot start	-160dBm	-157dBm
	Tracking	-163dBm	-162dBm
	Re-acquisition	-160dBm	-160dBm
TTFF @ -130dBm	Hot start	<1s	1s
	Warm start	<5s (EASY™)	26s
	Cold start	<15s (EASY™)	26s
Position accuracy		2.5m CEP	2.5m CEP
Timing accuracy	1PPS	10ns	30ns
Data update rate		Up to 10Hz	Up to 5Hz

➤ Tracking Comparison

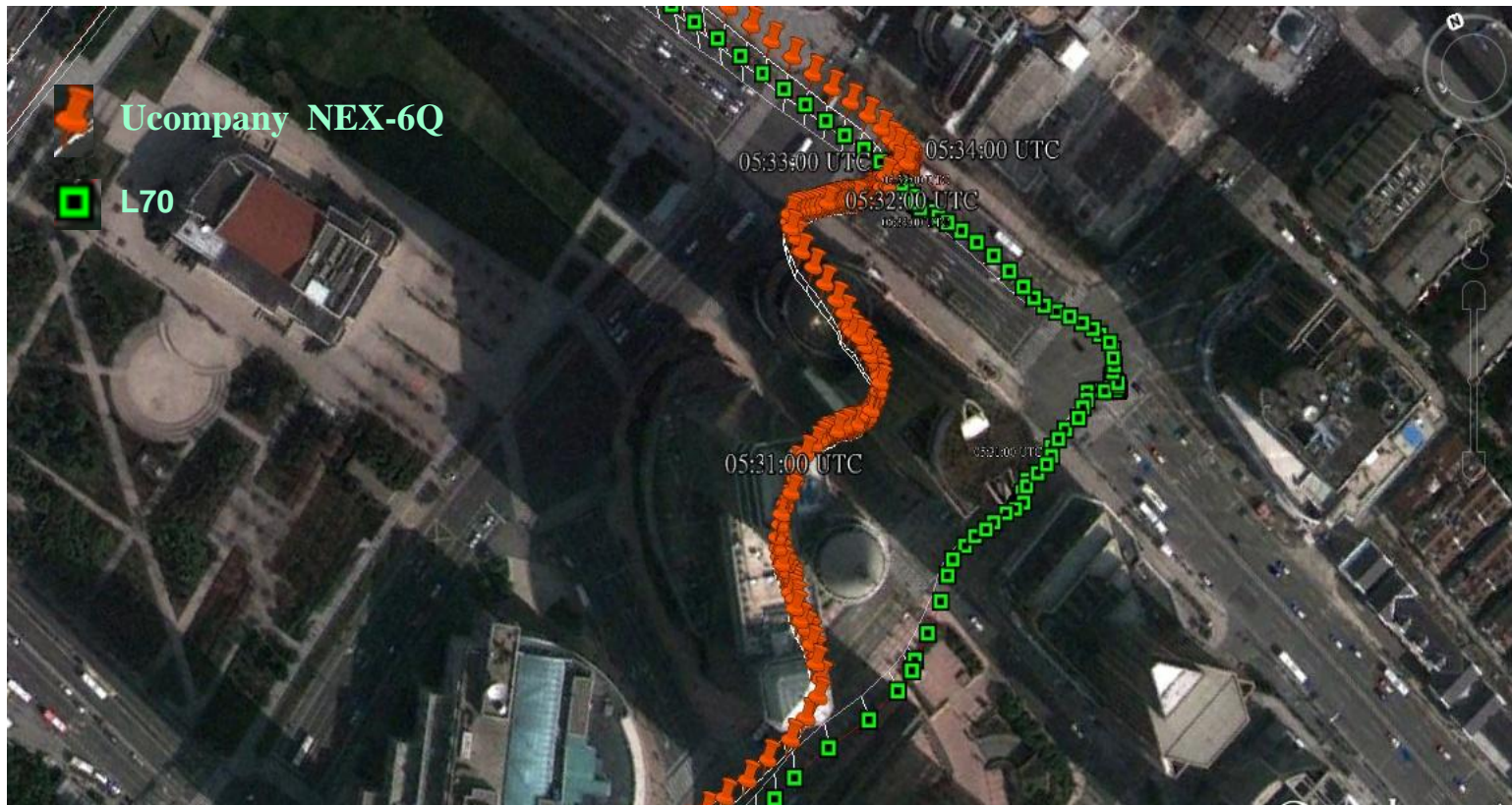

When driving across high buildings and making a turn, L70 module can still capture the accurate tracking data.

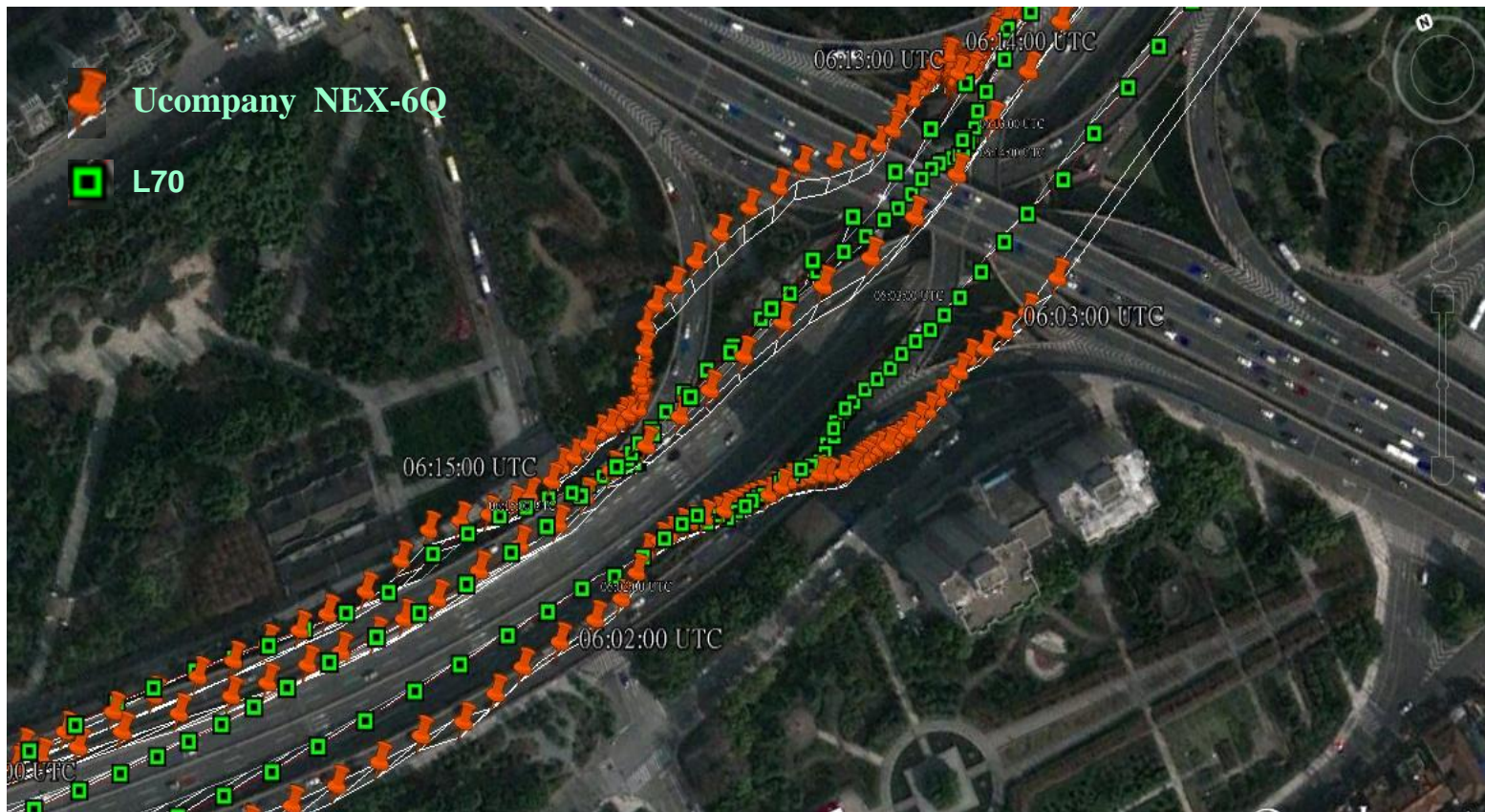
➤ Tracking Comparison

When driving back and forth under the overpass, L70 module has small drift.

➤ Tracking Comparison

When driving into a channel, the GPS signal becomes weak. L70 can still fix position for a while.

□ General description

- Highlights
- Hardware Architecture
- Software Technology
- Mechanical Dimension
- Target Applications

□ Features

- Receiver Performance
- Specifications
- Self-AGPS EASY™ technology
- Periodic Standby Mode
- AlwaysLocate™ technology
- L70 vs. Ucompany NEX-6Q

□ Support Package

Evaluation Board

➤ Interfaces

- GPS serial port
- Antenna interface
- Adapter interface

➤ Accessories

- Serial port cable
- DC 5V/2A power adapter
- GPS antenna



➤ Documents

- <<Hardware Design>>
- <<GPS protocol>>
- <<Part&Decal in PADS and Protel format>>
- <<Evaluation Board User Guide>>
- <<Circuit Reference Design>>

➤ PC tool

- MiniGPS-GPS testing tool

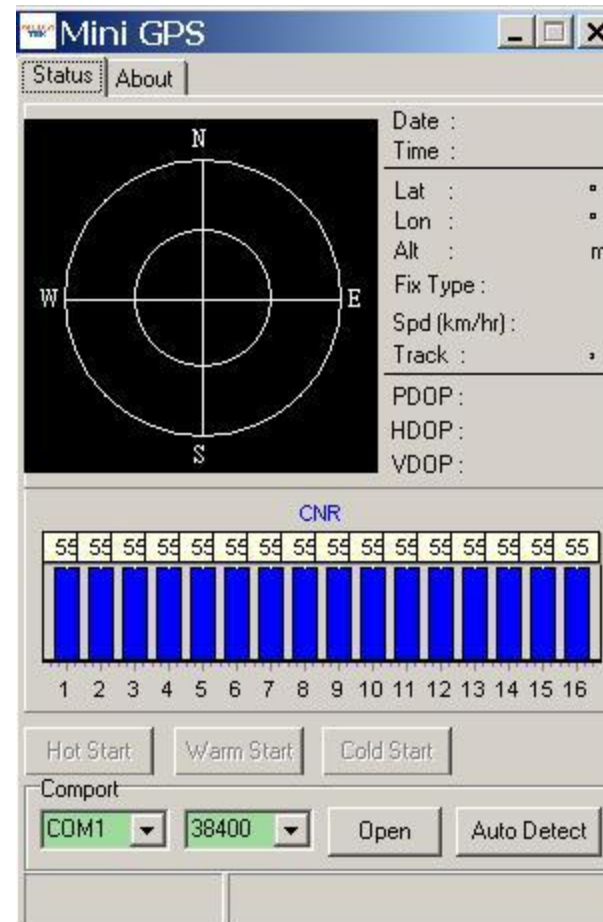

- Firmware Upgrade tool

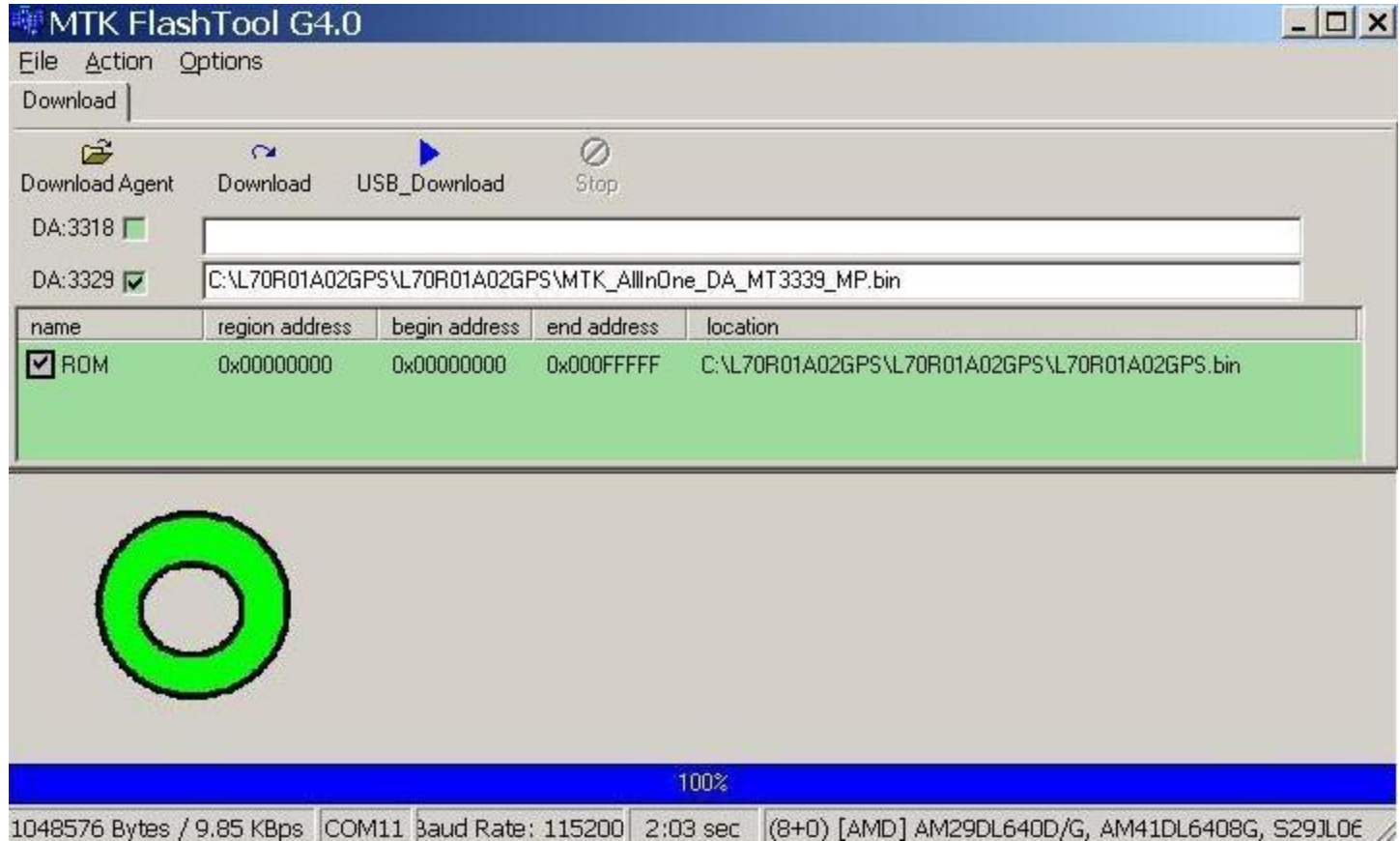

The screenshot shows the MTK FlashTool G4.0 application window. The title bar reads "MTK FlashTool G4.0". The menu bar includes "File", "Action", and "Options". The "Download" menu is open, showing options: "Download Agent", "Download", "USB_Download", and "Stop".

Below the menu, there are two download agent entries:

- DA:3318 [Empty text box]
- DA:3329 [C:\L70R01A02GPS\L70R01A02GPS\MTK_AllInOne_DA_MT3339_MP.bin]

A table displays the selected download agent's details:

name	region address	begin address	end address	location
<input checked="" type="checkbox"/> ROM	0x00000000	0x00000000	0x000FFFFF	C:\L70R01A02GPS\L70R01A02GPS\L70R01A02GPS.bin

At the bottom of the window, a large green progress indicator shows a 100% completion rate. The status bar at the very bottom displays: "1048576 Bytes / 9.85 KBps | COM11 | Baud Rate: 115200 | 2:03 sec | (8+0) [AMD] AM29DL640D/G, AM41DL6408G, S29JL0E".



Thank You!

info@quectel.com