



Shenzhen Hi-Link Electronic co., Ltd

HLK-M30 User Manual

Serial to WiFi Module

Catalog

1 Module Introduction	3
1.1.1 Brief Introduction	3
1.1.2 Module Features:	3
1.1.3 Module Parameters:	4
1.1.4 Application	5
1.1.5 Hardware	5
1.1.6 Pin.....	6
1.1.7 Mechanical Dimension.....	8
1.1.8 Antenna(optional)	8
1.1.8.1 External Antenna Parameter.....	8
1.1.8.2 Reference on-board PCB antenna	9
1.1.9 General development test suit.....	9
1.2 Typical Application	12
1.2.1 HLK-M30 typical circuit.....	12
1.2.2 MCU Simplest circuit.....	13
2 Function	15
2.1 Wireless.....	15
2.1.1 Work At STA Mode	15
2.1.2 Work At SoftAP Mode	15
2.2 Work Mode: Transparent transmission.....	16
2.3 Config Parameters.....	17
2.4 Firmware Update	17
2.5 GPIO.....	17
2.6 Network Protocol.....	18
2.6.1 Transparent transmission	18
2.6.2 AT command	20
3.Setting and using guide.....	21
3.1 Config by serial	21
3.1.1 Preparation work.....	21
3.1.2 How to Connect	21
3.1.3 Test Steps:	21
3.1.4 Communication test	24
4.1 Mode conversion	29
4.2 At command instruction	30
Appendix.....	33

1.1.1 Brief Introduction

HLK-M30 is a new low-cost embedded uart wifi module developed by Shenzhen Hi-Link Electronic co., Ltd

This product is an embedded module based on the universal serial interface network standard, built-in TCP / IP protocol stack, enabling the user serial port, wireless network (wifi) interface between the conversions.

Through the HLK-M30 module, the traditional serial devices do not need to change any configuration data can be transmitted through the Internet network. Provide a quick solution for the user's serial devices to transfer data via Ethernet.

This document as familiar with the HLK-M30 module and the test suite for guidance document. Please refer to << HLK-M30 AT Command.pdf >> and << HLK-M30 DataSheet >>

1.1.2 Module Features :

- ▶ Small size: 14mm × 16.5mm × 2.25mm
- ▶ Low power consumption; Quick start; network connect quickly
- ▶ Perfect support 802.11b/g/n
- ▶ Support all wifi encryption: WEP/WPA-TKIP/WPA-AES/WPA2-TKIP/WPA2-AES
- ▶ No driver need, User only need to use it as a serial port
- ▶ Support STA/AP mode
- ▶ Support TCP Server/TCP Client/UDP Server/UDP Client
- ▶ Support DHCP DNS HTTP
- ▶ Support serial at command also network at command
- ▶ Support search module in LAN

- ▶ Support SmartLink function,use app to config the module connect the wireless router
- ▶ CE/FCC support, ROHS standard support

1.1.3 Module Parameters :

Fig:1 HLK-M30 Module parameters

Basic	
Wireless	IEEE 802.11n、 IEEE 802.11g、 IEEE 802.11b
Wireless Rate	11n:up to 150Mbps 11g: up to 54Mbps 11b: up to 11Mbps
Channle	1-14
Frequency range	2.4-2.4835G
Send Power	15-18 DBM
Interface	UART、 GPIO
Antenna	
Antenna Type	External antenna
Distance	100-300m(different situation, different transmission distance)
Function	
WiFi mode	Sta/soft ap
Encryption	Wireless encrypton
	64/128/WEP encryption
	WPA-PSK/WPA2-PSK、 WPA/WPA2
Serial to Internet	
Max Serial rate	115200bps
TCP	Max connect:4
UDP	Max connect:4
Others	
LED	WIFI led
Environmental	operate temp:-20-70℃
	Operate humidity:10%-90%RH
	Store temp:-40-80℃
	Store humidity:5%-90%RH

1.1.4 Application

- ◆ The handheld device
- ◆ Remote control
- ◆ The consumer electronics
- ◆ IOT systems
- ◆ Industry systems
- ◆ Portable wireless communication product
- ◆ Medical equipment
- ◆ Led control
- ◆ Sensor network application
- ◆ Wireless printer

1.1.5 Hardware



HLK-M30 top

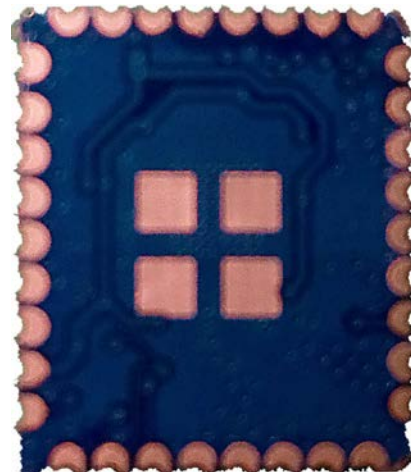

HLK-M30 back

1.1.6 Pin

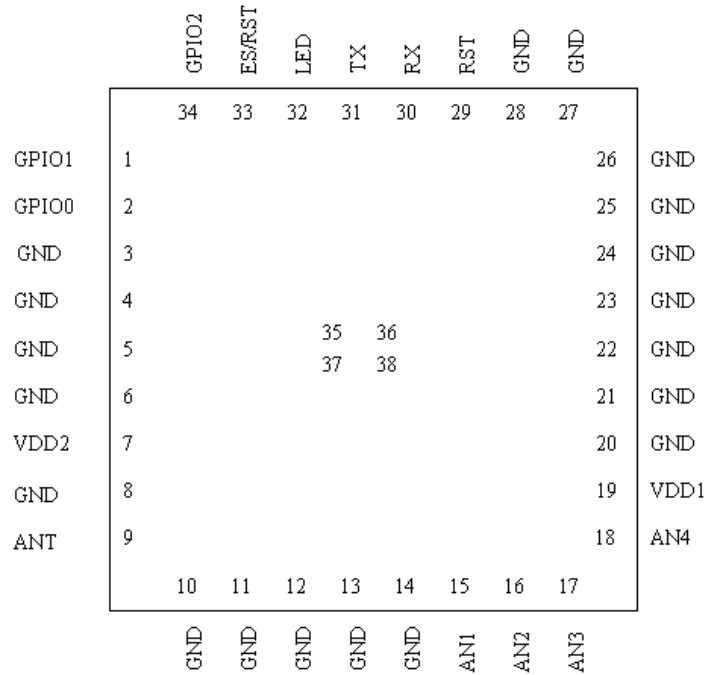

HLK-M30 PIN

HLK-M30 Pin Interface

Pin	Function	Derection	Description
1	GPIO1	I/O	General GPIO
2	GPIO0	I/O	General GPIO
3	GND	GND	Analogue Ground
4	GND	GND	Analogue Ground
5	GND	GND	Analogue Ground
6	GND	GND	Analogue Ground
7	VDD2	Power In	Supply Voltage, 3.3V+/-10%
8	GND	GND	Analogue Ground
9	ANT	-	Antenna Pin
10	GND	GND	Analogue Ground
11	GND	GND	Analogue Ground

12	GND	GND	Analogue Ground
13	GND	GND	Analogue Ground
14	GND	GND	Analogue Ground
15	AN1	-	Analogue Pin(Reserved)
16	AN2	-	Analogue Pin(Reserved)
17	AN3	-	Analogue Pin(Reserved)
18	AN4	-	Analogue Pin(Reserved)
19	VDD1	Power In	Supply Voltage, 3.3V+/-10%
20	GND	GND	Analogue Ground
21	GND	GND	Analogue Ground
22	GND	GND	Analogue Ground
23	GND	GND	Analogue Ground
24	GND	GND	Analogue Ground
25	GND	GND	Analogue Ground
26	GND	GND	Analogue Ground
27	GND	GND	Analogue Ground
28	GND	GND	Analogue Ground
29	RST	I	Reset Module
30	RX	I	UART RX
31	TX	O	UART TX
32	STA_LED	O	Staus LED
33	ES/RST	I	Exit/Default/Update
34	GPIO2	I/O	General GPIO
35	GND	GND	Analogue Ground
36	GND	GND	Analogue Ground
37	GND	GND	Analogue Ground
38	GND	GND	Analogue Ground

Note:

1. The voltage of GPIO is 3.3V.

Impedance	50 Ohm
VSWR	2 (Max)
return loss	-10dB (Max)
Connection type	I-PEX or Onboard

1.1.8.2 Reference on-board PCB antenna

If permit, you can use the PCB onboard antenna. See the Appendix PCB document of PCB antenna. Below is the 2.4G PCB board recommended:

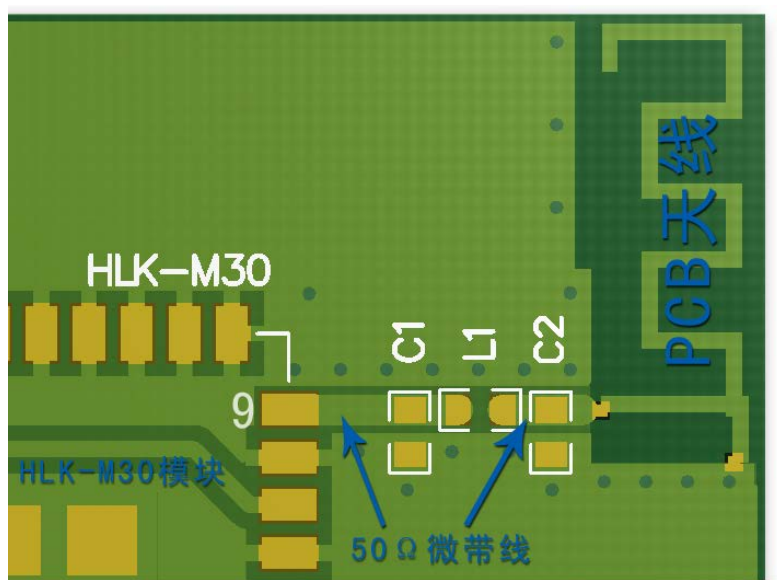

Note: C1, C2 do not need weld, L1 uses 0 ohm resistor or capacitor 10pF
 The top and back o PCB antenna part can not be connected to GND
 The PCB antenna must placed on the edge of the board
 please do impedance matching, 50 + 5 Omega impedance

1.1.9 General development test suit

We provides the HLK-M30 Startkit, for the customer to quickly familiar with the product and in-depth application development. The figure below shows the general assessment of development and test suite appearance, users can debug module through the RS-232 serial port by computer, and also configuration parameters.....

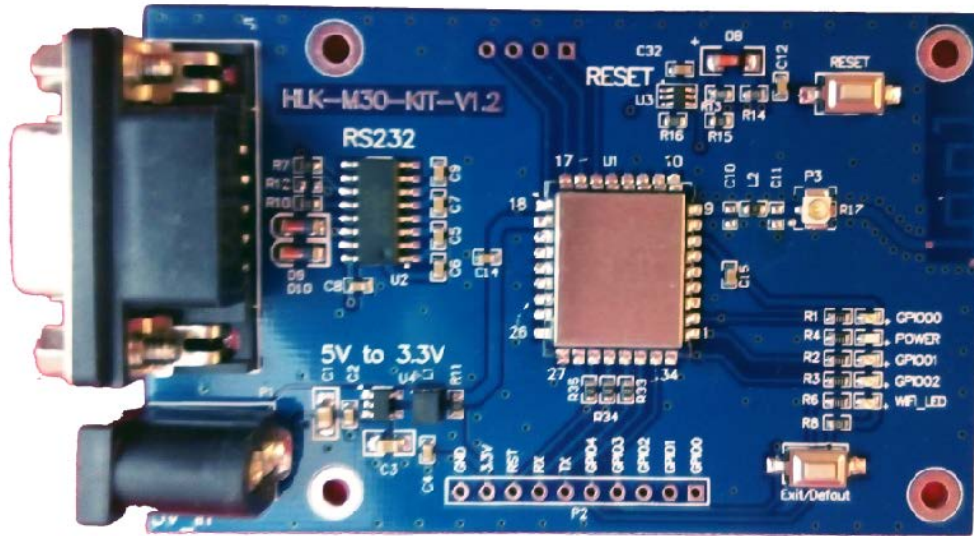

HLK-M30 StartKit

StartKit Interface

Fuction	Name	Item	Description
Interface	DB9	J1	RS232 interface,can
	DC5V	P1	5V input, min:3.8, max:5.5V
	10pin	P2	HLK-M30 module's pin
	IPEX	P3	Antenna IPEX
	SPI interface	P4	Burn firmware into the flash(customs can not use)
LED	GPIO00	GPIO00	Connect to the HLK-M30 GPIO0; When GPIO0 at low voltage the LED will light up; This can test thee GPIO0 output;
	POWER	POWER	3.3V power led; If this led do not light up,please check the power supply
	GPIO01	GPIO01	Connect to the HLK-M30 GPIO1; When GPIO1 at low voltage the LED will light up; This can test thee GPIO1 output;

	GPIO02	GPIO02	Connect to the HLK-M30 GPIO2; When GPIO2 at low voltage the LED will light up; This can test thee GPIO2 output;
	WIFI_LED	Indicate LED	WIFI LED, indicate below: Flash 2 times (cycle): The moduel staus:STA SmartConfig Staus; Flash 3 times (cycle): The moduel staus:STA Manual Staus; Extinguishing: Module have connect to the wireless router(No communication data); Random flash: when receiving or sending data, broadcast data, LED will flash once corresponding Fast blink: When use IoTManager config the module,when successful it will fast blink;Or there are huge Data communication Flash 4 times: The module are now get DHCP.
Button	Reset	RESET	Reset button,Press the module will reset.
	Exit/Default	Exit/Default	Short press(0.5-5s): Enter at command mode Long press(More than 6s): Back to factory

1.2 Typecal Application

1.2.1 HLK-M30 typical circuit

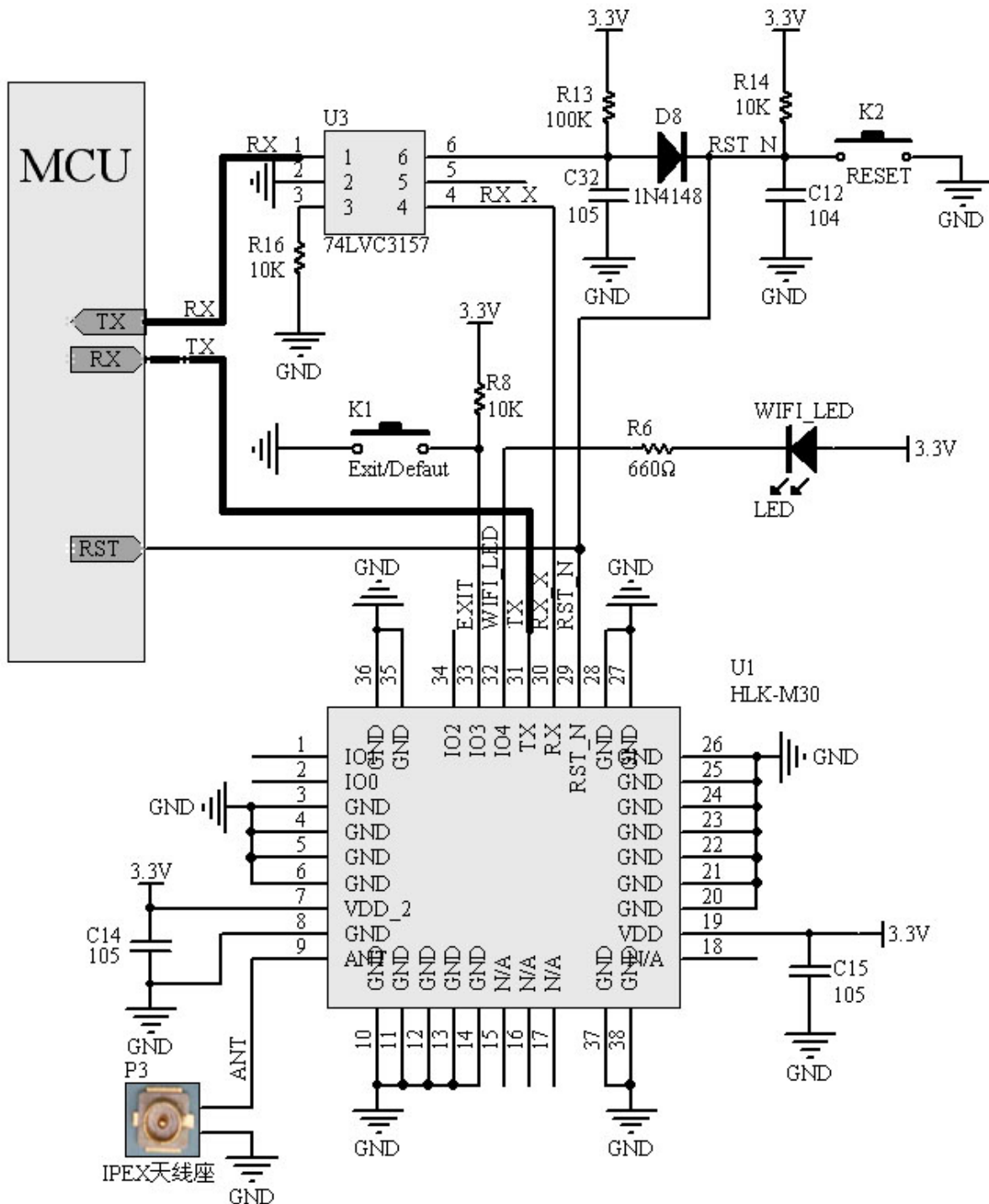

Figure 7. HLK-M30 typical circuit

<Descripton>:

MCU custom's microchip or serial enddevice or serial chip,the interface voltage is 3.3V TTL.

RX/TX The module's receive/send pin

74LVC3157(U3) Analog switch.This IC cannot be removed,it will help to boot the module

RESET(K2) Reset button.Press it the module will restart.

WIFI_LED Indicate LED

Exit/Default (K1) Short Press:exit transparent transmission.

Long press(more than 6s):back to default seeting

IPEX (P3) Antenna interface,make sure the matching 50 + 5 Omega impedance

1.2.2 MCU Simplest circuit

Below is there is a mcu to control the hlk-m30's RX pin,the smallest circuit.In this circuit you can remove the 74LV3157.because this IC's fuction is replace by your mcu.Do like this:

Power On → Use your mcu's GPIO to pull down the voltage of hlk-m30's RST and RX pin →

Release RST_N pin → Wait for at least 50ms than release RX pin → Module StartUp

The time between RX and RST pin is controlled by your MCU.

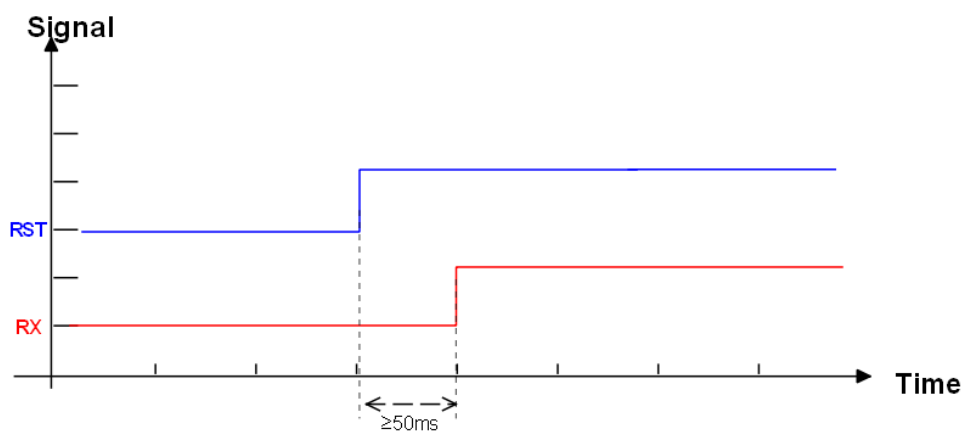

HLK-M30 Startup sequence diagram

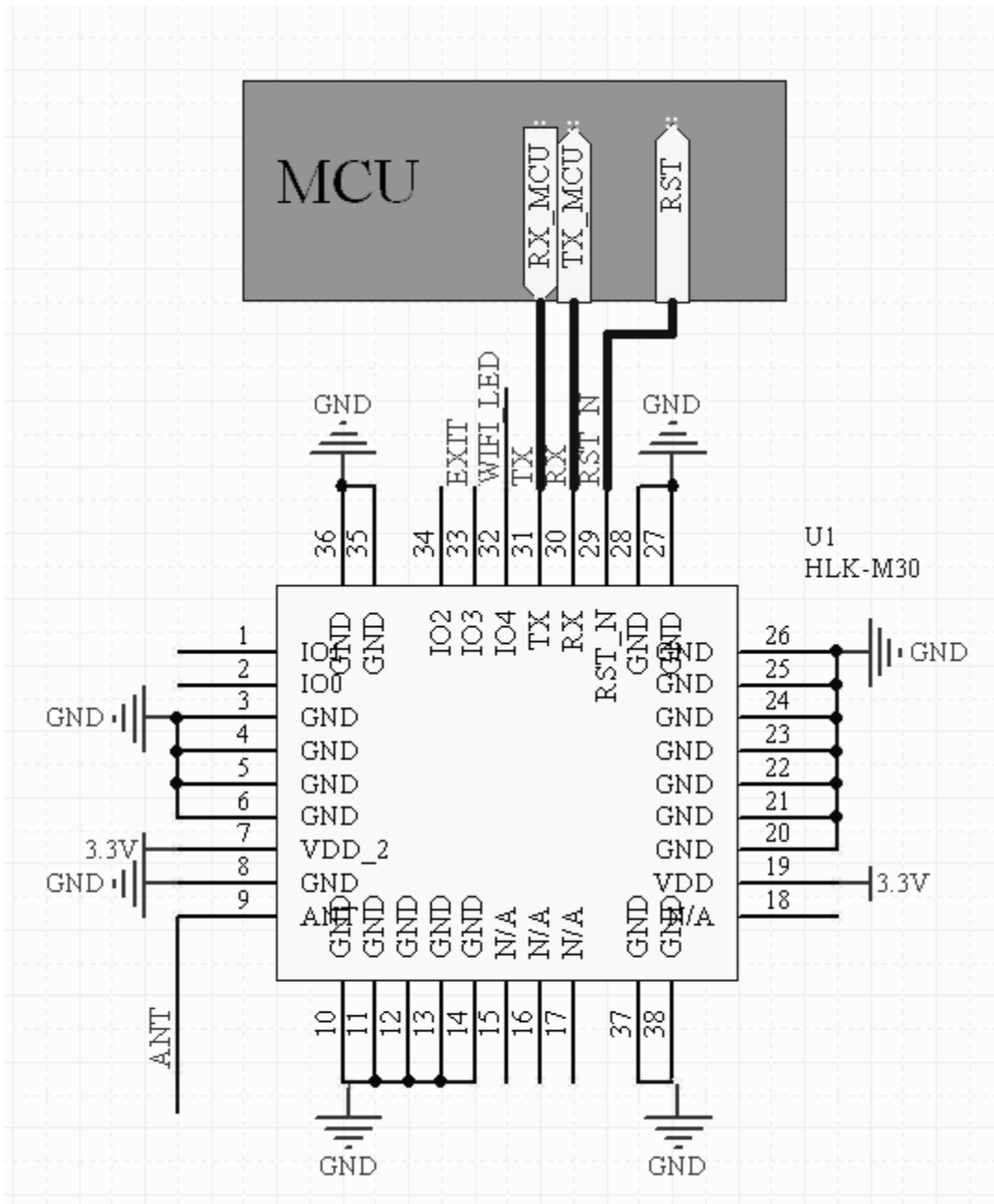

HLK-M30 Smallest Circuit

2 Function

2.1 Wireless

HLK-M30 can be configured STA or AP mode. So,there are two serial to wifi mode:serial to WIFI(STA mode) and serial to WiFi(SoftAp mode)

Note:

AP: The center of a wireless network node. Commonly was a wireless router.

STA:Wireless node,a enddevice,like notebook,PDA are both STA device.

2.1.1 Work At STA Mode

This is the basic wireless network,A ap connect all the STA device together,See the below picture, communication between the STA forward by AP,In this mode,HLK-M30 work at STA mode,by some proper settings, the data can transfer between the serial and wifi.

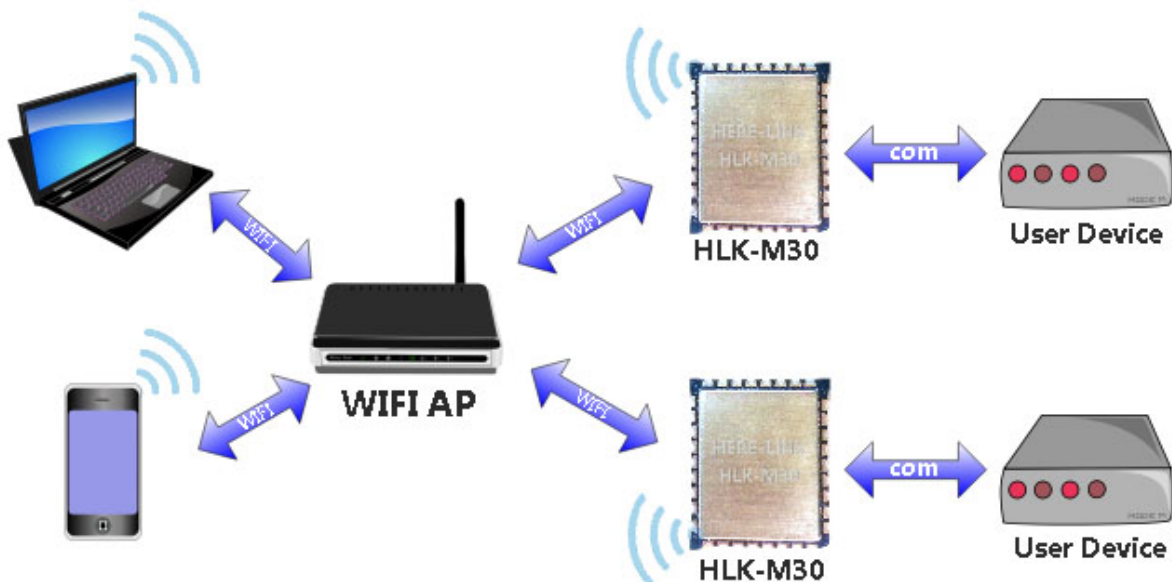

HLK-M30 Sta Work Topology

2.1.2 Work At SoftAP Mode

HLK-M30 works in AP mode, the PAD, mobile phone, computer and other equipment can directly connect to the module, That means the user can convenient to monitor their equipment.

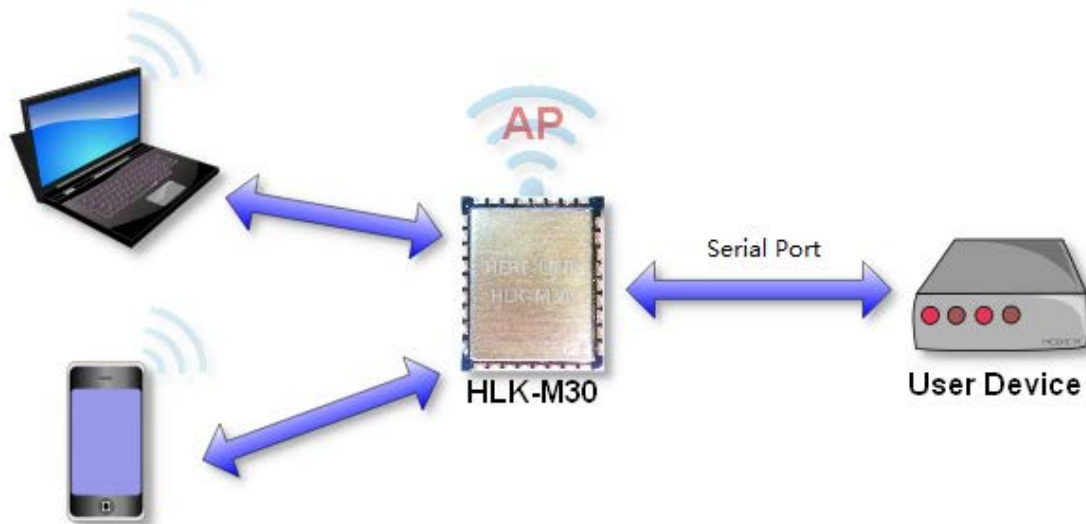

HLK-M30 SoftAP topology

2.2 Work Mode: Transparent transmission

The HLK-M30 supports serial transparent transmission. This has the advantage of plug and play serial, to reduce the user's complexity. Module in transparent transmission mode, the user only need to configure the necessary parameters. After power on, module automatically connect to the default wireless network and server.

Because in this mode, the module serial port always work in transparent transmission mode, so the user just use it as a virtual serial port. In short, the module is a wireless serial port, without any change, the user's equipment can be easily add wireless data transceiver

Transparent transmission mode is fully compatible with the user's own software platform, reduce integration of wireless data transmission software development. You should to config the below parameters at STA Manual mode:

- ◆ Wireless Parameters
 - Target AP's SSID and SSID'S length.
 - Target AP's encryption
 - Target AP's key and key's length
- ◆ TCP/UDP parameters
 - Network Protocol
 - Remoto IP

- Port
- ◆ Serial Parameters
 - Bandrate
 - Data length
 - Checksum bit
 - Stop bit

2.3 Config Parameters

HLK-M30 can config by at command,Learn more you can find << HLK-M30 AT Command V1.2>>

HLK-M30 also can be configed by UDP/988 port,When you establish udp,you can send at commad by network,learn more you can see the “ at+DP” command.

2.4 Firmware Update

HLK-M30 supprt serial port to update firmware.Use tool:HLK_M30_update.exe.Steps below:

1. Open HLK_M30_update.exe,Change the name of the firmware to HLK-M30.img,copy it to the same directory of the HLK_M30_update.exe tool.
2. Press C to choose update serial port.
3. Press “Enter”to let the tool to start update.
4. Connect the serial prot,Press the Exit/Reset/Update button and then power on,Wait for 1s then release,the tool will load the firmware.
5. When update complete,the module will restart.

2.5 GPIO

HLK-M30 supply three GPIO to use,These GPIO can control by serial at command,and also can be controlled by UDP.

HLK-M30 GPIO

GPIO	Function	Feature	Type
GPIO00	Output/Input High/Low Voltage	Write/Read by at command	I/O

GPI001	Output/Input High/Low Voltage	Write/Read by at command	I/O
GPI002	Output/Input High/Low Voltage	Write/Read by at command	I/O

For example:

At+GW=0,1 GPIO0 Output High Voltage
 At+GR=2 Query GPIO2 Input Voltage

Udp Control below:

when the module have connect to the ap.Then establish udp client, prot is 988,in default setting,you can send:hlkATat+GW=0,1\r,the GPIO0 will output high voltage

2.6 Network Protocol

The serial to network have two method: Transparent transmission,at command

2.6.1 Transparent transmission

There are 4 mode of serial to network: TCP Server、TCP Clinet、UDP Server、UDP Client。

TCP Server

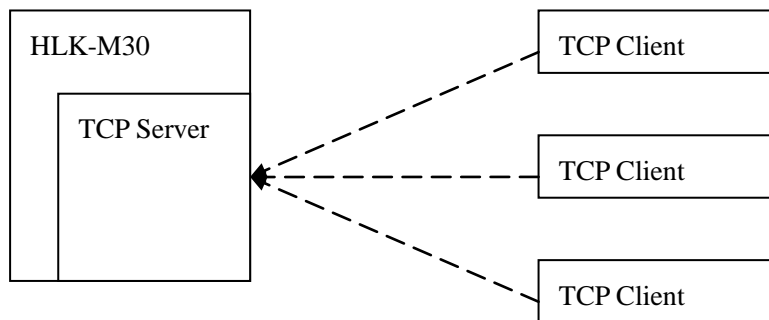

Fig10.TCP Server

In this mode,HLK-M30 is waiting for the TCP Client connection.All TCP data is sent directly to the serial port.Serial data is transmitting to all TCP Clieen terminal.

The HLK-M30 support 4 tcp client.

TCP Client

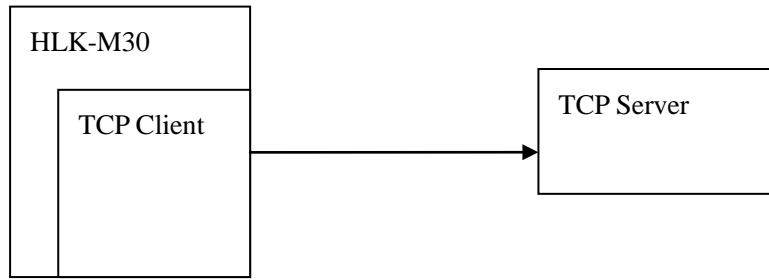

Fig11.TCP Client

In this mode, the HLK-M30 will connect the remote domain or ip. All TCP data is sent directly to the serial port.Serial data is transmitting to the tcp server

Abnormal network disconnect can cause module active reconnection. When enable TCP reconnection function, TCP Server active disconnected, module will immediately active reconnection, otherwise the module will not reconnect

UDP Server

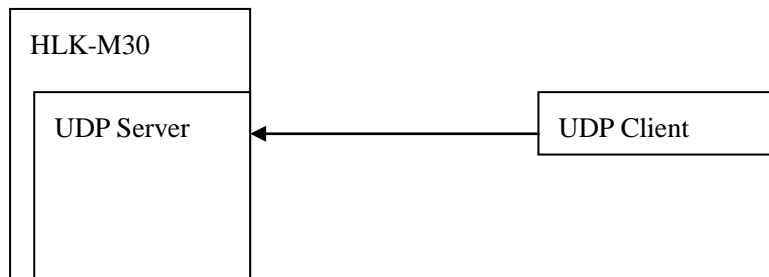

Fig12.UDP Server

In this mode,Module will listen local udp port, Upon received data from this port, the data will be sent to the serial port, and record the distal IP,Port.The module will only record the last connection remote information. Serial receive data will be sent directly to the recorded distal IP, Port.

UDP Client

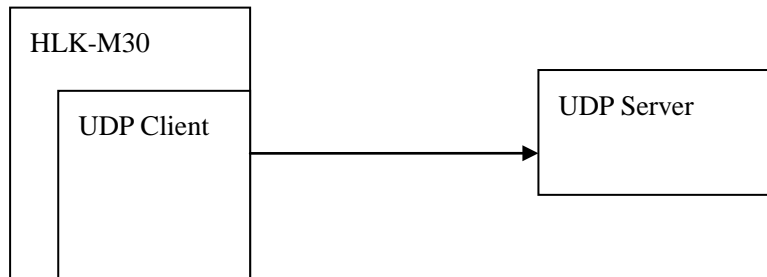

Fig13.UDP Client

In this mode, serial data will be sent to the configed IP, port.The data recevied from the server will be sent the serial port terminal.

2.6.2 AT command

We provides the at command to achieve the function of sending and receiving network d ata. This functionality is implemented through socket related instructions.

The basic process is as follows

- 1) Socket open
- 2) Socket write
- 3) Socket read
- 4) Socket list
- 5) Socket close

3.Setting and using guide

3.1 Config by serial

3.1.1 Preparation work

- ◆ Hardware:
 - HLK-M30 module
 - HLK-M30 motherborad
 - 5V power
 - Serial cable
 - Wireless router
 - Cumputer
- ◆ Software
 - HLK-M30_CONFIG tool
 - Serail&TCP_UDP test tool

3.1.2 How to Connect

Below is the general development kit for communication test. Need a serial computer, no serial port machine can use a USB to serial cable. Connections are as follows:

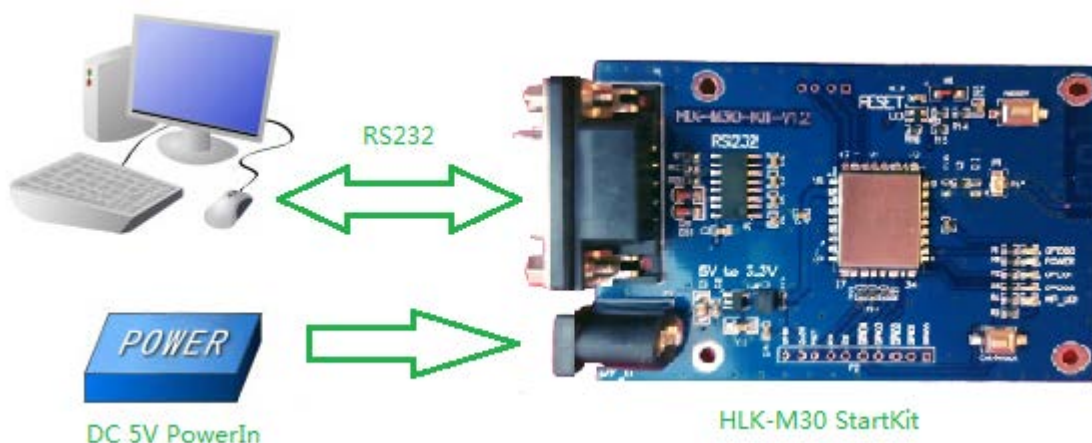

Connection of the testboard

3.1.3 Test Steps:

- 1.PowerOn the wireless router.We set the wireless parameter as below:

- ◆ Wireless name:(ssid):HI-LINK_Guest
- ◆ Encryption:WPA2_AES
- ◆ Key:hlktech123
- ◆ DHCPD:191.168.16.100
- ◆ 网关:192.168.16.254
- ◆ DNS:192.168.16.254

2,Connect the DB9 of startkit with your computer's DB9, then power on,the wifi led will flash.



HLK-M30_CONFIG-English

HLK-M30_CONFIG

ShenZhen Hi-Link ElectronicTe

,Software

3.Open“HLK-M30_CONFIG-English”,

interface as follows:

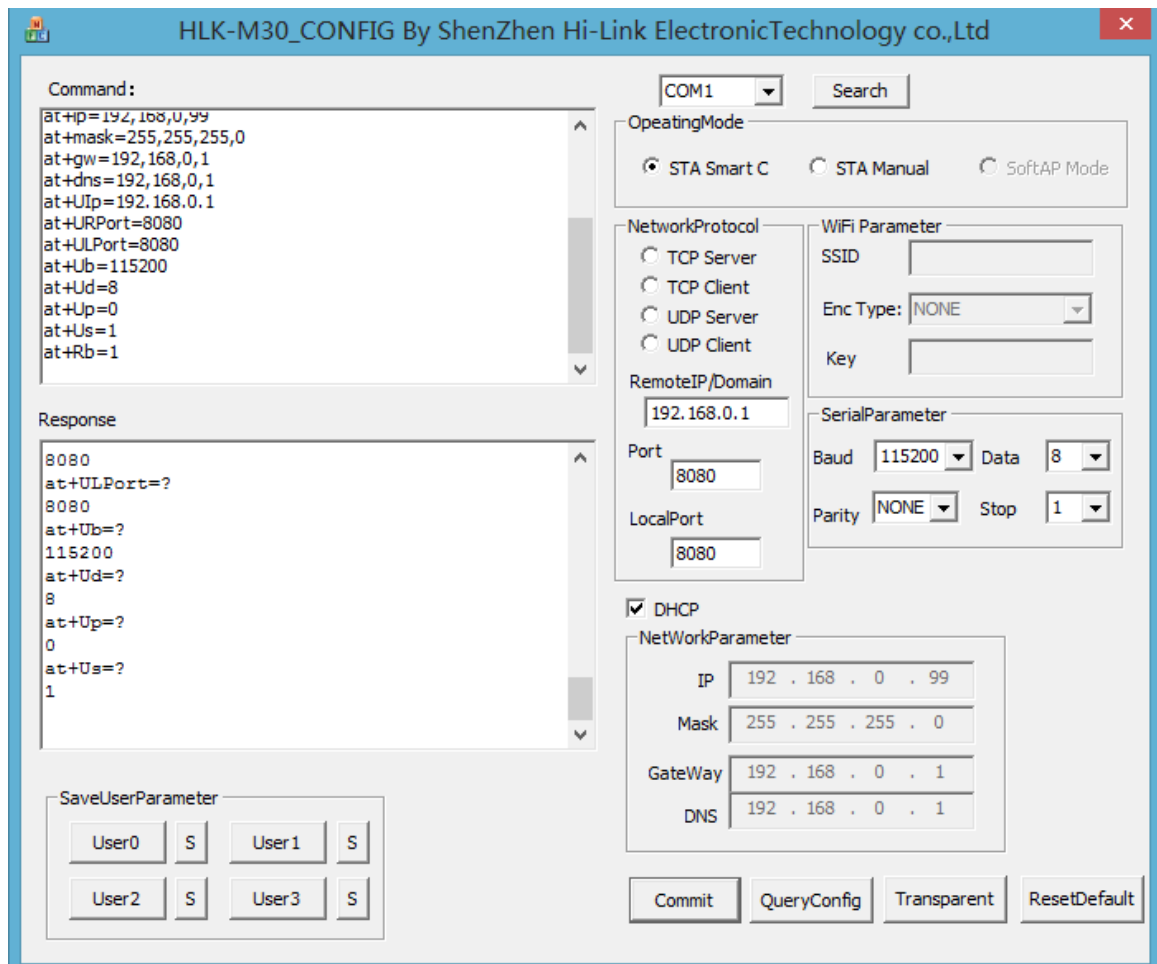

HLK-M30_CONFIG Interface

4,Chose the right COM port



,Press the “Exit/Default” button on the

starkit board,and then press the button “Search” ,it will back:Find Device at COM1(115200)



5,Press QueryConfig button,the software will list the current parameters

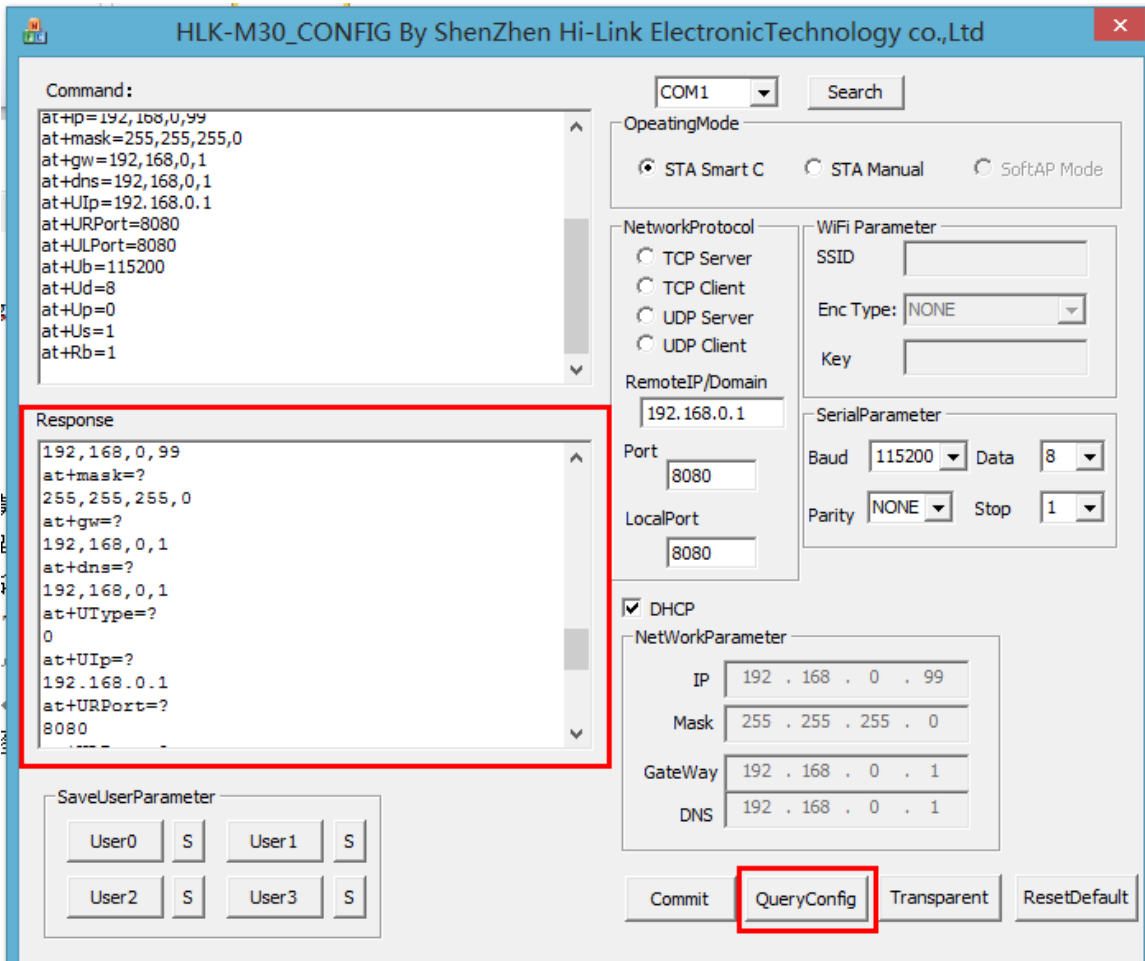

6,Change the parameters.We config the module parameters as below:

Work Mode:STA Manual,

Ssid:HI-LINK_Guest WPA2 /AES

KEY:hlktech123.

Network:TCP SERVER. Port:8080

Disable DHCP,Choose Staic IP.

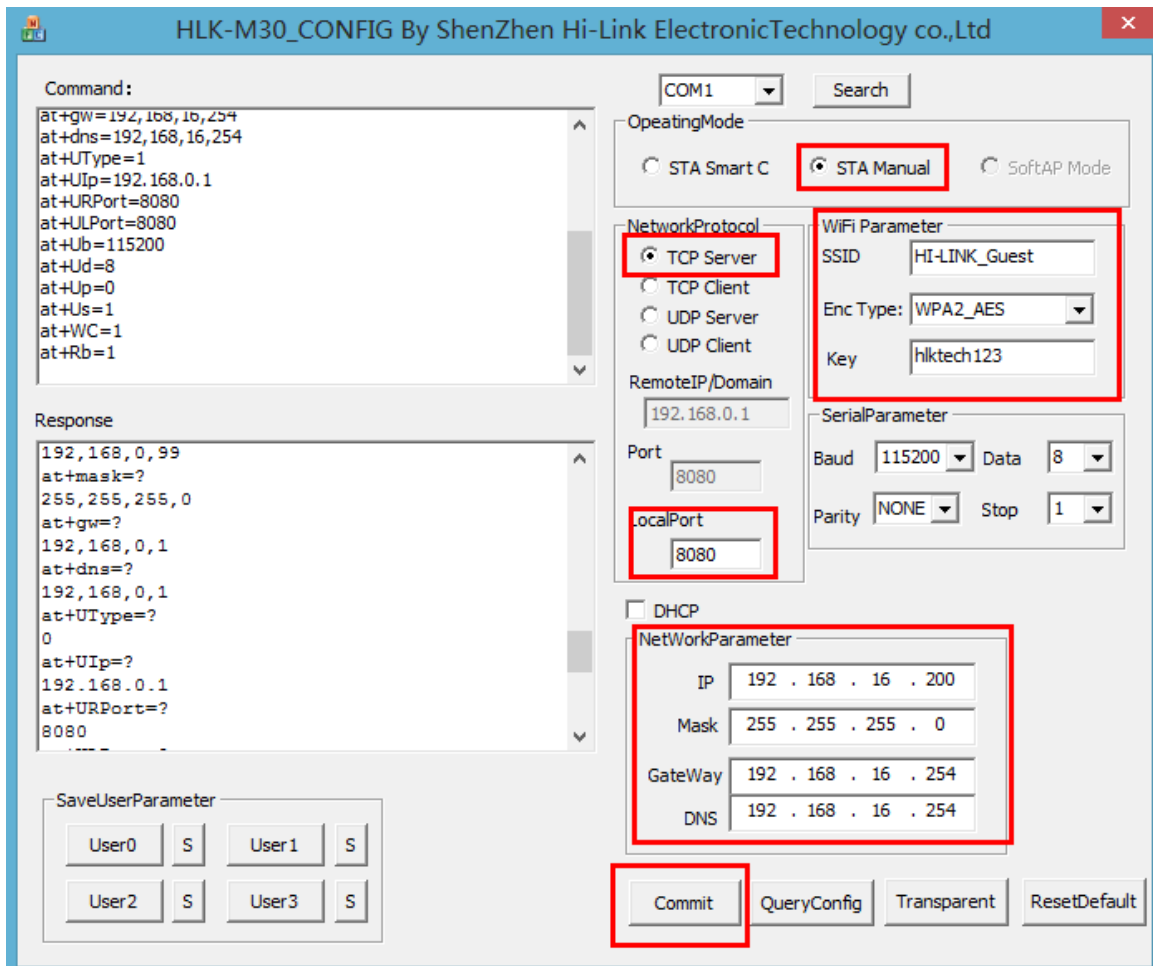

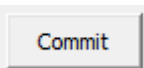
7, Press Commit , the command will send to the module. Command and response area will display the status of command will send and execution.

3.1.4 Communication test

8, Till now the module have connect to HI-LINK_Guest. So we open serial and TCP/UDP test tool to test the communication.



Serial&TC
P_UDP
Tool

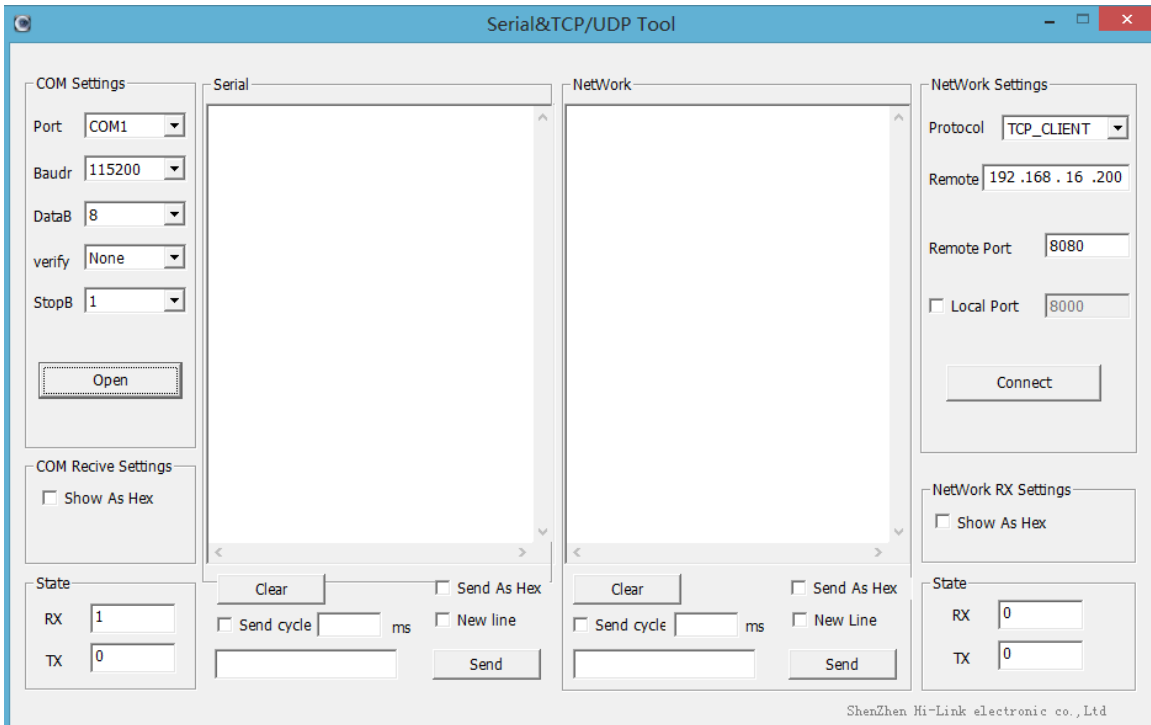

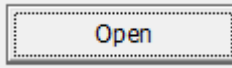
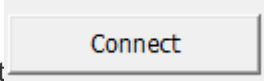
9. Open the COM port , type in the ip address and the 8080 port of the module, press connect , and send data to each other, you can see both have received data

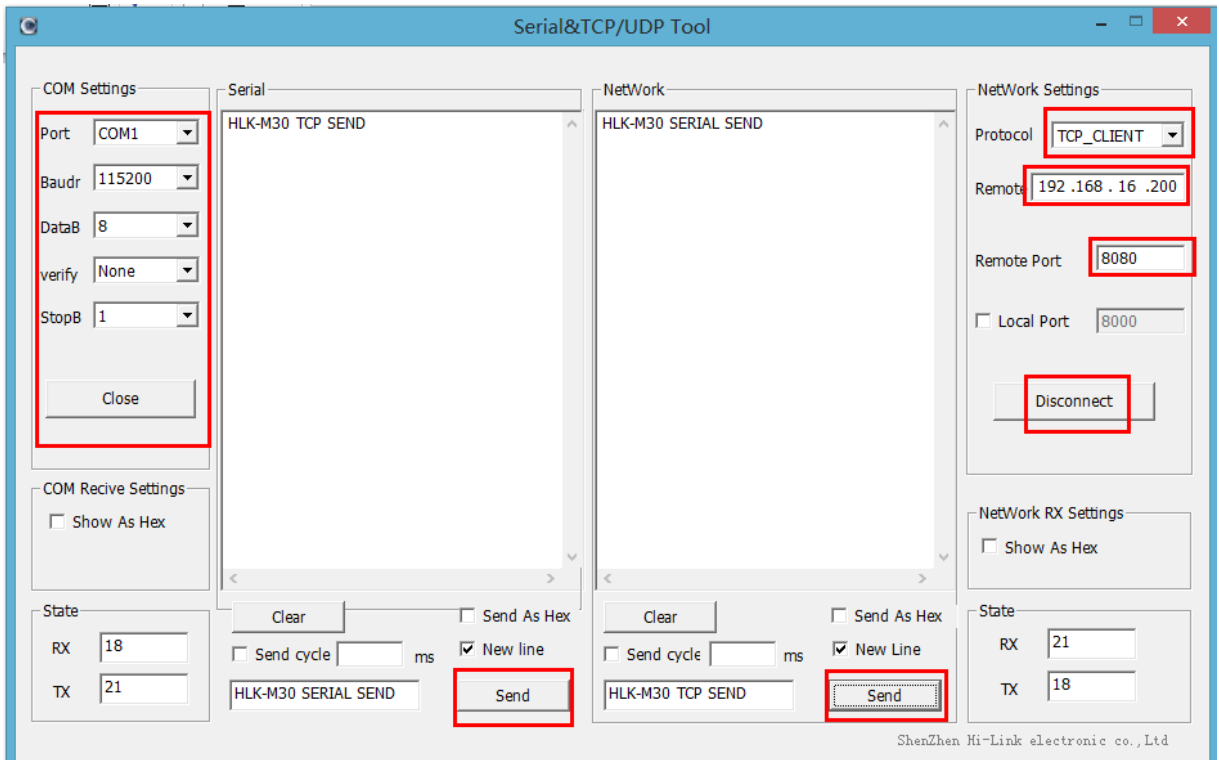

10,The serial port send:HLK-M30 SERIAL SEND to wifi,and the wifi received the data.The TCP send:HLK-M30 TCP SEND to serial port and the RS232 port have received the data.

3.2 SmartConfig

1 Preparation work:Install“IoTManager_v0.96”



on your

android phone .Then, power on the HLK-M30,Press the”Exit/Default” button at least 6 second,this will make the module return to factory setting.

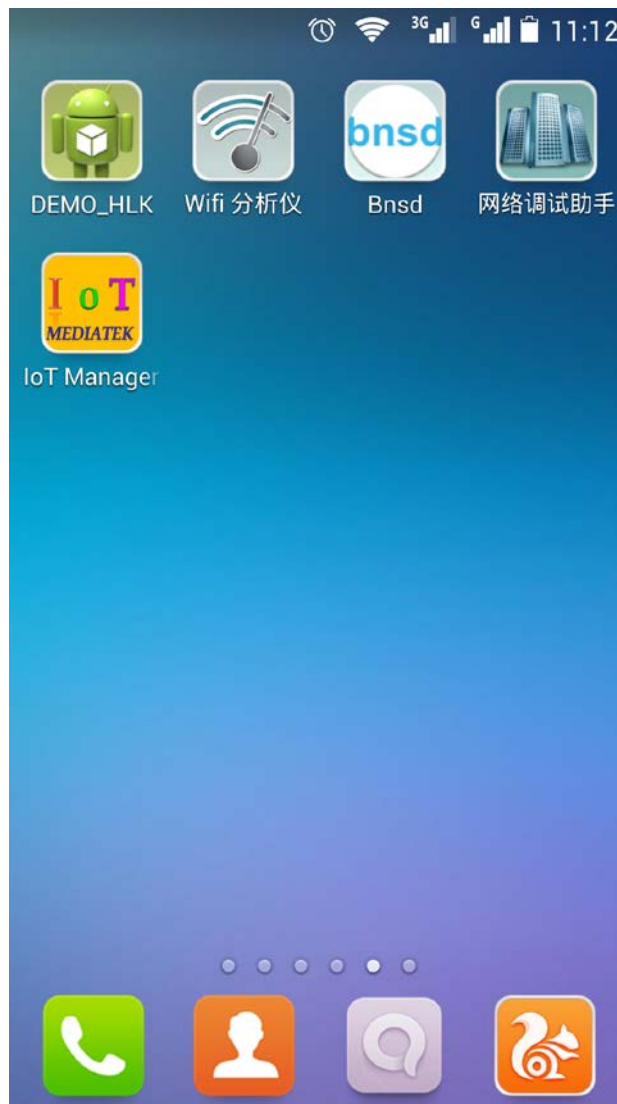

2. Open IoTManager,type in the target wireless router’s ssid and passwork, observe the WIFI-LED blink two times out of a cycle,that means the module is in smartconfig mode,and then

press start button: ,this will config the module connect to the wireless router,when the WIFI-LED is quickly flashing,that mean the module have connected to the router.

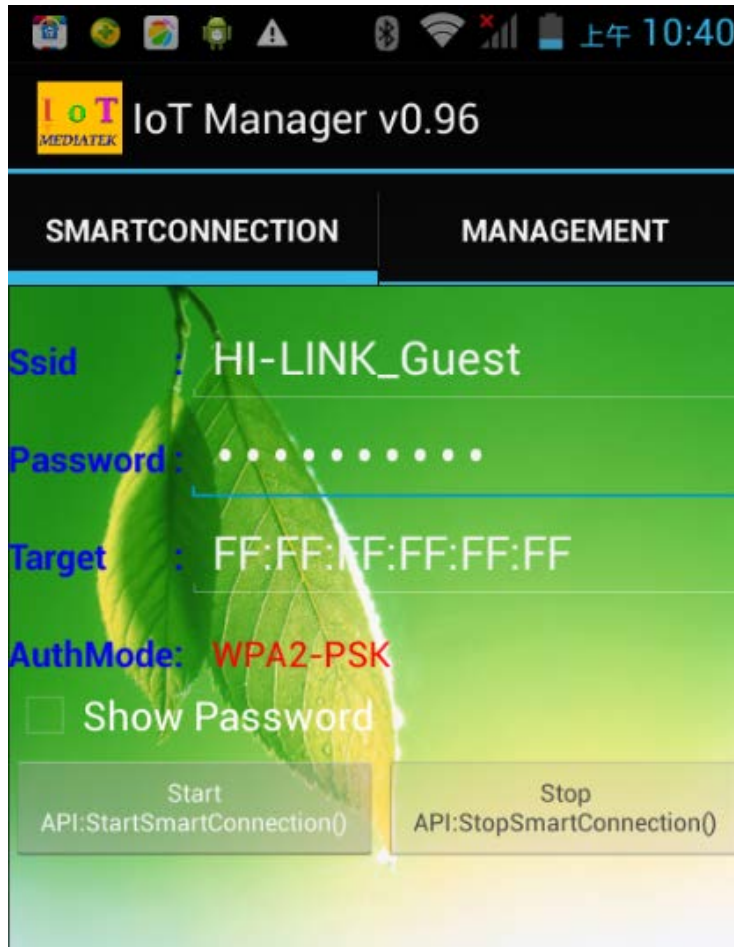

3,Let you notebook also connect to the same router,Open our search tool:HLK-M30_Discover



HLK M30 Discover 搜
索局域网内模块工...
HLK-M30_Discover

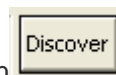

,Press "Discover" button ,You can find all the wifi modules from our company,See below:

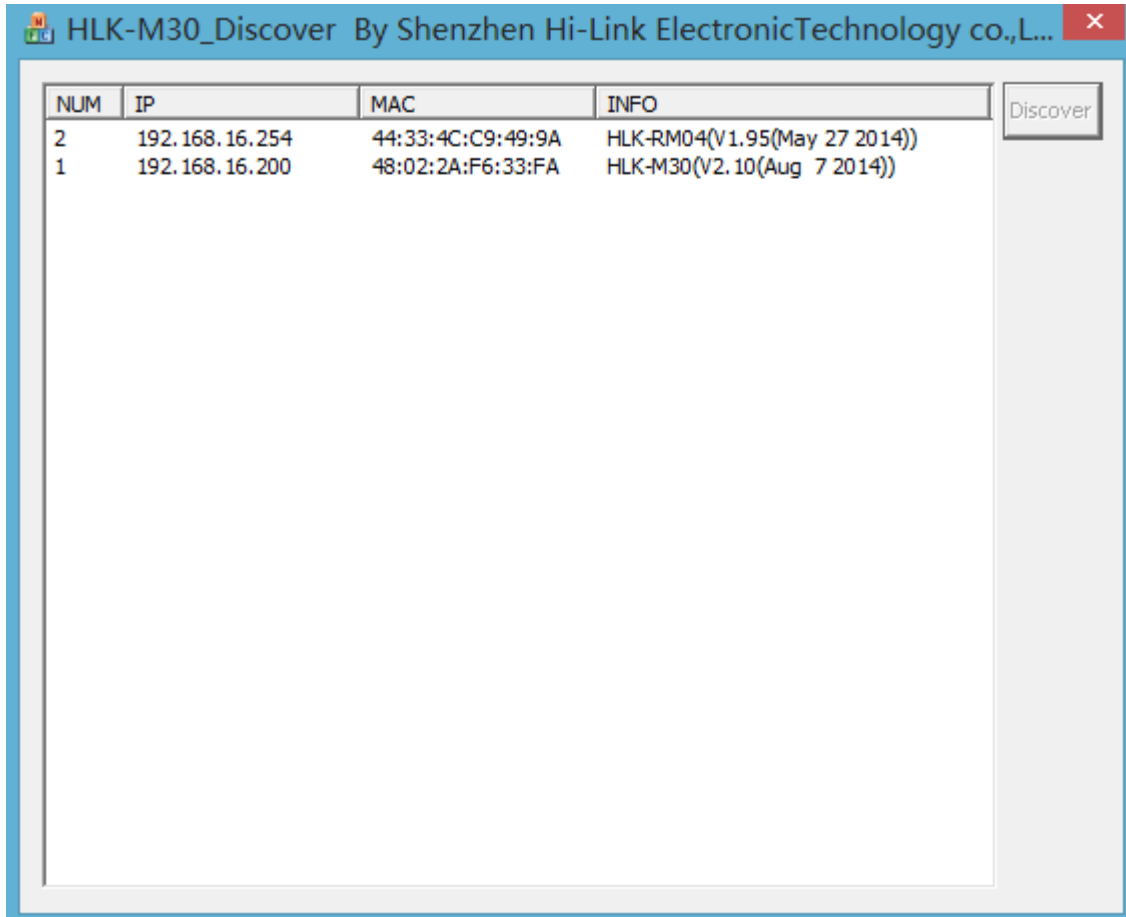

Note:

HLK-M30 factory setting is Smart Config. When power on, you can use this tool to config the module

3.3 Applications

3.3.1 Wireless remote control

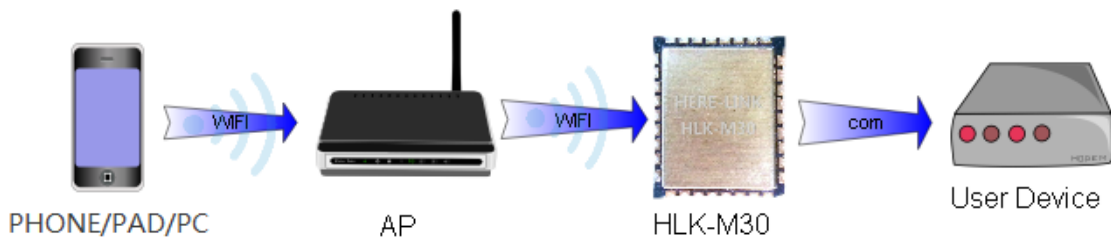

In this application, the HLK-M30 in STA mode connects to AP, the HLK-M30 serial connected to user's equipment. Mobile phone, PAD or computer is connected to the AP, and then through the wireless network to control the user's equipment.

3.3.2 Remote connection

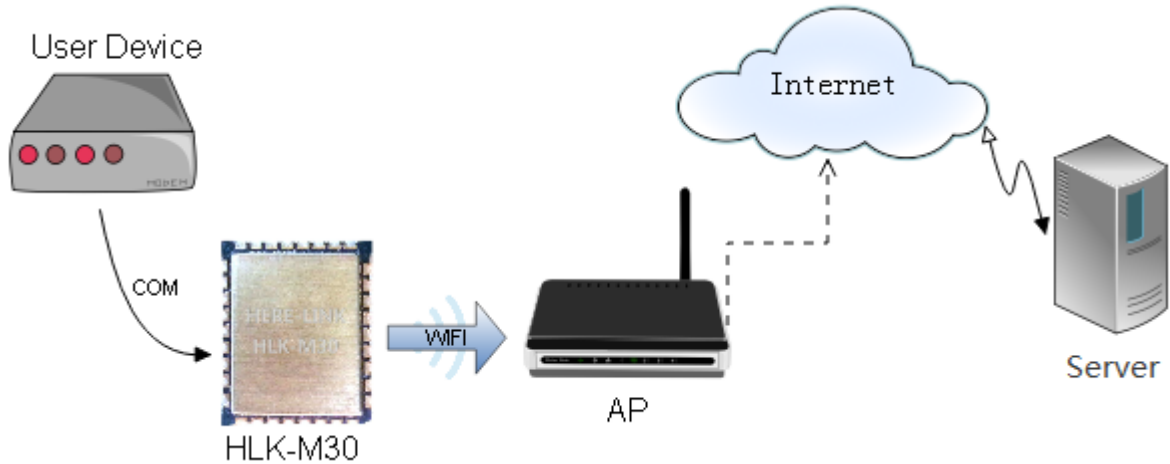

The HLK-M30 module as STA, connect to the Internet through the gateway(AP). Module is set to TCP Client, points to the server, the server is set to TCP Sever.The user device is connected to HLK-M30 through the serial port, and its data can be sent to the server to process and storage.The service can send commands to control the user’s equipment

4. At command Instruction

4.1 Mode conversion

When HLK-M30 module power on,it will enter transparent transmission mode,you can pull down the voltage of the ES/DST pin to let the module enter AT mode.Transparent transmission mode and at mode can change like this:

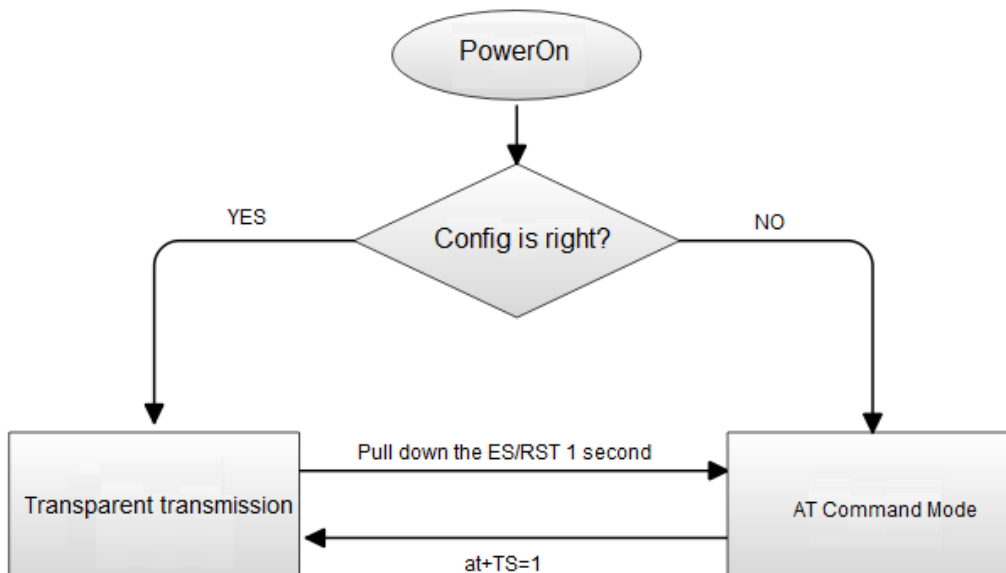

Serial Port Work Mode

When power on,the module will check the config of the network,if it can connect to the internet it will enter transparent transmission,if not,it will enter at command mode.

The method of change the transparent transmission mode to at command mode:pull down the voltage of the ES/RST pin more than 0.5s less than 5s,it will enter at command mode.If you pull down the ES/RST pin more than 6s,the module will back to factory config.

Send at+TS=1,the module will enter transparent transmission mode.

4.2 At command instruction

At at command mode,you can config the module by at command,the at format like below:

at+[command]=[value]\r, There need "\r", otherwise it will be considered wrong at instruction.

According to the different command module will return a different value

For example:"at+Ulp=192.168.11.133\r" Set the remote ip address:192.168.11.133。

"at+Ulp=?\r" Query the remote ip address 。

at command below:(Instruction is case sensitive)

KeyWord	Function
WA	Wifi mode,ap/sta
WM	Wifista method>manual or smartconfig
Sbssid	set target ap bssid
Sssid	set target ap ssid
Sssidl	set target ap ssid length
Sam	set target ap encryption method
Spw	set target ap key
Spwl	set length of target ap key
WC	calculation PMK
dhcp	set dhcp or static
ip	static ip
mask	Static mask
dns	Static DNS
gw	Static gateway
Ub	Set uart bandrate
Ud	Set uart datalength
Up	Serial parity bit
Us	Serial stop bit length
UType	Set TCP or UDP
Ulp	Set remote ip address
URPort	Set remote port

ULPort	Set local port
UPL	Set or query data length of automatic framing
UPT	Set or query period of automatic framing
UPT2	Set or query Interval period of automatic framing
DP	Prefix data for UDP/988 port executes the at command
DE	UDP/988 port executes the at command enable or disable
Rb	Reboot the module
ver	version
Df	Back to default setting
SO	Socket open
SC	Socket close
SL	Socket check
SW	Socket send
SR	Socket read
DR	Domain name resolution
GW	GPIO write
GR	GPIO read
TS	Transparent ransmission change
mac	Get mac address

Note: The at instruction are case sensitive. "at" the two character is lowercase.

More details of AT Command,you can refer to:<< HLK-M30 AT Command V1.2>>

HLK-M30_CONFIG tool Details:

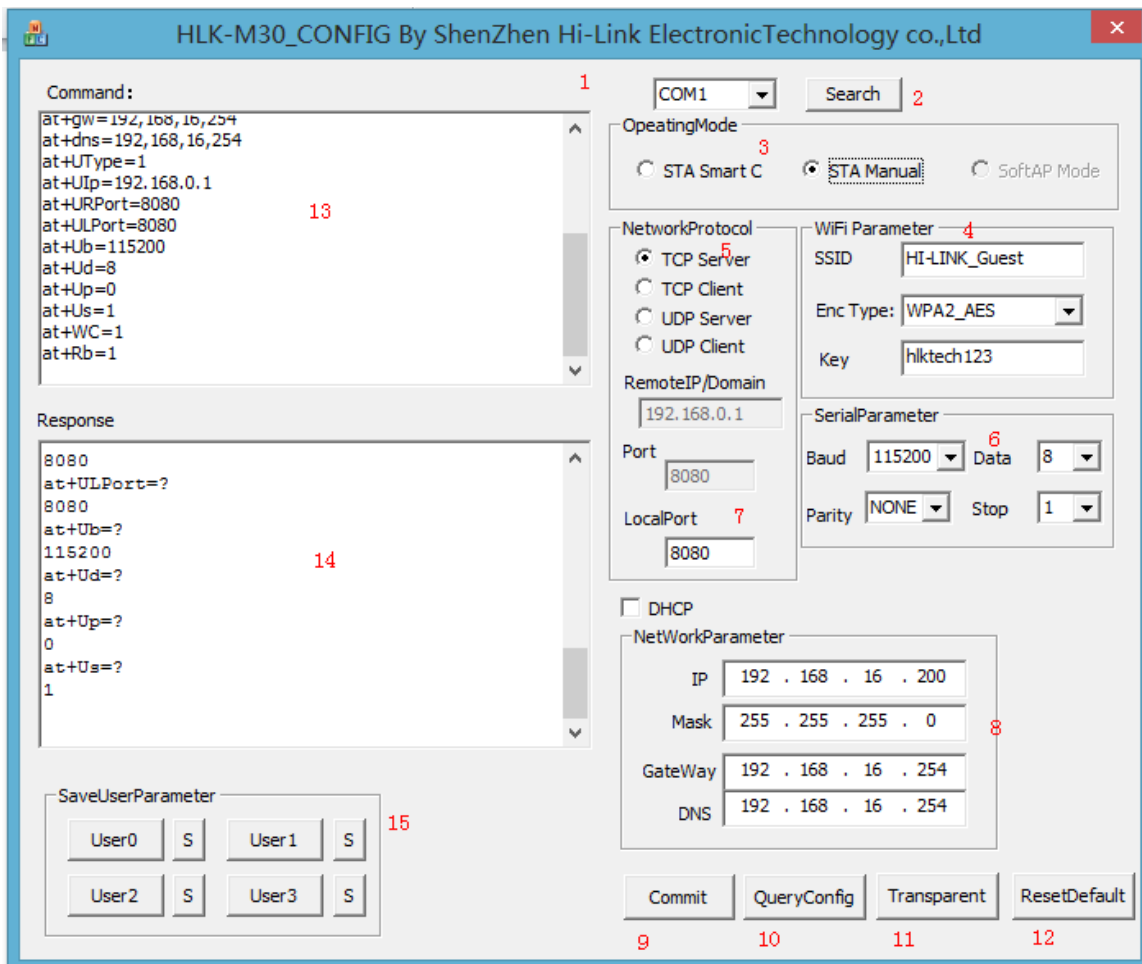

Interface description:

1. Choose Com port
2. Search module button
3. Choose module's work mode
4. Wireless Parameters
5. Choose network Protocol
6. Serial port parameters
7. Remote/Local port
8. Network IP
9. Submit the configure button
10. Query the configure button
11. Enter the transparent transmission button
12. Back to factory setting button
13. Waiting to send AT command zone
14. At command execue returns area
15. Save user parameter button.

Appendix

Document history

version	Records	Date
V1.1	Draft version	2014-8-10
V1.2	Add UDP at command decription	2014-9-20