

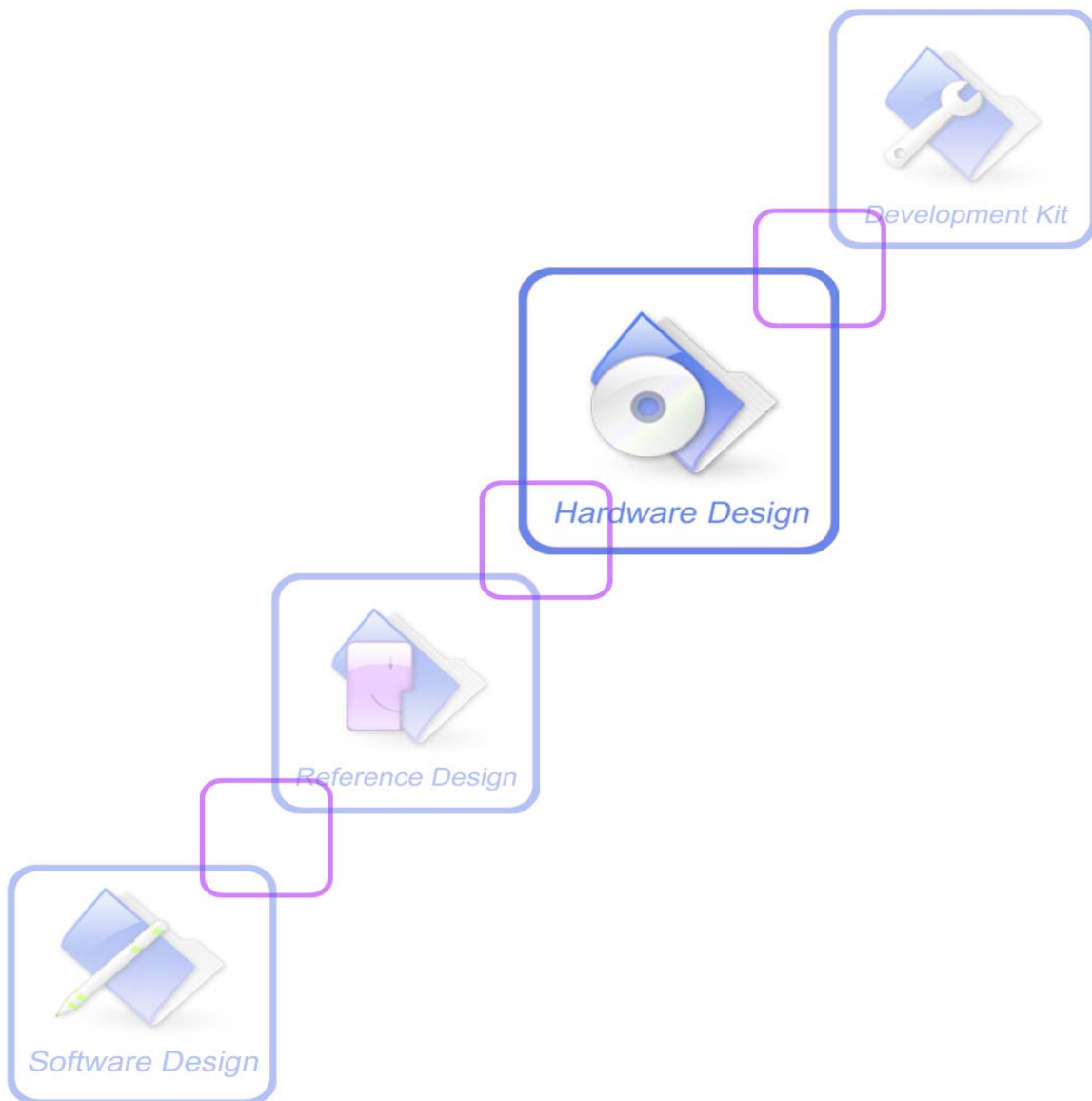

A company of SIM Tech

SIM908_Hardware Design_V1.05



Document Title	SIM908 Hardware Design
Version	1.05
Date	2011-09-22
Status	Release
Document Control ID	SIM908_Hardware Design_V1.05

General Notes

SIMCom offers this information as a service to its customers, to support application and engineering efforts that use the products designed by SIMCom. The information provided is based upon requirements specifically provided to SIMCom by the customers. SIMCom has not undertaken any independent search for additional relevant information, including any information that may be in the customer's possession. Furthermore, system validation of this product designed by SIMCom within a larger electronic system remains the responsibility of the customer or the customer's system integrator. All specifications supplied herein are subject to change.

Copyright

This document contains proprietary technical information which is the property of SIMCom Limited, copying of this document and giving it to others and the using or communication of the contents thereof, are forbidden without express authority. Offenders are liable to the payment of damages. All rights reserved in the event of grant of a patent or the registration of a utility model or design. All specification supplied herein are subject to change without notice at any time.

Copyright © Shanghai SIMCom Wireless Solutions Ltd. 2011

Contents

Contents	3
Version History	7
1 Introduction	8
2 SIM908 Overview	8
2.1 SIM908 Key Features.....	8
2.2 Operating Modes.....	11
2.3 SIM908 Functional Diagram.....	12
3 Package Information	13
3.1 Pin out Diagram.....	13
3.2 Pin Description.....	14
3.3 Package Dimensions.....	16
3.4 Mechanical Dimensions of the RF Connector.....	17
4 GSM Application Interface	18
4.1 Power Supply.....	18
4.1.1 Minimizing Voltage Drop of VBAT.....	19
4.1.2 Monitoring Power Supply.....	19
4.2 Power on/down Scenarios.....	19
4.2.1 Power on SIM908.....	19
4.2.2 Power down SIM908.....	21
4.2.3 Restart SIM908 by PWRKEY Pin.....	22
4.3 Power Saving Mode.....	23
4.3.1 Minimum Functionality Mode.....	23
4.3.2 Sleep Mode 1 (AT+CSCLK=1).....	23
4.3.3 Wake Up SIM908 from Sleep Mode 1 (AT+CSCLK=1).....	23
4.3.4 Sleep Mode 2 (AT+CSCLK=2).....	24
4.3.5 Wake Up SIM908 from Sleep Mode 2 (AT+CSCLK=2).....	24
4.4 Charging Interface.....	24
4.4.1 Battery Pack Characteristics.....	24
4.4.2 Recommended Battery Pack.....	25
4.4.3 Implemented Charging Technique.....	25
4.4.4 Operating Modes during Charging.....	26
4.4.5 Charger Requirements.....	27
4.5 RTC Backup.....	27
4.6 Serial Interfaces.....	28
4.6.1 Function of Serial Port and Debug Port.....	29
4.6.2 Software Upgrade and Debug.....	30
4.7 Audio Interfaces.....	30
4.7.1 Speaker Interface Configuration.....	31
4.7.2 Microphone Interfaces Configuration.....	31
4.7.3 Earphone Interface Configuration.....	32
4.7.4 Audio Electronic Characteristics.....	32
4.8 SIM Card Interface.....	33

4.8.1	SIM Card Application	33
4.8.2	Design Considerations for SIM Card Holder	34
4.9	LCD Display/SPI Interface	35
4.10	Keypad Interface	36
4.11	ADC	36
4.12	RI Behaviors	37
4.13	Network Status Indication	38
4.14	General Purpose Input/Output (GPIO)	38
4.15	PWM	39
4.16	I ² C Bus	39
4.17	GSM Antenna Interface	39
5	GPS Application Interface	41
5.1	GPS Operating Modes	41
5.2	GPS Power on/down Scenarios	42
5.2.1	Power on GPS engine	42
5.2.2	Power down GPS engine	42
5.3	GPS-VANT-OUT and GPS-VANT-IN	42
5.4	GPS Antenna Interface	42
5.4.1	GPS Antenna Interface	42
5.4.2	GPS Antenna Choice Consideration	43
6	Electrical, Reliability and Radio Characteristics	44
6.1	Absolute Maximum Ratings	44
6.2	Recommended Operating Conditions	44
6.3	Digital Interface Characteristics	45
6.4	SIM Card Interface Characteristics	45
6.5	VDD_EXT Characteristics	45
6.6	SIM_VDD Characteristics	45
6.7	VRTC Characteristics	46
6.8	Current Consumption (VBAT = 3.8V, GPS engine is powered down)	46
6.9	Electro-Static Discharge	47
6.10	Radio Characteristics	47
6.10.1	Module RF Output Power	47
6.10.2	Module RF Receive Sensitivity	49
6.10.3	Module Operating Frequencies	49
7	Manufacturing	50
7.1	Top View of SIM908	50
7.2	Typical Solder Reflow Profile	50
7.3	Moisture Sensitivity Level (MSL)	50
	Appendix	51
A.	Related Documents	51
B.	Terms and Abbreviations	52
C.	Safety Caution	53

Table Index

TABLE 1: SIM908 GSM/GPRS ENGINE KEY FEATURES	8
TABLE 2: GPS ENGINE PERFORMANCE	10
TABLE 3: CODING SCHEMES AND MAXIMUM NET DATA RATES OVER AIR INTERFACE	10
TABLE 4: OVERVIEW OF OPERATING MODES	11
TABLE 5: PIN DESCRIPTION	14
TABLE 6: THE CURRENT CONSUMPTION OF MINIMUM FUNCTIONALITY MODE	23
TABLE 7: SPECIFICATION OF RECOMMENDED BATTERY PACK	25
TABLE 8: CHARGE OPERATING MODES	26
TABLE 9: AT COMMAND USUALLY USED IN CHARGE-ONLY MODE	27
TABLE 10: MICROPHONE INPUT CHARACTERISTICS	32
TABLE 11: AUDIO OUTPUT CHARACTERISTICS	32
TABLE 12: PIN DESCRIPTION (AMPHENOL SIM CARD HOLDER)	34
TABLE 13: PIN DESCRIPTION (MOLEX SIM CARD HOLDER)	35
TABLE 14: PIN DEFINITION OF THE KEYPAD INTERFACE	36
TABLE 15: ADC SPECIFICATION	36
TABLE 16: RI BEHAVIORS	37
TABLE 17: STATUS OF THE NETLIGHT PIN	38
TABLE 18: PIN DEFINITION OF THE GPIO INTERFACE	39
TABLE 19: AT COMMANDS FOR GPS FUNCTION	41
TABLE 20: ABSOLUTE MAXIMUM RATINGS	44
TABLE 21: RECOMMENDED OPERATING CONDITIONS	44
TABLE 22: DIGITAL INTERFACE CHARACTERISTICS	45
TABLE 23: SIM CARD INTERFACE CHARACTERISTICS	45
TABLE 24: VDD_EXT CHARACTERISTICS	45
TABLE 25: SIM_VDD CHARACTERISTICS	46
TABLE 26: VRTC CHARACTERISTICS	46
TABLE 27: GSM CURRENT CONSUMPTION	46
TABLE 28: THE ESD CHARACTERISTICS (TEMPERATURE: 25°C, HUMIDITY: 45 %)	47
TABLE 29: SIM908 GSM 900 AND GSM 850 CONDUCTED RF OUTPUT POWER	48
TABLE 30: SIM908 DCS 1800 AND PCS 1900 CONDUCTED RF OUTPUT POWER	48
TABLE 31: SIM908 CONDUCTED RF RECEIVE SENSITIVITY	49
TABLE 32: SIM908 OPERATING FREQUENCIES	49
TABLE 33: RELATED DOCUMENTS	51
TABLE 34: TERMS AND ABBREVIATIONS	52
TABLE 35: SAFETY CAUTION	53

Figure Index

FIGURE 1: SIM908 FUNCTIONAL DIAGRAM	12
FIGURE 2: SIM908 PIN OUT DIAGRAM (TOP VIEW)	13
FIGURE 3: DIMENSIONS OF SIM908 (UNIT: MM)	16
FIGURE 4: RECOMMENDED PCB FOOTPRINT OUTLINE (UNIT: MM)	16
FIGURE 5: U.FL-R-SMT (UNIT:MM).....	17
FIGURE 6: U.FL SERIES RF ADAPTER CABLE (UNIT:MM).....	17
FIGURE 7: REFERENCE CIRCUIT OF THE LDO POWER SUPPLY	18
FIGURE 8: REFERENCE CIRCUIT OF THE DC-DC POWER SUPPLY	18
FIGURE 9: VBAT VOLTAGE DROP DURING TRANSMIT BURST.....	19
FIGURE 10: THE MINIMAL VBAT VOLTAGE REQUIREMENT AT VBAT DROP	19
FIGURE 11: POWERED ON/DOWN MODULE USING TRANSISTOR.....	19
FIGURE 12: POWERED ON/DOWN MODULE USING BUTTON	20
FIGURE 13: TIMING OF POWER ON MODULE.....	20
FIGURE 14: TIMING OF POWER DOWN SIM908 BY PWRKEY	21
FIGURE 15: TIMING OF RESTART SIM908	22
FIGURE 16: SIM908 WITH BATTERY CHARGER AND PACK CONNECTION.....	24
FIGURE 17: RTC SUPPLY FROM CAPACITOR.....	27
FIGURE 18: RTC SUPPLY FROM NON-CHARGEABLE BATTERY	27
FIGURE 19: RTC SUPPLY FROM RECHARGEABLE BATTERY	28
FIGURE 20: SEIKO XH414H-IV01E CHARGE-DISCHARGE CHARACTERISTIC	28
FIGURE 21: CONNECTION OF THE SERIAL INTERFACES.....	28
FIGURE 22: CONNECTION OF RXD AND TXD ONLY.....	29
FIGURE 23: CONNECTION FOR SOFTWARE UPGRADING AND DEBUGGING	30
FIGURE 24: SPEAKER REFERENCE CIRCUIT	31
FIGURE 25: SPEAKER WITH AMPLIFIER REFERENCE CIRCUIT	31
FIGURE 26 : MICROPHONE REFERENCE CIRCUIT	31
FIGURE 27: EARPHONE REFERENCE CIRCUIT	32
FIGURE 28: REFERENCE CIRCUIT OF THE 8-PIN SIM CARD HOLDER.....	33
FIGURE 29: REFERENCE CIRCUIT OF THE 6-PIN SIM CARD HOLDER.....	33
FIGURE 30: AMPHENOL C707 10M006 5122 SIM CARD HOLDER	34
FIGURE 31: MOLEX 91228 SIM CARD HOLDER	35
FIGURE 32: REFERENCE CIRCUIT OF THE KEYPAD INTERFACE	36
FIGURE 33: RI BEHAVIOUR OF VOICE CALLING AS A RECEIVER.....	37
FIGURE 34: RI BEHAVIOUR OF DATA CALLING AS A RECEIVER.....	37
FIGURE 35: RI BEHAVIOUR OF URC OR RECEIVE SMS	37
FIGURE 36: RI BEHAVIOUR AS A CALLER	38
FIGURE 37: REFERENCE CIRCUIT OF NETLIGHT	38
FIGURE 38: THE RF INTERFACE OF MODULE.....	40
FIGURE 39: GSM ANTENNA MATCHING CIRCUIT	40
FIGURE 40: GPS ANTENNA MATCHING CIRCUIT	43
FIGURE 41: TOP VIEW OF SIM908 MODULE	50
FIGURE 42: TYPICAL SOLDER REFLOW PROFILE	50

Version History

Date	Version	Description of change	Author
2011-06-28	1.00	Origin	LiGang
2011-08-26	1.01	Correct the NC pins; Correct the name of table 19;	Ma Honggang
2011-08-29	1.02	Modify antenna design guide	Ye haibing
2011-09-02	1.03	Correct the figure 21	MA Honggang
2011-09-09	1.04	Add NC PIN53	MA Honggang
2011-09-22	1.05	Correct the pin44 name in figure 2	MA Honggang

SIMCOM CONFIDENTIAL FILE

1 Introduction

This document describes SIM908 hardware interface in great detail.

This document can help user to quickly understand SIM908 interface specifications, electrical and mechanical details. With the help of this document and other SIM908 application notes, user guide, users can use SIM908 to design various applications quickly.

2 SIM908 Overview

Designed for global market, SIM908 is integrated with a high performance GSM/GPRS engine and a GPS engine. The GSM/GPRS engine is a quad-band GSM/GPRS module that works on frequencies GSM 850MHz, EGSM 900MHz, DCS 1800MHz and PCS 1900MHz. SIM908 features GPRS multi-slot class 10/ class 8 (optional) and supports the GPRS coding schemes CS-1, CS-2, CS-3 and CS-4. The GPS solution offers best- in-class acquisition and tracing sensitivity, Time-To-First-Fix (TTFF) and accuracy.

With a tiny configuration of 30*30*3.2mm, SIM908 can meet almost all the space requirements in user applications, such as M2M, smart phone, PDA, tracker and other mobile devices.

SIM908 has 80 SMT pads, and provides all hardware interfaces between the module and customers' boards.

- Serial port and debug port can help user easily develop user's applications.
- GPS Serial port.
- Two audio channels include two audio inputs and two audio outputs. These can be easily configured by AT command.
- Charging interface.
- Programmable general purpose input and output.
- The keypad and SPI display interfaces will give users the flexibility to develop customized applications.
- RF pad and connector interface.

SIM908 is designed with power saving technique so that the current consumption is as low as 1.0mA in sleep mode (GPS engine is powered down).

SIM908 integrates TCP/IP protocol and extended TCP/IP AT commands which are very useful for data transfer applications. For details about TCP/IP applications, please refer to *document [2]*.

2.1 SIM908 Key Features

Table 1: SIM908 GSM/GPRS engine key features

Feature	Implementation
Power supply	3.2V ~ 4.8V
Power saving	Typical power consumption in sleep mode is 1.0mA (BS-PA-MFRMS=9, GPS engine is powered down)
Charging	Supports charging control for Li-Ion battery
Frequency bands	● SIM908 Quad-band: GSM 850, EGSM 900, DCS 1800, PCS 1900. SIM908

	<p>can search the 4 frequency bands automatically. The frequency bands also can be set by AT command “AT+CBAND”. For details, please refer to <i>document [1]</i>.</p> <ul style="list-style-type: none"> ● Compliant to GSM Phase 2/2+
Transmitting power	<ul style="list-style-type: none"> ● Class 4 (2W) at GSM 850 and EGSM 900 ● Class 1 (1W) at DCS 1800 and PCS 1900
GPRS connectivity	<ul style="list-style-type: none"> ● GPRS multi-slot class 10 (default) ● GPRS multi-slot class 8 (option)
Temperature range	<ul style="list-style-type: none"> ● Normal operation: -30°C ~ +80°C ● Restricted operation: -40°C ~ -30°C and +80 °C ~ +85°C* ● Storage temperature -45°C ~ +90°C
Data GPRS	<ul style="list-style-type: none"> ● GPRS data downlink transfer: max. 85.6 kbps ● GPRS data uplink transfer: max. 42.8 kbps ● Coding scheme: CS-1, CS-2, CS-3 and CS-4 ● Integrate the TCP/IP protocol. ● Support Packet Broadcast Control Channel (PBCCH)
CSD	<ul style="list-style-type: none"> ● Support CSD transmission
USSD	<ul style="list-style-type: none"> ● Unstructured Supplementary Services Data (USSD) support
SMS	<ul style="list-style-type: none"> ● MT, MO, CB, Text and PDU mode ● SMS storage: SIM card
FAX	Group 3 Class 1
SIM interface	Support SIM card: 1.8V, 3V
External antenna	Antenna pad
Audio features	<p>Speech codec modes:</p> <ul style="list-style-type: none"> ● Half Rate (ETS 06.20) ● Full Rate (ETS 06.10) ● Enhanced Full Rate (ETS 06.50 / 06.60 / 06.80) ● Adaptive multi rate (AMR) ● Echo Cancellation ● Noise Suppression
Serial port and debug port	<p>Serial port:</p> <ul style="list-style-type: none"> ● Full modem interface with status and control lines, unbalanced, asynchronous. ● 1200bps to 115200bps. ● Can be used for AT commands or data stream. ● Support RTS/CTS hardware handshake and software ON/OFF flow control. ● Multiplex ability according to GSM 07.10 Multiplexer Protocol. ● Autobauding supports baud rate from 1200 bps to 57600bps. <p>Debug port:</p> <ul style="list-style-type: none"> ● Null modem interface GPS/DBG_TXD and GPS/DBG_RXD. ● Can be used for debugging and upgrading firmware.
Phonebook management	Support phonebook types: SM, FD, LD, RC, ON, MC.
SIM application toolkit	GSM 11.14 Release 99
Real time clock	Support RTC
Physical characteristics	<p>Size: 30*30*3.2mm</p> <p>Weight: 5.2g</p>

Firmware upgrade	Firmware upgradeable by debug port.
------------------	-------------------------------------

*SIM908 does work at this temperature, but some radio frequency characteristics may deviate from the GSM specification.

Table 2: GPS engine Performance

Parameter	Description	Performance			
		Min	Typ	Max	Unit
Horizontal Position Accuracy ^(a)	Autonomous		2.5		m
Velocity Accuracy ^(b)	Speed	-	0.01	-	m/s
	Heading	-	0.01	-	°
Time To First Fix ^(c)	Hot start	-	1	-	s
	Cold start	-	30	-	s
Sensitivity	Autonomous acquisition		-143		dBm
	Tracking		-160		dBm
Receiver	Channels		42		
	Update rate		1		Hz
	Altitude			18288	km
	Velocity			1850	km/h
	Tracking L1, CA Code				
	Protocol support NMEA,OSP				
Power consumption ^(d)	Continuous tracking		76		mA
	acquisition		77		
	Power down current		0.03		uA

Table 3: Coding schemes and maximum net data rates over air interface

Coding scheme	1 timeslot	2 timeslot	4 timeslot
CS-1	9.05kbps	18.1kbps	36.2kbps
CS-2	13.4kbps	26.8kbps	53.6kbps
CS-3	15.6kbps	31.2kbps	62.4kbps
CS-4	21.4kbps	42.8kbps	85.6kbps

2.2 Operating Modes

The table below summarizes the various operating modes of SIM908.

Table 4: Overview of operating modes

Mode	Function
Normal operation	GSM/GPRS SLEEP Module will automatically go into sleep mode if the conditions of sleep mode are enabling and there is no on air and no hardware interrupt (such as GPIO interrupt or data on serial port). In this case, the current consumption of module will reduce to the minimal level. In sleep mode, the module can still receive paging message and SMS.
	GSM IDLE Software is active. Module registered to the GSM network, and the module is ready to communicate.
	GSM TALK Connection between two subscribers is in progress. In this case, the power consumption depends on network settings such as DTX off/on, FR/EFR/HR, hopping sequences, antenna.
	GPRS STANDBY Module is ready for GPRS data transfer, but no data is currently sent or received. In this case, power consumption depends on network settings and GPRS configuration.
	GPRS DATA There is GPRS data transfer (PPP or TCP or UDP) in progress. In this case, power consumption is related with network settings (e.g. power control level); uplink/downlink data rates and GPRS configuration (e.g. used multi-slot settings).
Power down	Normal power down by sending the AT command “AT+CPOWD=1” or using the PWRKEY. The power management unit shuts down the power supply for the baseband part of the module, and only the power supply for the RTC is remained. Software is not active. The serial port is not accessible. Power supply (connected to VBAT) remains applied.
Minimum functionality mode	AT command “AT+CFUN” can be used to set the module to a minimum functionality mode without removing the power supply. In this mode, the RF part of the module will not work or the SIM card will not be accessible, or both RF part and SIM card will be closed, and the serial port is still accessible. The power consumption in this mode is lower than normal mode.
Charge-only mode	The module will enter Charge-only mode automatically when a charger and battery are connected to a switched-off SIM908. In this mode, the module does not search for network and has limited access to available AT commands available. The module can also enter Charge-only mode from Charge mode during normal operation by normally powered down the module.
Charge mode during normal operation	The module will automatically go to this mode when a charger is connected to a Normal operation mode module when battery voltage is not lower than 3.2V. Normal operation mode includes: SLEEP, IDLE, TALK, GPRS IDLE and GPRS DATA.

2.3 SIM908 Functional Diagram

The following figure shows a functional diagram of SIM908:

- The GSM baseband engine
- The GPS engine
- Flash
- The GSM radio frequency part
- The antenna interface
- The other interfaces

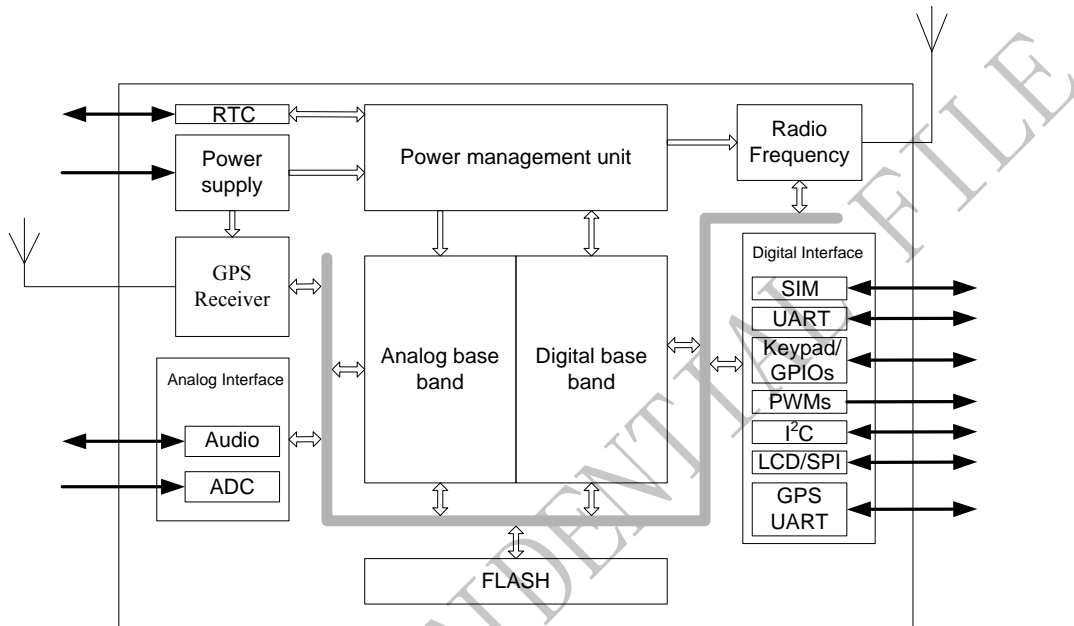

Figure 1: SIM908 functional diagram

3 Package Information

3.1 Pin out Diagram

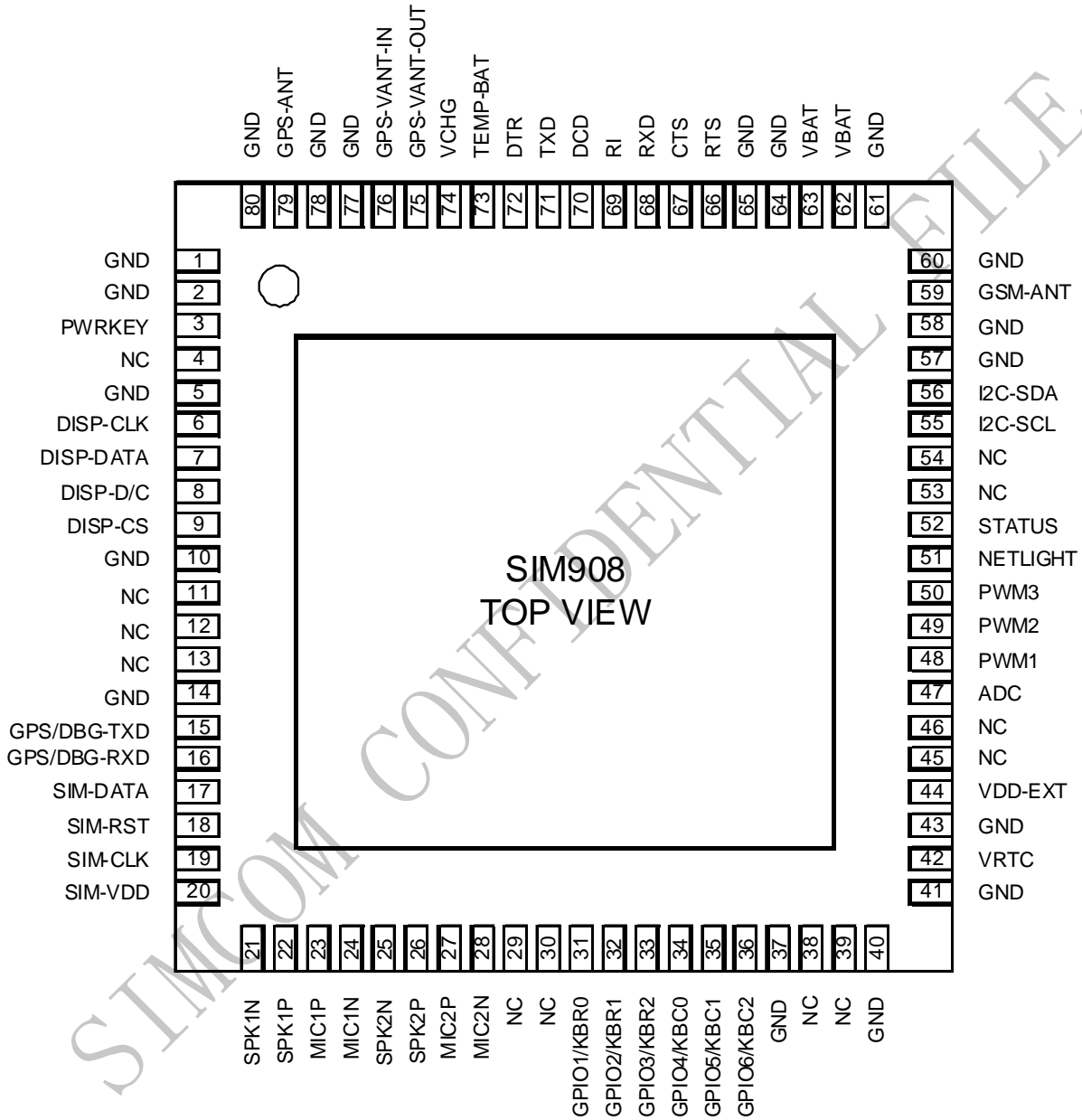

Figure 2: SIM908 pin out diagram (Top view)

3.2 Pin Description

Table 5: Pin description

Pin name	Pin number	I/O	Description	Comment
Power supply				
VBAT	62, 63	I	Power supply	3.2V ~ 4.8V
VRTC	42	I/O	Power supply for RTC	It is recommended to connect with a battery or a capacitor (e.g. 4.7uF).
VDD-EXT	44	O	2.8V output power supply	If it is unused, keep open.
GPS-VANT-OUT	75	O	2.8V output for GPS active antenna	If it is unused, keep open.
GPS-VANT-IN	76	I	GPS active antenna power supply	If it is unused, keep open.
GND	1, 2, 5, 10, 14, 37, 40, 41, 43, 57, 58, 60, 61, 64, 65, 77, 78, 80		Ground	
Charge interface				
VCHG	74	I	Charger input	
TEMP_BAT	73	I	Battery temperature sensor	
Power on/down				
PWRKEY	3	I	PWRKEY should be pulled low at least 1 second and then released to power on/down the module.	Pulled up internally.
Audio interfaces				
MIC1P	23	I	Differential audio input	If these pins are unused, keep open.
MIC1N	24			
SPK1P	22	O	Differential audio output	
SPK1N	21			
MIC2P	27	I	Differential audio input	
MIC2N	28			
SPK2N	25	O	Differential audio output	
SPK2P	26			
Status				
STATUS	52	O	Power on status	If these pins are unused, keep open.
NETLIGHT	51	O	Network status	
LCD interface				
DISP -CLK	6	O	Display interface	If these pins are unused, keep open.
DISP-DATA	7	I/O		
DISP -D/C	8	O		
DISP -CS	9	O		

I ² C interface				
I2C-SDA	56	O	I ² C serial bus data	If these pins are unused, keep open.
I2C-SCL	55	I/O	I ² C serial bus clock	
Keypad interface / GPIOs				
GPIO1/KBR0	31	I/O	GPIO1/keypad row 0	If these pins are unused, keep open.
GPIO2/KBR1	32		GPIO2/keypad row 1	
GPIO3/KBR2	33		GPIO3/keypad row 2	
GPIO4/KBC0	34		GPIO4/keypad column 0	
GPIO5/KBC1	35		GPIO5/keypad column 1	
GPIO6/KBC2	36		GPIO6/keypad column 3	
Serial port				
RXD	68	I	Receive data	If only TXD and RXD are used, it is suggested to pull down DTR, and others pins can be kept open.
TXD	71	O	Transmit data	
RTS	66	O	Request to send	
CTS	67	I	Clear to send	
DCD	70	O	Data carrier detect	
RI	69	O	Ring indicator	
DTR	72	I	Data terminal ready	
GPS/Debug interface				
GPS/DBG-TXD	15	O	For GPS NMEA information output , debugging and upgrading firmware	If these pins are unused, keep open.
GPS/DBG-RXD	16	I		
SIM interface				
SIM-VDD	20	O	Voltage supply for SIM card. Support 1.8V or 3V SIM card	All signals of SIM interface should be protected against ESD with a TVS diode array.
SIM-DATA	17	I/O	SIM data input/output	
SIM-CLK	19	O	SIM clock	
SIM-RST	18	O	SIM reset	
ADC				
ADC	47	I	Input voltage range: 0V ~ 2.8V	If it is unused, keep open.
Pulse width modulation(PWM)				
PWM1	48	O	PWM	If these pins are unused, keep open.
PWM2	49	O	PWM	
PWM3	50	O	PWM	
GSM/GPS RF interface				
GSM-ANT	59	I/O	GSM radio antenna connection	Impedence must be controlled to 50Ω.
GPS-ANT	79	I	GPS radio antenna connection	Impedence must be controlled to 50Ω.
Not connect				
NC	4,11,12,13,29,30,38,39,45,46,53,54	-		These pins should be kept open.

3.3 Package Dimensions

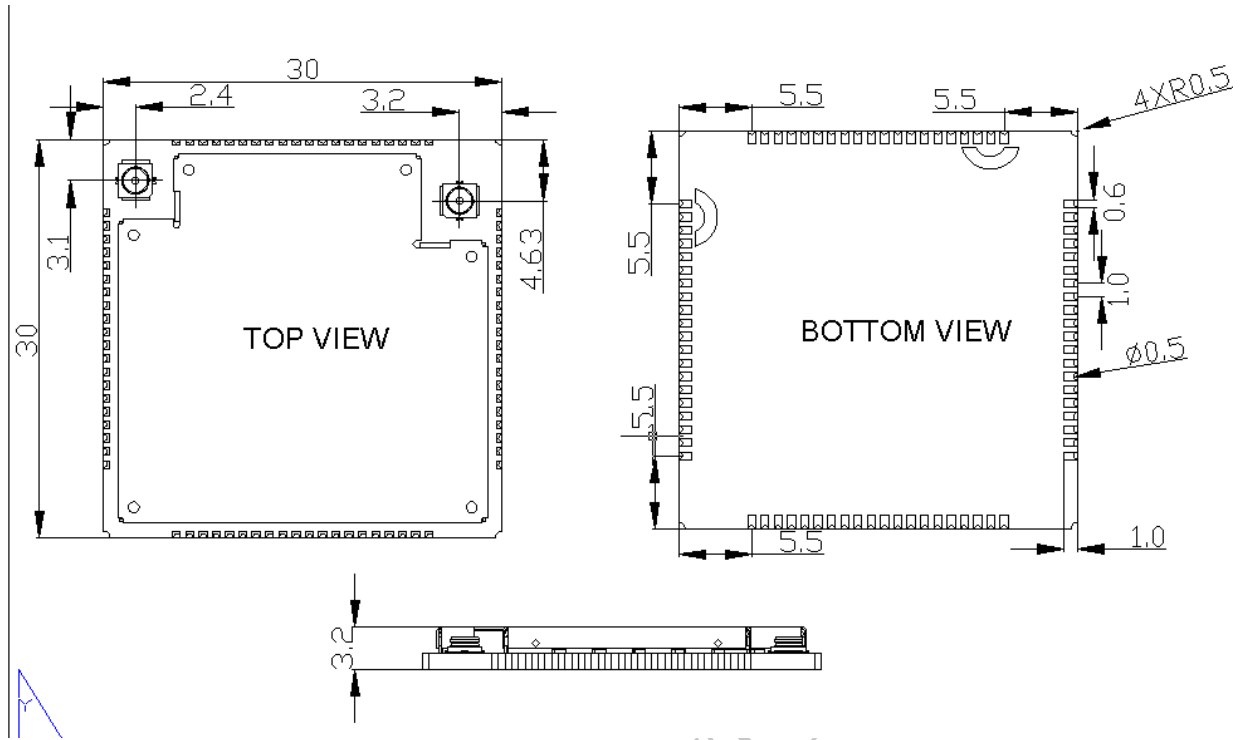

Figure 3: Dimensions of SIM908 (Unit: mm)

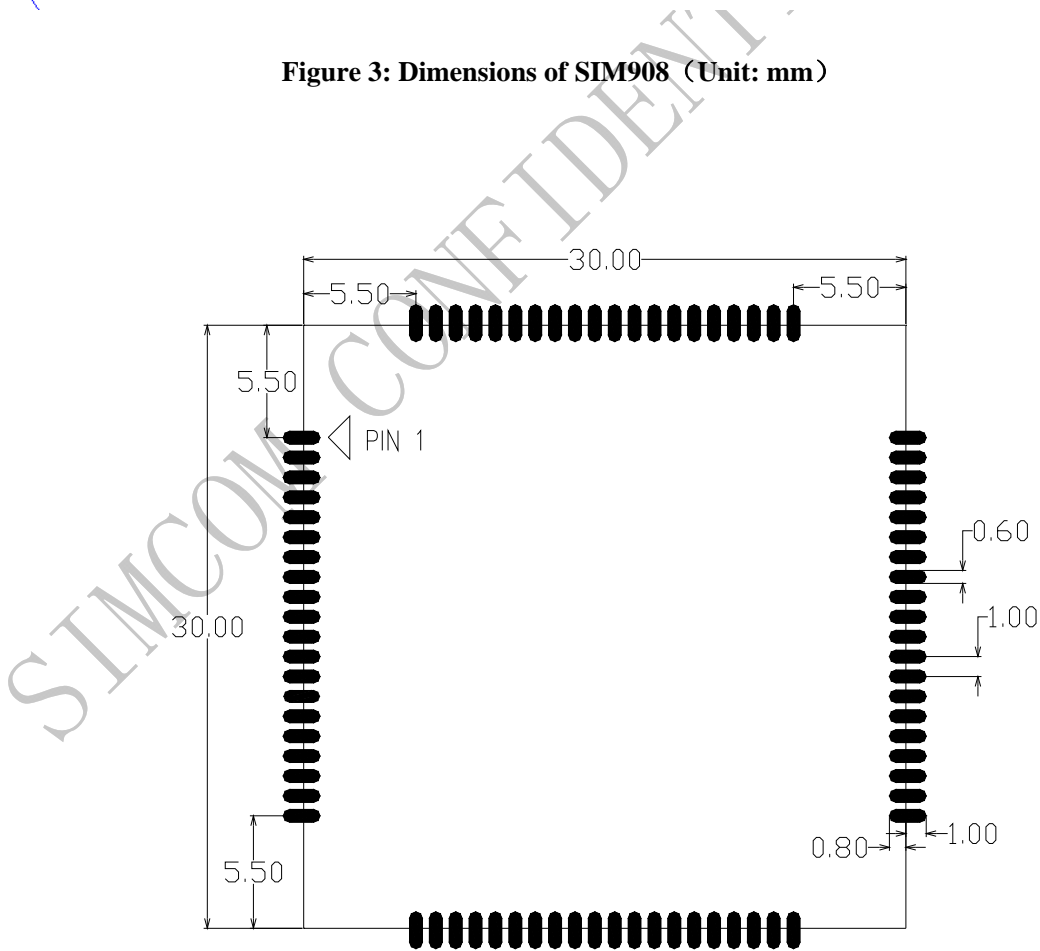

Figure 4: Recommended PCB footprint outline (Unit: mm)

3.4 Mechanical Dimensions of the RF Connector

The RF connector in the module side is an ultra small surface mount coaxial connectors (Part Number: U.FL-R-SMT, vended by HRS). It has high performance with wide frequency range, surface mountable and reflows solderable. Following figure are the related parameters. Certainly user can visit <http://www.hirose-connectors.com/> for more information.

To get good RF performance in user's design, SIMCom suggests user to use the matching RF adapter cable which is also supplied by HRS (Part Number: U.FL-LP(V)-040), the following figure is the dimensions of U.FL series RF adapter cable. User can contact SIMCom for more information.

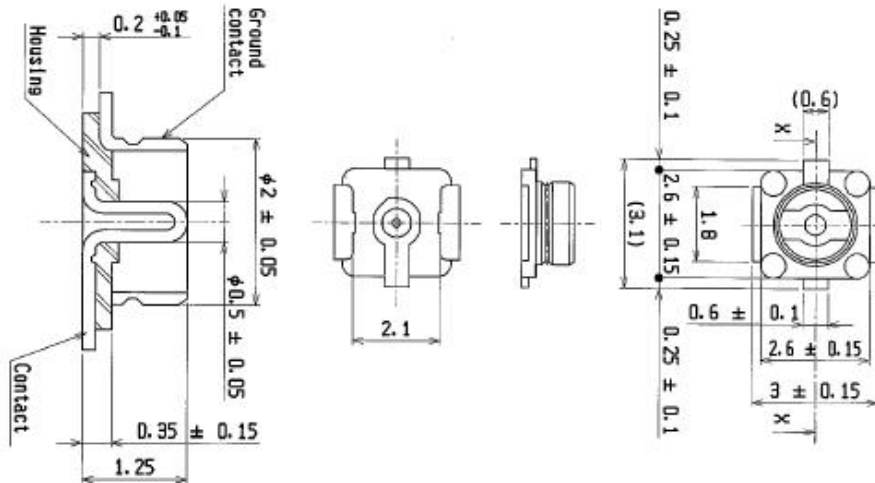

Figure 5: U.FL-R-SMT (Unit:mm)

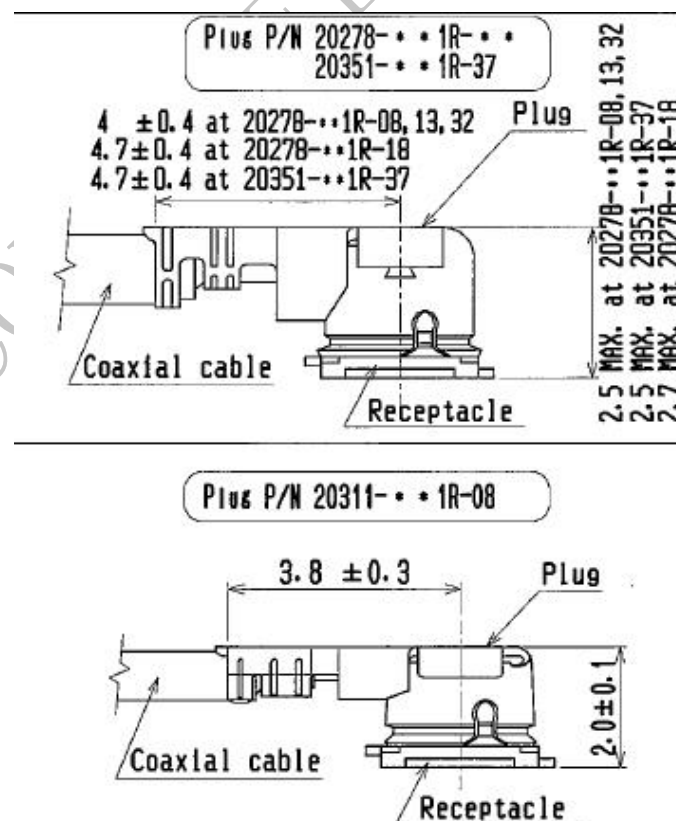

Figure 6: U.FL series RF adapter cable (Unit:mm)

4 GSM Application Interface

4.1 Power Supply

The power supply range of SIM908 is from 3.2V to 4.8V. The transmitting burst will cause voltage drop and the power supply must be able to provide sufficient current up to 2A. For the VBAT input, a bypass capacitor (low ESR) such as a 100 μ F is strongly recommended; this capacitor should be placed as close as possible to SIM908 VBAT pins. The following figure is the reference design of +5V input power supply. The designed output for the power supply is 4.1V, thus a linear regulator can be used.

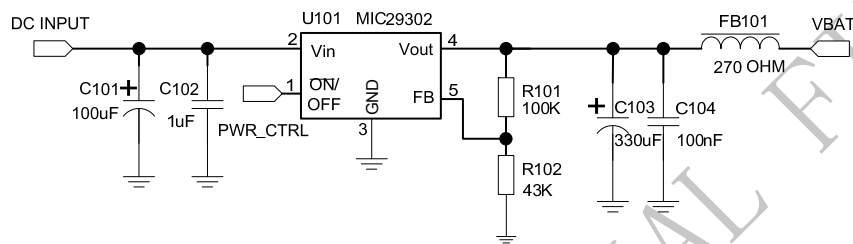

Figure 7: Reference circuit of the LDO power supply

If there is a high drop-out between the input and the desired output (VBAT), a DC-DC power supply will be preferable because of its better efficiency especially with the 2A peak current in burst mode of the module. The following figure is the reference circuit.

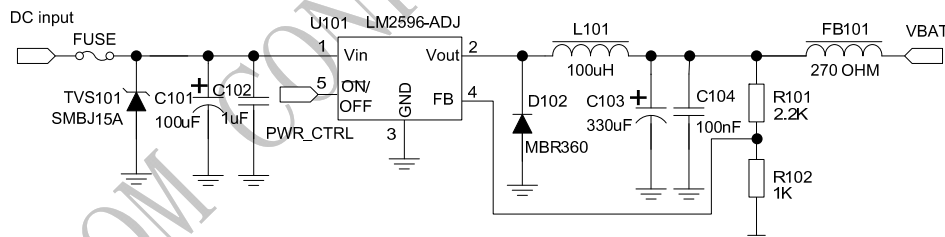

Figure 8: Reference circuit of the DC-DC power supply

The single 3.7V Li-ion cell battery can be connected to SIM908 VBAT pins directly. But the Ni-Cd or Ni-MH battery must be used carefully, since their maximum voltage can rise over the absolute maximum voltage of the module and damage it.

When battery is used, the total impedance between battery and VBAT pins should be less than 150m Ω . The following figure shows the VBAT voltage drop at the maximum power transmit phase, and the test condition is as following:

$$\text{VBAT}=4.0\text{V},$$

A VBAT bypass capacitor $C_A=100\mu\text{F}$ tantalum capacitor (ESR=0.7 Ω),

Another VBAT bypass capacitor $C_B=1\mu\text{F}$.

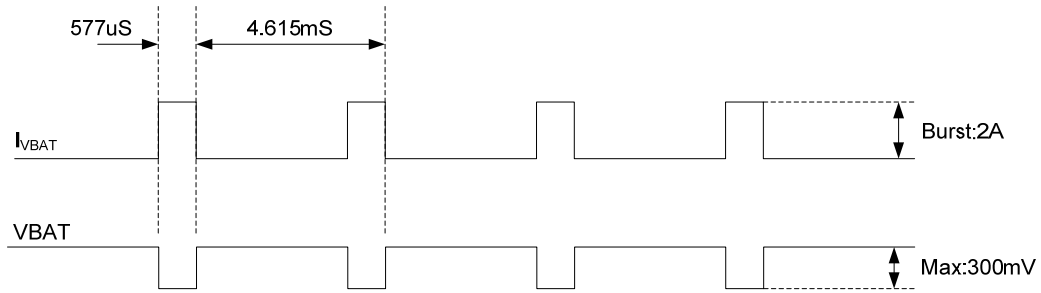

Figure 9: VBAT voltage drop during transmit burst

4.1.1 Minimizing Voltage Drop of VBAT

When designing the power supply in user’s application, pay special attention to power losses. Ensure that the input voltage never drops below 3.1V even when current consumption rises to 2A in the transmit burst. If the power voltage drops below 3.1V, the module may be shut down automatically. The PCB traces from the VBAT pins to the power supply must be wide enough (at least 60mil) to decrease voltage drops in the transmit burst. The power IC and the bypass capacitor should be placed to the module as close as possible.

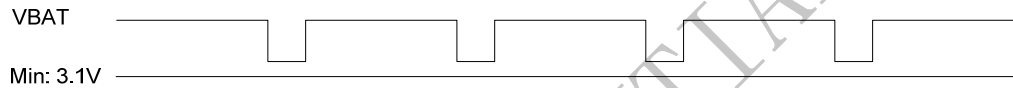

Figure 10: The minimal VBAT voltage requirement at VBAT drop

4.1.2 Monitoring Power Supply

The AT command “AT+CBC” can be used to monitor the VBAT voltage. For detail, please refer to *document [1]*.

4.2 Power on/down Scenarios

4.2.1 Power on SIM908

4.2.1.1 Turn on SIM900 Using the PWRKEY Pin (Power on)

User can power on SIM908 by pulling down the PWRKEY pin for at least 1 second and release. This pin is already pulled up to 3V in the module internal, so external pull up is not necessary. Reference circuit is shown as below.

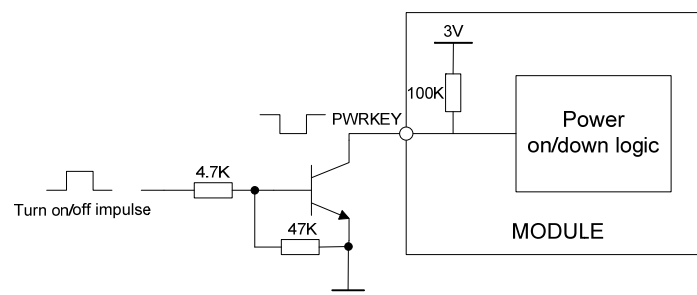

Figure 11: Powered on/down module using transistor

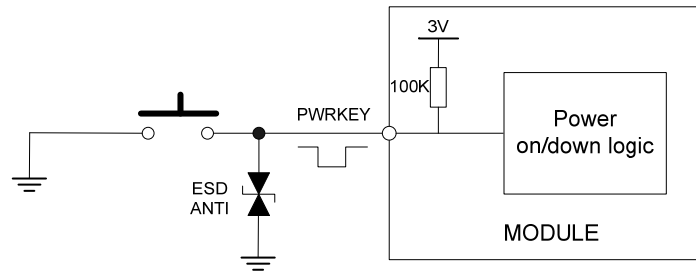

Figure 12: Powered on/down module using button

The power on scenarios is illustrated as following figure.

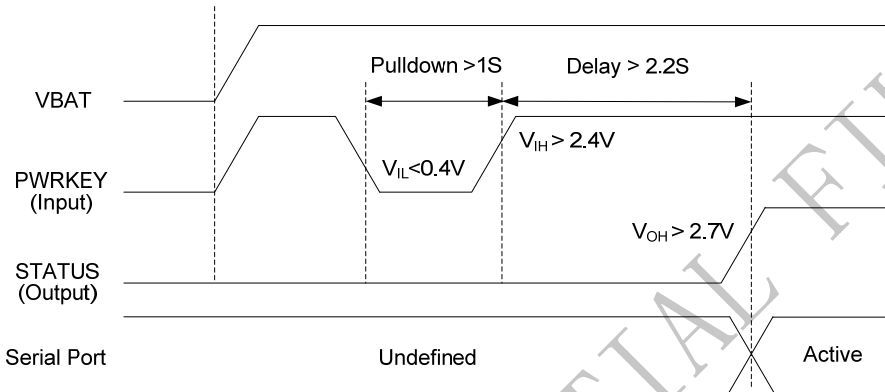

Figure 13: Timing of power on module

When power on procedure is completed, SIM908 will send following URC to indicate that the module is ready to operate at fixed baud rate.

RDY

This URC does not appear when autobauding function is active.

Note: User can use AT command “AT+IPR=x” to set a fixed baud rate and save the configuration to non-volatile flash memory. After the configuration is saved as fixed baud rate, the Code “RDY” should be received from the serial port every time when SIM908 is powered on. For details, please refer to the chapter “AT+IPR” in document [1].

4.2.1.2 Turn on the SIM908 using the VCHG Signal

The SIM908 will be automatically turned on when a charger is connected to the switched-off SIM908 of which VBAT pin voltage is greater than 3.2V. SIM908 will go into the Charge-only Mode. In this mode, the module does not register to the network, and has only a few AT commands available.

When module is powered on using the VCHG signal, SIM908 sends out result code as following when fixed baud rate set:

RDY

CHARGE-ONLY MODE

When user drives the PWRKEY of Charge-only mode SIM908 to a low level voltage for a period of time (please refer to *Figure 13 Timing of power on module*), the SIM908 will power up and go into Charge mode during normal operation. In this case, SIM908 sends out result code as following:

From CHARGE-ONLY MODE to NORMAL MODE

In Charge mode during normal operation, all operations and AT commands are available.

4.2.2 Power down SIM908

SIM908 will be powered down in the following situations:

- Normal power down procedure: power down SIM908 by the PWRKEY pin.
- Normal power down procedure: power down SIM908 by AT command “AT+CPOWD=1”.
- Abnormal power down: over-voltage or under-voltage automatic power down.
- Abnormal power down: over-temperature or under-temperature automatic power down.

4.2.2.1 Power down SIM908 by the PWRKEY Pin

User can power down SIM908 by pulling down the PWRKEY pin for at least 1 second and release. Please refer to the power on circuit. The power down scenario is illustrated in following figure.

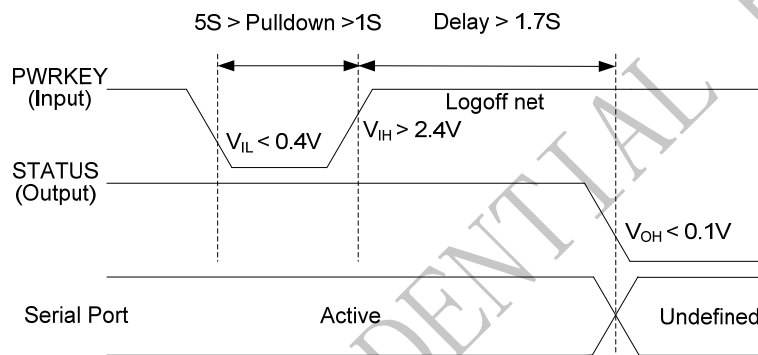

Figure 14: Timing of power down SIM908 by PWRKEY

This procedure makes the module log off from the network and allows the software to enter into a secure state to save data before completely shut down.

Before the completion of the power down procedure, the module will send URC:

NORMAL POWER DOWN

At this moment, AT commands can not be executed any more, and only the RTC is still active. Power down mode can also be indicated by STATUS pin, which is at low level at this time.

4.2.2.2 Power down SIM908 by AT Command

SIM908 can be powered down by AT command “AT+CPOWD=1”. This procedure makes the module log off from the network and allows the software to enter into a secure state to save data before completely shut down.

Before the completion of the power down procedure, the module will send URC:

NORMAL POWER DOWN

At this moment, AT commands can not be executed any more, and only the RTC is still active. Power down mode can also be indicated by STATUS pin, which is at low level at this time.

For detail about the AT command “AT+CPOWD”, please refer to *document [1]*

4.2.2.3 Over-voltage or Under-voltage Power down

The module software monitors the VBAT voltage constantly.

If the voltage $\leq 3.3V$, the following URC will be reported:

UNDER-VOLTAGE WARNING

If the voltage $\geq 4.7V$, the following URC will be reported:

OVER-VOLTAGE WARNING

If the voltage $< 3.2V$, the following URC will be reported, and the module will be automatically powered down.

UNDER-VOLTAGE POWER DOWN

If the voltage $> 4.8V$, the following URC will be reported, and the module will be automatically powered down.

OVER-VOLTAGE POWER DOWN

At this moment, AT commands can not be executed any more, and only the RTC is still active. Power down mode can also be indicated by STATUS pin, which is at low level at this time.

4.2.2.4 Over-temperature or Under-temperature Power down

The module will constantly monitor the temperature of the module,

If the temperature $> +80^{\circ}C$, the following URC will be reported:

+CMTE: 1

If the temperature $< -30^{\circ}C$, the following URC will be reported:

+CMTE:-1

If the temperature $> +85^{\circ}C$, the following URC will be reported, and the module will be automatically powered down.

+CMTE: 2

If the temperature $< -40^{\circ}C$, the following URC will be reported, and the module will be automatically powered down.

+CMTE:-2

At this moment, AT commands can not be executed any more, and only the RTC is still active. Power down mode can also be indicated by STATUS pin, which is at low level at this time.

The AT command “AT+CMTE” could be used to read the temperature when the module is running.

For details please refer to *document [1]*.

4.2.3 Restart SIM908 by PWRKEY Pin

When the module works normally, if the user wants to restart the module, follow the procedure below:

- 1) Power down the module.
- 2) Wait for at least 800mS after STATUS pin changed to low level.
- 3) Power on the module.

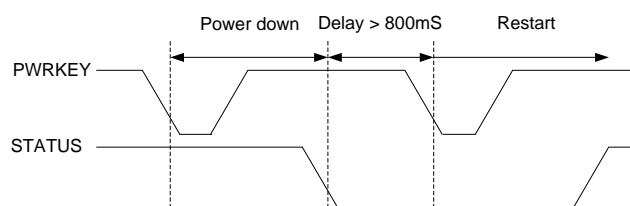

Figure 15: Timing of restart SIM908

4.3 Power Saving Mode

SIM908 have two sleep modes: sleep mode 1 is enabled by hardware pin DTR; sleep mode 2 is only enabled by serial port regardless of the DTR. In sleep mode, the current of module is very low. The AT command “AT+CFUN=<fun>” can be used to set SIM908 into minimum functionality. When SIM908 is in sleep mode and minimum functionality, the current of module is lowest.

4.3.1 Minimum Functionality Mode

There are three functionality modes, which could be set by the AT command “AT+CFUN=<fun>”. The command provides the choice of the functionality levels <fun>=0,1,4.

- AT+CFUN=0: minimum functionality.
- AT+CFUN=1: full functionality (default).
- AT+CFUN=4: flight mode (disable RF function).

Minimum functionality mode minimizes the current consumption to the lowest level. If SIM908 is set to minimum functionality by “AT+CFUN=0”, the RF function and SIM card function will be disabled. In this case, the serial port is still accessible, but all AT commands correlative with RF function and SIM card function will not be accessible.

For detailed information about the AT Command “AT+CFUN=<fun>”, please refer to *document [1]*.

Table 6: The current consumption of Minimum Functionality Mode

<fun>	Current consumption(uA) (sleep mode)
0	651
1	1500
4	715

4.3.2 Sleep Mode 1 (AT+CSCLK=1)

User can control SIM908 module to enter or exit the sleep mode 1 (AT+CSCLK=1) by DTR signal. When DTR is in high level and without interrupt (on air and hardware such as GPIO interrupt or data in serial port), SIM908 will enter sleep mode 1 automatically. In this mode, SIM908 can still receive paging or SMS from network but the serial port is not accessible.

Note: For SIM908, it requests to set AT command “AT+CSCLK=1” and ensure DTR at high level to enable the sleep mode 1; the default value is 0, which can not make the module to enter sleep mode. For more details please refer to document [1].

4.3.3 Wake Up SIM908 from Sleep Mode 1 (AT+CSCLK=1)

When SIM908 is in sleep mode 1 (AT+CSCLK=1), the following methods can wake up the module:

- Pull down DTR pin.
The serial port will be active after DTR pin is pulled to low level for about 50ms.
- Receive a voice or data call from network.

- Receive a SMS from network.

4.3.4 Sleep Mode 2 (AT+CSCLK=2)

In this mode, SIM908 will continuously monitor the serial port data signal. When there is no data transfer over 5 seconds on the RXD signal and there is no on air and hardware interrupts (such as GPIO interrupt), SIM908 will enter sleep mode 2 automatically. In this mode, SIM908 can still receive paging or SMS from network but the serial port is not accessible.

Note: For SIM908, It is requested to set AT command “AT+CSCLK=2” to enable the sleep mode 2; the default value is 0, which can not make the module to enter sleep mode. For more details please refer to document [1].

4.3.5 Wake Up SIM908 from Sleep Mode 2 (AT+CSCLK=2)

When SIM908 is in sleep mode 2 (AT+CSCLK=2), the following methods can wake up the module:

- Send data to SIM908 via main serial port. *
- Receive a voice or data call from network.
- Receive a SMS from network.

Note: The first byte of the user’s data will not be recognized.

4.4 Charging Interface

SIM908 has integrated a charging circuit inside the module for Li-Ion batteries charging control, which make it very convenient for user’s applications that support battery charging. A common connection is shown in the following figure:

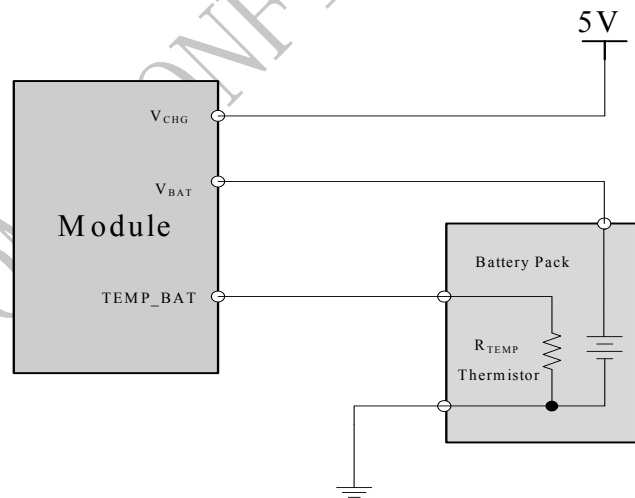

Figure 16: SIM908 with battery charger and pack connection

Battery temperature measurement is a customization function which is supported by the software in the module. In above figure, the R_{TEMP} is a NTC thermistor, and it is recommended to use MURATA NCP15XH103F03RC. Its impedance is 10Kohm at 25°C. Refer to the above figure for the reference circuit.

4.4.1 Battery Pack Characteristics

SIM908 has optimized the charging algorithm for the Li-Ion battery that meets the characteristics listed below.

- The maximum charging voltage of the Li-Ion battery pack is 4.2V and the recommended capacity is 1100mAh. The Battery packs with more than 1100 mAh capacity will take more time for charging.
- The battery pack should have a protection circuit to avoid overcharging, deep discharging and over-current, and the circuit should be insensitive to pulsed current.
- The internal resistance of the battery pack including protection circuit should be as low as possible. Its recommended value does not exceed 150mΩ.
- The battery pack must be protected from reverse pole connection.

On the SIM908, the build-in circuit of the power management chipset monitors the supply voltage constantly. Once the Under-voltage is detected, the SIM908 will be powered down automatically.

4.4.2 Recommended Battery Pack

Following is the specification of recommended battery pack:

Table 7: Specification of recommended battery pack

Items	Description
Battery type	Li-ion
Manufacturer	Jiade Energy Technology
Normal voltage	3.7V
Capacity	NORMAL 1100mAh
Charge Voltage	4.200±0.050V
Max Charge Current	1.0C
Charge Method	CC / CV (Constant Current / Constant Voltage)
Max Discharge Current	1.0C (for continuous discharging mode)
Discharge Cut-off Voltage	3.0V/ cell
Internal resistance	Initial≤130mΩ

4.4.3 Implemented Charging Technique

SIM908 has battery charging function. There are three pins related to the battery charging function: there are VCHG, VBAT and TEMP_BAT/ADC0 pins. The VCHG Pin is driven by an external voltage, system can use this Pin to detect a charger supply and provide most charging current through SIM908 module to battery when charging is in fast charge state. VBAT pin gives charging current to external battery from SIM908 module. TEMP_BAT Pin is for user to measure the battery temperature. Let this Pin open if battery temperature measurement is not user's design concern.

It is very simple to implement charging function, user just needs to connect the charger to the VCHG Pin and connect the battery to the VBAT Pin.

SIM908 battery charging happens after detecting charger supply and the presence of battery. If there is no charger supply or no battery present, charging function will not be enabled.

Normally, there are three main states in the whole charging procedure.

- DDLO charge (Pull-up mode) and UVLO charge (Pre-charge mode);
- Fast charge;

DDLO charge and UVLO charge:

DDLO is the state of battery when its voltage is under 1.5V. And UVLO means the battery voltage is less than 3.3V and more than 1.5V. The battery is not suitable for fast charging when its condition is DDLO or UVLO. The SIM908 provides a small constant current to the battery when the battery is between DDLO and UVLO. In DDLO charging state, SIM908 gives out 1mA current to the battery. And in UVLO charging state, SIM908 provides about less than 200mA current to the battery.

DDLO charging terminates when the battery voltage reaches 1.5V. UVLO charging terminates when the battery voltage is up to 3.3V. Both DDLO and UVLO charge are controlled by the SIM908 hardware only.

Fast charge:

If there is a charger supply and battery present and the battery is not in DDLO and UVLO, SIM908 will enter fast charge state. Fast charge is controlled by the software to make the current/voltage regulation. The charging scheme for the Li-Ion battery is constant current (about 550mA) first, followed by constant voltage charging once 4.2V is reached. Charging is stopped when the charging current at constant voltage has decreased down to the pre-set current.

4.4.4 Operating Modes during Charging

The battery can be charged during various operating mode. That means that charging can be in progress while SIM908 is in Normal mode (SLEEP, IDLE, TALK, GPRS IDLE or GPRS DATA mode). In this case the voltage supply should be sufficient. Here Charging in Normal mode is named as Charge mode.

If the charger is connected to the module’s VCHG Pin and the battery is connected to the VBAT Pin while SIM908 is in POWER DOWN mode, SIM908 will go into the Charge-only mode.

The following table gives the difference between Charge mode and Charge-only mode:

Table 8: Charge operating modes

	How to activate mode	Features
Charge Mode	Connect charger to module’s VCHG Pin and connect battery to VBAT Pin of module while SIM908 is in Normal operating mode, including: IDLE, TALK mode; SLEEP mode etc;	<ul style="list-style-type: none"> ● GSM remains operational and registers to GSM network while charging is in progress; ● The serial interfaces are available in IDLE, TALK mode, the AT command set can be used fully in this case; <p>In SLEEP mode, the serial interfaces are not available. Once the serial port is connected and there is data in transferring. SIM908 will exit the SLEEP mode.</p>
Charge-only Mode	Connect charger to module’s VCHG Pin while SIM908 is in POWER DOWN mode. IMPORTANT: Here Charge-only mode is charging when power is down, it means that not all software tasks are running.	<ul style="list-style-type: none"> ● Battery can be charged when GSM engine is not registered to GSM network; ● Only a few AT commands is available, as listed below.

Note: VBAT can not provide more than 5mA current while SIM908 module is during the DDLO charge state. In other words it is strongly recommended that VBAT should not be the main power supply in the application subsystem if SIM908 DDLO charging state occurs.

Table 9: AT command usually used in Charge-only mode

AT command	Function
AT+CCLK	Set data and time of RTC
AT+CPOWD	Power down
AT+CBC	Indicated charge state and voltage
AT+CFUN	Start or close the protocol Set AT command “AT+CFUN=1”, module can be transferred from Charge-only mode to Charging in normal mode. In Charge-only mode, the default value is 0.

4.4.5 Charger Requirements

Following is the requirements of charger for SIM908:

- Simple transformer power plug
- Output voltage: 5.0V~6V
- Minimum supply current: 750mA
- A 10V peak voltage is allowed for maximum 1ms when charging current is switched off.
- A 1.6A peak current is allowed for maximum 1ms when charging current is switched on.

4.5 RTC Backup

Current input for RTC when the VBAT is not supplied for the system. Current output for backup battery when the VBAT power supply is in present and the backup battery is in low voltage state. The RTC power supply of module can be provided by an external capacitor or a battery (non-chargeable or rechargeable) through the VRTC. The following figures show various reference circuits for RTC back up.

- **External capacitor backup**

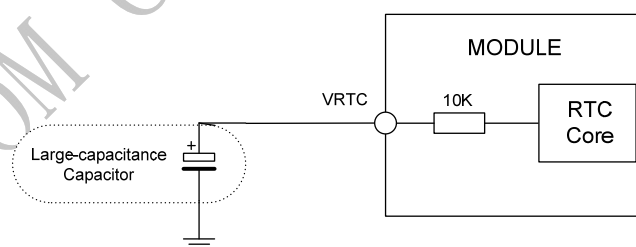
Figure 17: RTC supply from capacitor

- **Non-chargeable battery backup**

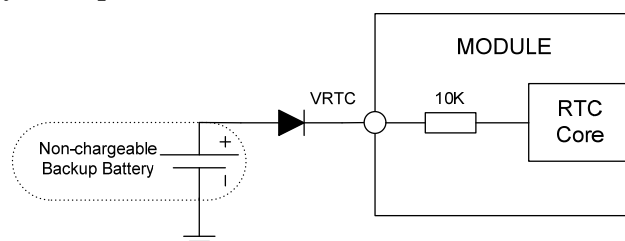
Figure 18: RTC supply from non-chargeable battery

● Rechargeable battery backup

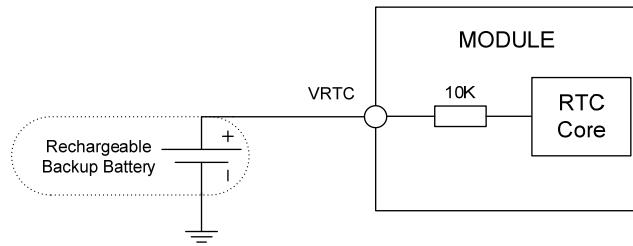

Figure 19: RTC supply from rechargeable battery

Coin-type rechargeable battery is recommended, such as XH414H-IV01E form Seiko can be used. Typical charge-discharge curves for this battery are shown in the following figure.

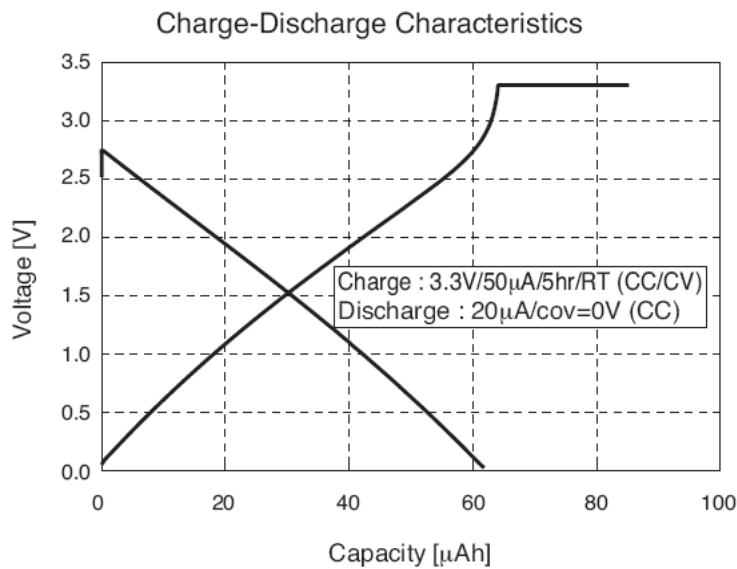

Figure 20: Seiko XH414H-IV01E charge-discharge characteristic

4.6 Serial Interfaces

SIM908 provides two unbalanced asynchronous serial ports. One is the serial port and the other is the debug port. The module is designed as a DCE (Data Communication Equipment). The following figure shows the connection between module and client (DTE).

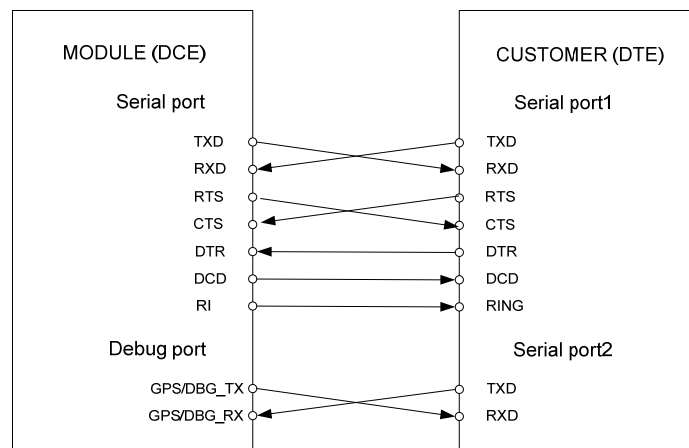

Figure 21: Connection of the serial interfaces

If only RXD and TXD are used in user's application, other serial pins should be kept open. Please refer to following figure.

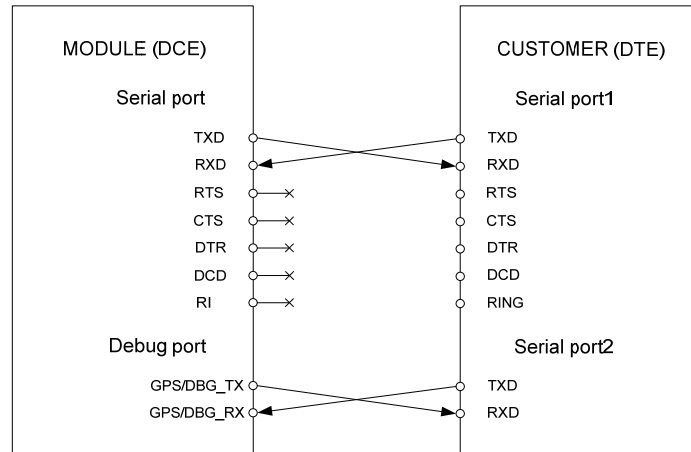

Figure 22: Connection of RXD and TXD only

4.6.1 Function of Serial Port and Debug Port

Serial port:

- Full modem device.
- Contains data lines TXD and RXD, hardware flow control lines RTS and CTS, status lines DTR, DCD and RI.
- Serial port can be used for CSD FAX, GPRS service and AT communication. It can also be used for multiplexing function. For details about multiplexing function, please refer to *document [3]*.
- Serial port supports the following baud rates:
1200, 2400, 4800, 9600, 19200, 38400, 57600 and 115200bps
- Autobauding only supports the following baud rates:
1200, 2400, 4800, 9600, 19200, 38400 and 57600bps
- The default setting is autobauding.

Autobauding allows SIM908 to automatically detect the baud rate of the host device. Pay more attention to the following requirements:

- **Synchronization between DTE and DCE:**
When DCE powers on with autobauding enabled, user must firstly send character "A" to synchronize the baud rate. It is recommended to send "AT" until DTE receives the "OK" response, which means DTE and DCE are correctly synchronized. For more information please refer to the AT command "AT+IPR".
- **Restrictions of autobauding operation:**
The DTE serial port must be set at 8 data bits, no parity and 1 stop bit.
The URC such as "RDY", "+CFUN: 1" and "+CPIN: READY" will not be reported.

Note: User can use AT command "AT+IPR=x" to set a fixed baud rate and the setting will be saved to non-volatile flash memory automatically. After the configuration is set as fixed baud rate, the URC such as "RDY", "+CFUN: 1" and "+CPIN: READY" will be reported when SIM908 is powered on.

Debug port:

- Used for debugging and upgrading firmware.
- Debug port supports the baud rate of 115200bps.

4.6.2 Software Upgrade and Debug

Refer to the following figure for debugging and upgrading software.

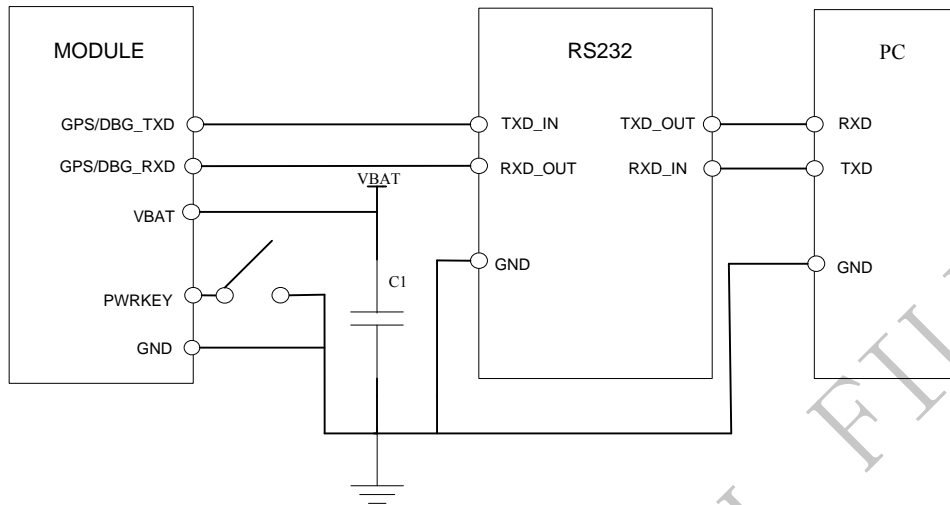

Figure 23: Connection for software upgrading and debugging

The serial port and the debug port support the CMOS level. If user connects the module to the computer, the level shifter should be added between the DCE and DTE.

For details about software upgrading, please refer to *document [4]*.

4.7 Audio Interfaces

SIM908 provides two analog inputs, MIC1P/1N and MIC2P/2N, which could be used for electret microphone. The module also provides two analog outputs, SPK1P/1N and SPK2P/2N. The output can directly drive 32Ω receiver.

AT command “AT+CMIC” is used to adjust the input gain level of microphone. AT command “AT+SIDET” is used to set the side-tone level. In addition, AT command “AT+CLVL” is used to adjust the output gain level. For more details, please refer to *document [1]* and *document [5]*.

In order to improve audio performance, the following reference circuits are recommended. The audio signals have to be layout according to differential signal layout rules as shown in following figures. If user needs to use an amplifier circuit for audio, National Semiconductor Company’s LM4890 is recommended.

4.7.1 Speaker Interface Configuration

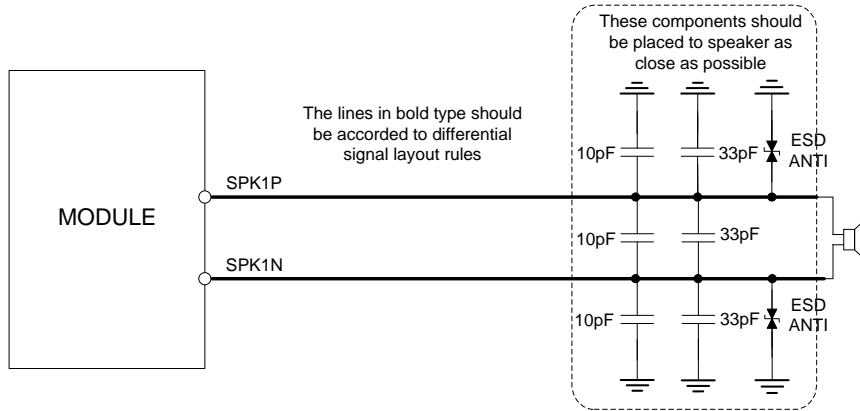

Figure 24: Speaker reference circuit

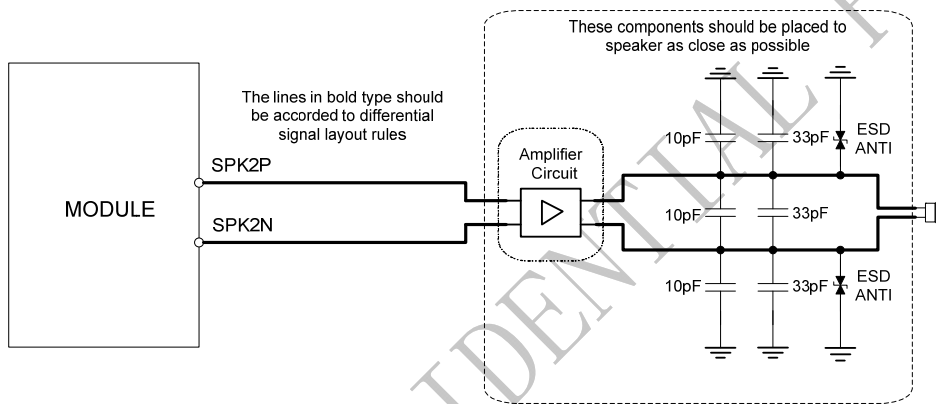

Figure 25: Speaker with amplifier reference circuit

4.7.2 Microphone Interfaces Configuration

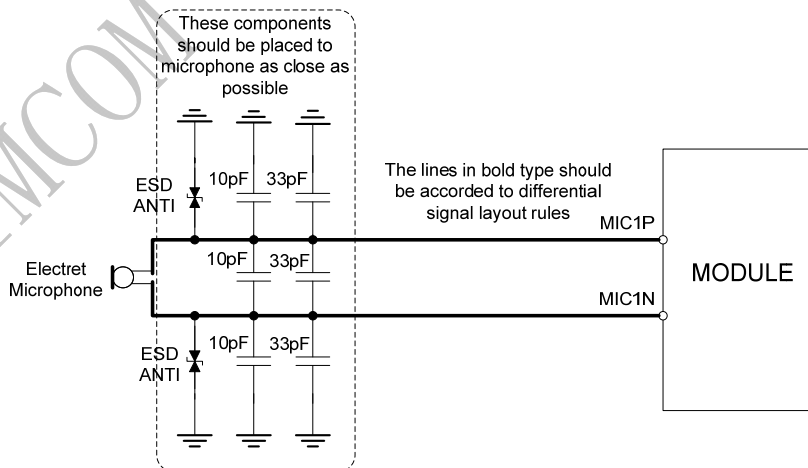

Figure 26 : Microphone reference circuit

Microphone input also could be used to LINE-IN input. For details, please refer to *document [6]*.

4.7.3 Earphone Interface Configuration

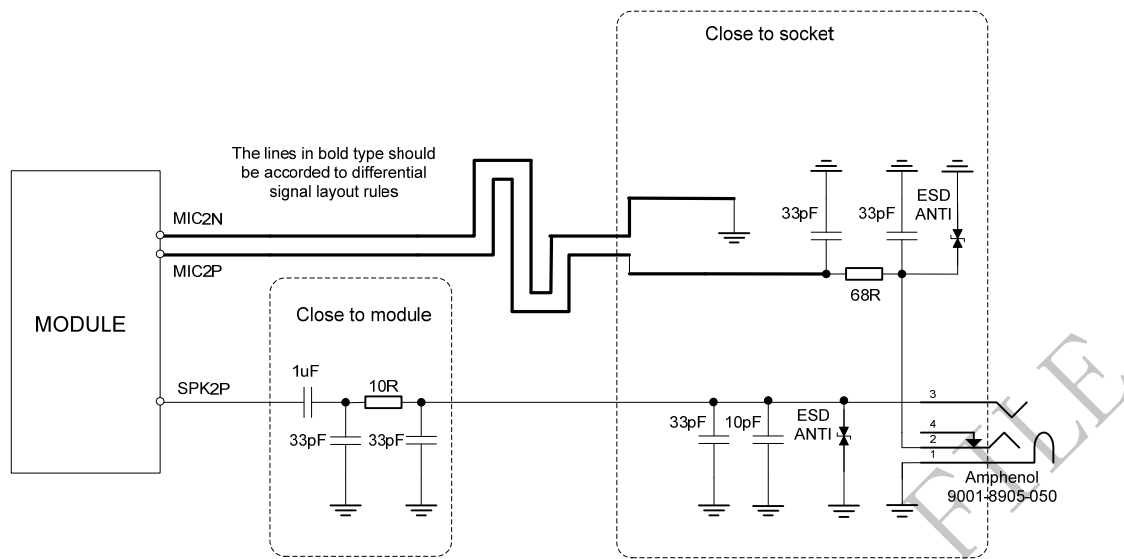

Figure 27: Earphone reference circuit

4.7.4 Audio Electronic Characteristics

Table 10: Microphone input characteristics

Parameter	Min	Typ	Max	Unit
Working Voltage	1.2	1.5	2.0	V
Working Current	200		500	uA
External Microphone Load Resistance	1.2	2.2		kΩ
Internal biasing DC Characteristics			2.5	V
Differential input voltage	THD <1% at F=1KHz; pre-amp gain = 20 dB; PGA gain = 14 dB	15.9		mVrms
	THD <5% at F=1KHz; pre-amp gain = 0 dB; PGA gain = 0 dB		740	mVrms

Table 11: Audio output characteristics

Parameter	Conditions	Min	Typ	Max	Unit
Normal Output (SPK)	RL=32Ω THD=0.1%	-	91	-	mW
	RL=32Ω THD=1%	-	96	-	mW
	Output swing voltage (single ended)			1.1	Vpp
	Output swing voltage (differential)			2.2	Vpp

4.8 SIM Card Interface

4.8.1 SIM Card Application

The SIM interface complies with the GSM Phase 1 specification and the new GSM Phase 2+ specification for FAST 64 kbps SIM card. Both 1.8V and 3.0V SIM card are supported. The SIM interface is powered from an internal regulator in the module.

It is recommended to use an ESD protection component such as ST (www.st.com) ESDA6V1W5 or ON SEMI (www.onsemi.com) SMF05C. The pull up resistor (15KΩ) on the SIM_DATA line is already added in the module internal. Note that the SIM peripheral circuit should be close to the SIM card socket. The reference circuit of the 8-pin SIM card holder is illustrated in the following figure.

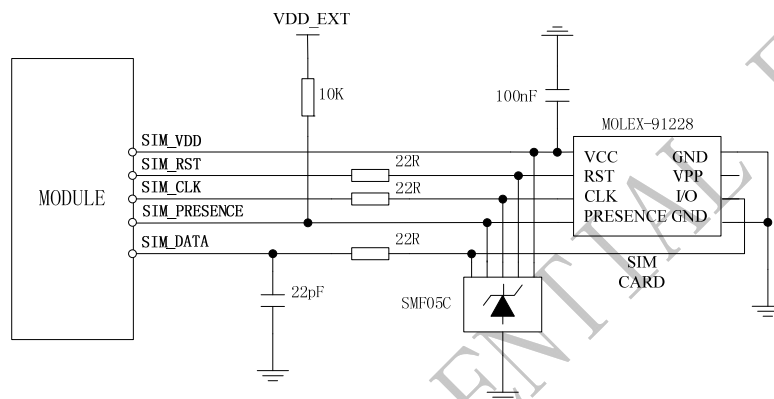

Figure 28: Reference circuit of the 8-pin SIM card holder

The SIM_PRESENCE pin is used for detection of the SIM card hot plug in. User can select the 8-pin SIM card holder to implement SIM card detection function. AT command “AT+CSDT” is used to enable or disable SIM card detection function. For details of this AT command, please refer to *document [1]*.

If the SIM card detection function is not used, user can keep the SIM_PRESENCE pin open. The reference circuit of 6-pin SIM card holder is illustrated in the following figure.

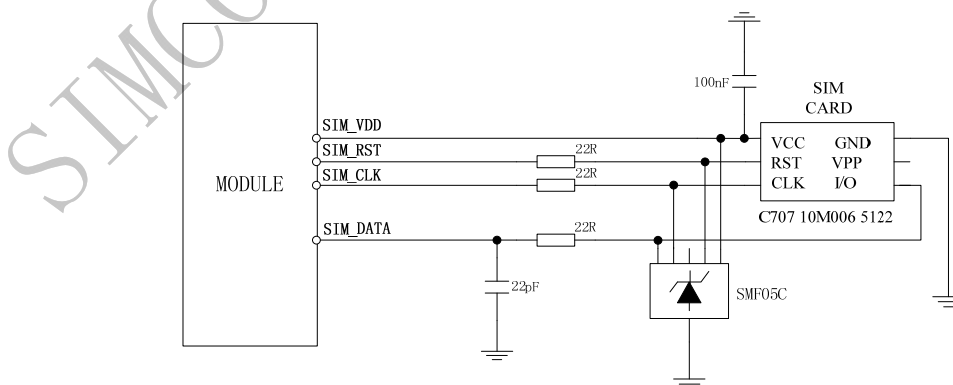

Figure 29: Reference circuit of the 6-pin SIM card holder

4.8.2 Design Considerations for SIM Card Holder

For 6-pin SIM card holder, SIMCom recommends to use Amphenol C707 10M006 5122 .User can visit <http://www.amphenol.com> for more information about the holder.

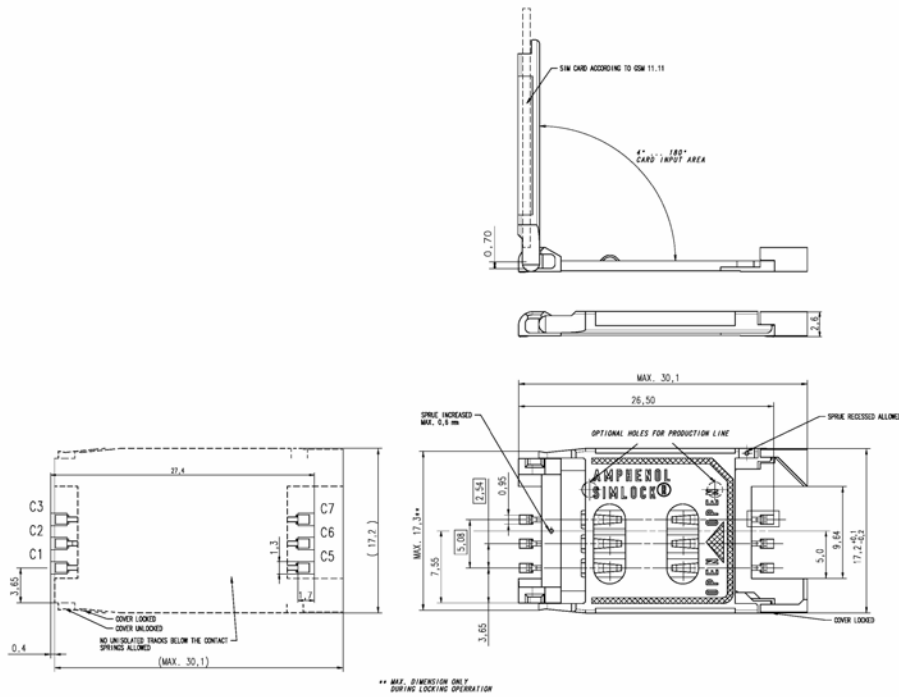

Figure 30: Amphenol C707 10M006 5122 SIM card holder

Table 12: Pin description (Amphenol SIM card holder)

Pin name	Signal	Description
C1	SIM-VDD	SIM card power supply
C2	SIM-RST	SIM card reset
C3	SIM-CLK	SIM card clock
C5	GND	Connect to GND
C6	VPP	Not connect
C7	SIM-DATA	SIM card data I/O

For 8 pins SIM card holder, SIMCom recommends to use Molex 91228. User can visit <http://www.molex.com> for more information about the holder.

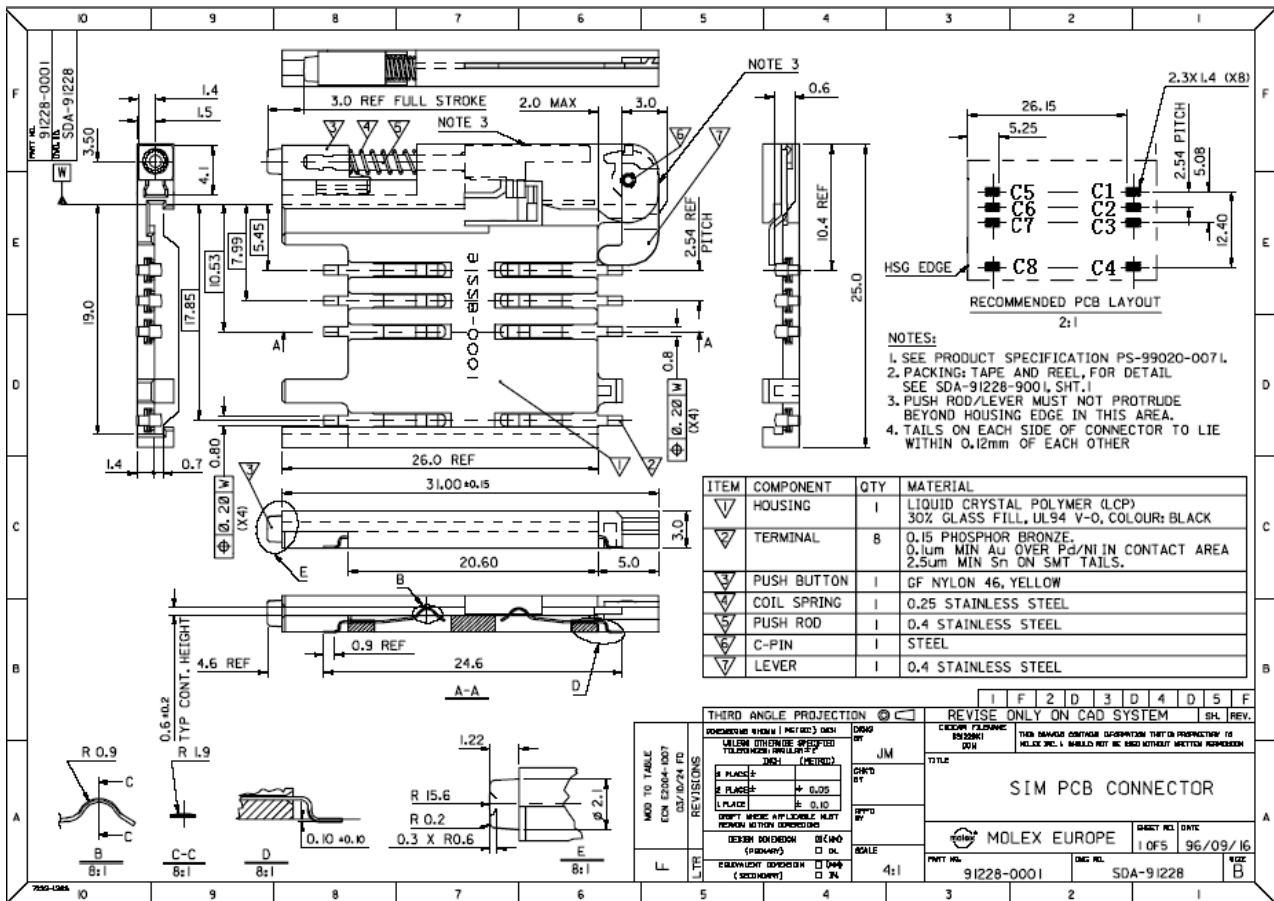

Figure 31: Molex 91228 SIM card holder

Table 13: Pin description (Molex SIM card holder)

Pin name	Signal	Description
C1	SIM-VDD	SIM card power supply
C2	SIM-RST	SIM card reset
C3	SIM-CLK	SIM card clock
C4	GND	Connect to GND
C5	GND	Connect to GND
C6	VPP	Not connect
C7	SIM-DATA	SIM card data I/O
C8	SIM-PRESENCE	Detect SIM card presence

4.9 LCD Display/SPI Interface

SIM908 provides a serial LCD display interface. It could also be used as SPI interface in the embedded AT application. For details about embedded AT application, please refer to *document [7]*.

Note: This function is not supported in the standard firmware. If user wants this function, the firmware must be customized. Please contact SIMCom for more details.

4.10 Keypad Interface

The keypad interface consists of 3 keypad column outputs and 3 keypad row inputs. The basic configuration is 3 keypad columns and 3 keypad rows, total 9 keys.

Table 14: Pin definition of the keypad interface

Pin name	Pin number	Default function	Second function	Default state
GPIO1/ KBR0	31	GPIO1	Keypad matrix	Output, Pull down
GPIO2/ KBR1	32	GPIO2		Output, Pull down
GPIO3/ KBR2	33	GPIO3		Output, Pull down
GPIO4/ KBC0	34	GPIO4		Output, Pull down
GPIO5/ KBC1	35	GPIO5		Output, Pull down
GPIO6/ KBC2	36	GPIO6		Output, Pull down

The keypad interface allows a direct external matrix connection. A typical recommended circuit of the keypad is shown in the following figure.

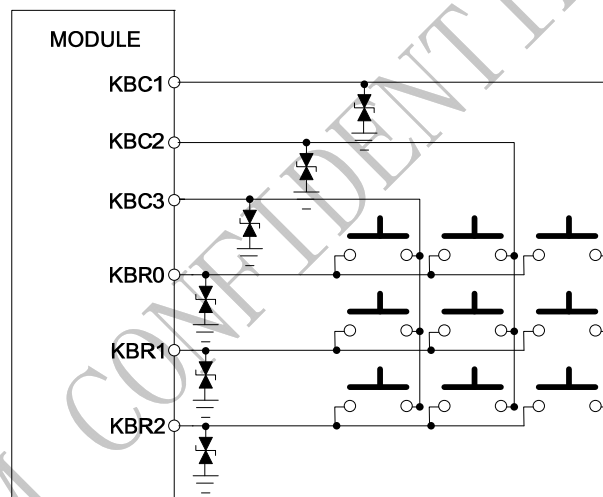

Figure 32: Reference circuit of the keypad interface

Note: This function is not supported in the standard firmware. If user wants this function, the firmware must be customized. Please contact SIMCom for more details.

4.11 ADC

SIM908 provides an auxiliary ADC, which can be used to measure the voltage. User can use AT command "AT+CADC" to read the voltage value. For details of this AT command, please refer to *document [1]*.

Table 15: ADC specification

Parameter	Min	Typ	Max	Unit
Voltage range	0	-	2.8	V
ADC Resolution	-	10	-	bits
Sampling rate	-	-	200K	Hz

4.12 RI Behaviors

Table 16: RI behaviors

State	RI response
Standby	High
Voice call	The pin is changed to low. When any of the following events occur, the pin will be changed to high: (1) Establish the call (2) Hang up the call
Data call	The pin is changed to low. When any of the following events occur, the pin will be changed to high: (1) Establish the call (2) Hang up the call
SMS	The pin is changed to low, and kept low for 120ms when a SMS is received. Then it is changed to high.
URC	The pin is changed to low, and kept low for 120ms when some URCs are reported. Then it is changed to high. For more details, please refer to <i>document [8]</i> .

The behavior of the RI pin is shown in the following figure when the module is used as a receiver.

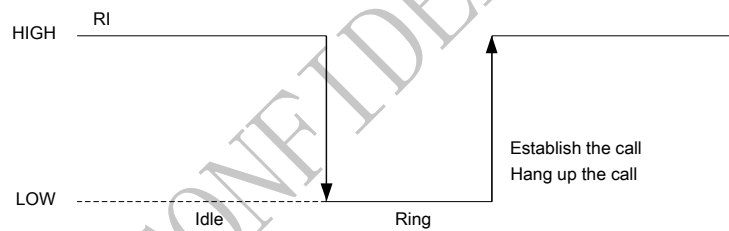

Figure 33: RI behaviour of voice calling as a receiver

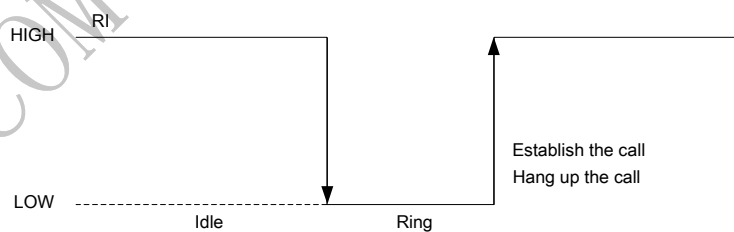

Figure 34: RI behaviour of data calling as a receiver

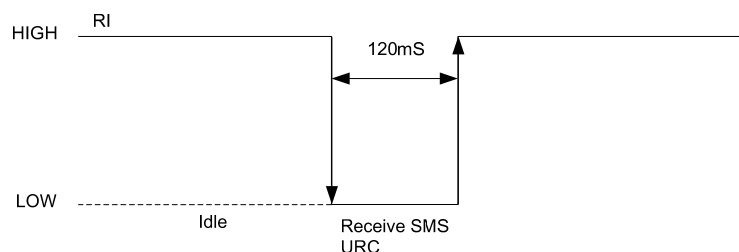

Figure 35: RI behaviour of URC or receive SMS

However, if the module is used as caller, the RI will remain high. Please refer to the following figure.

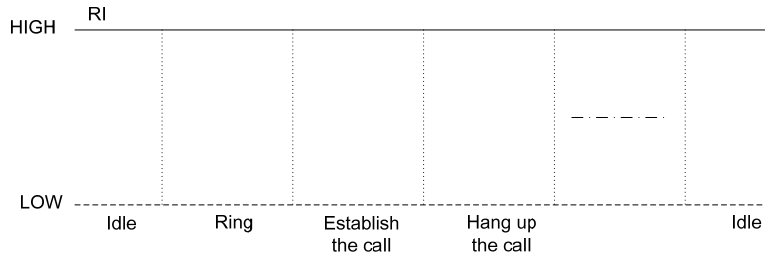

Figure 36: RI behaviour as a caller

4.13 Network Status Indication

The NETLIGHT pin can be used to drive a network status indication LED. The status of this pin is listed in following table:

Table 17: Status of the NETLIGHT pin

Status	SIM908 behavior
Off	SIM908 is not running
64ms On/ 800ms Off	SIM908 not registered the network
64ms On/ 3000ms Off	SIM908 registered to the network
64ms On/ 300ms Off	PPP GPRS communication is established

A reference circuit is recommended in the following figure:

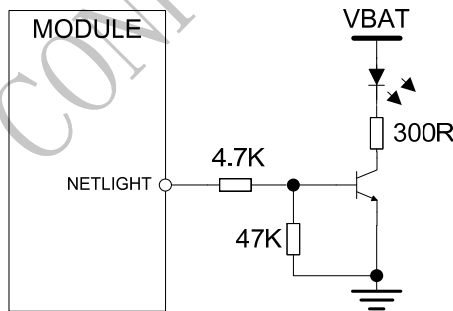

Figure 37: Reference circuit of NETLIGHT

4.14 General Purpose Input/Output (GPIO)

SIM908 provides up to 6 GPIO pins. The output voltage level of the GPIO can be set by the AT command “AT+SGPIO”. The input voltage level of the GPIO can also be read by the AT command “AT+SGPIO”. For more details, please refer to *document [1]*.

Table 18: Pin definition of the GPIO interface

Pin name	Pin number	Default function	Second function	Default state
GPIO1/ KBR0	31	GPIO1	KBR0	Output, pull down
GPIO2/ KBR1	32	GPIO2	KBR1	Output, pull down
GPIO3/ KBR2	33	GPIO3	KBR2	Output, pull down
GPIO4/ KBC0	34	GPIO4	KBC0	Output, pull down
GPIO5/ KBC1	35	GPIO5	KBC1	Output, pull down
GPIO6/ KBC2	36	GPIO6	KBC2	Output, pull down

4.15 PWM

SIM908 provides 3 PWMs which can be used to drive a vibrator, and a backlight LED for display or keyboard. Each PWM1 and PWM2 output frequency varies from 25.6KHz to 3.25MHz. Two 7-bit unsigned binary parameters are used for the output period and for the duty cycle. The PWM3 for the buzzer outputs a square wave at the desired tone frequency. The tone frequencies are programmable from 200 Hz to 5 kHz and can be re-programmed on-the-fly to generate monophonic audio ring tones or alert tones. The tone level can be adjusted over a 24 dB range in 4 dB steps, or it can be muted.

The AT command “AT + SPWM” is used to set the output period and duty cycle of the PWM. For details, please refer to *document [1]*.

4.16 I²C Bus

The SIM908 provides an I²C interface which is only used in the embedded AT application.

Note: This function is not supported in the standard firmware. If user wants this function, the firmware must be customized. Please contact SIMCom for more details.

4.17 GSM Antenna Interface

The RF interface has an impedance of 50Ω. To suit the physical design of individual applications, SIM908 offers alternatives

- Recommended approach: GSM RF connector
- GSM ANT pad.

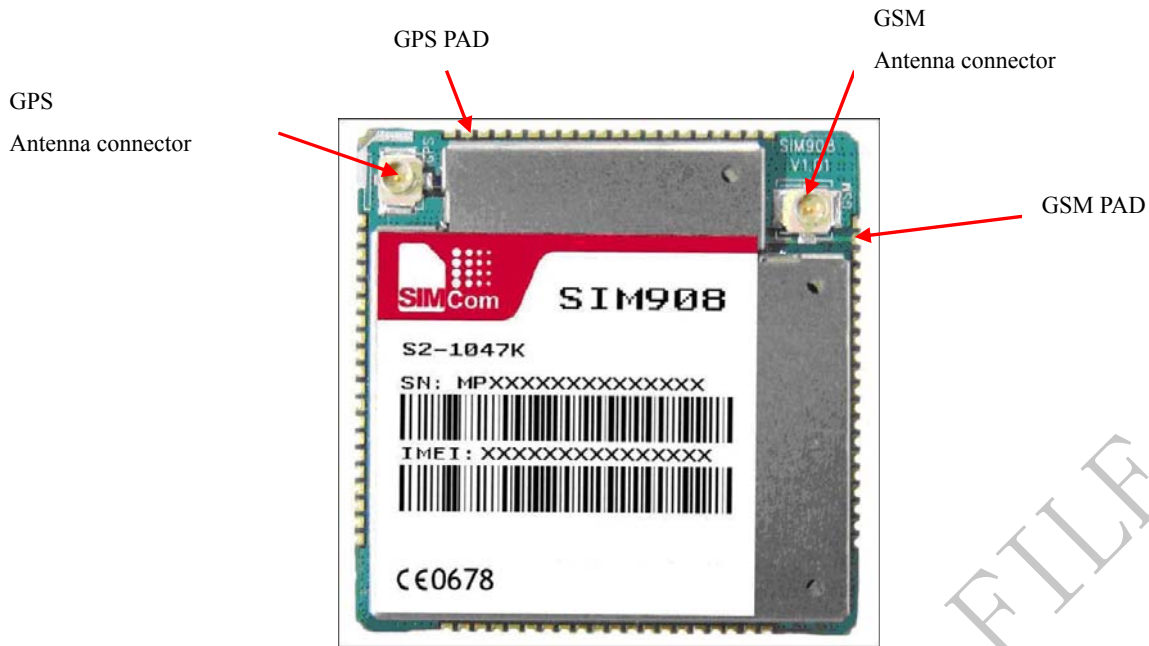

Figure 38: The RF interface of module

If the GSM RF connector is used, the customer’s main board under the antenna pad should be copper keep out. To minimize the loss on the RF cable, it need be very careful to choose RF cable. SIMCom recommends the insertion loss should be meet following requirements:

- GSM900<1dB
- DCS1800 <1.5dB

The customer’s antenna also can be located in the customer’s main board and connect to module’s antenna pad through microstrip line or other type RF trace which impedance must be controlled in 50Ω. To facilitate the antenna tuning and certification test, a RF connector and an antenna matching circuit should be added. The following figure is the recommended circuit.

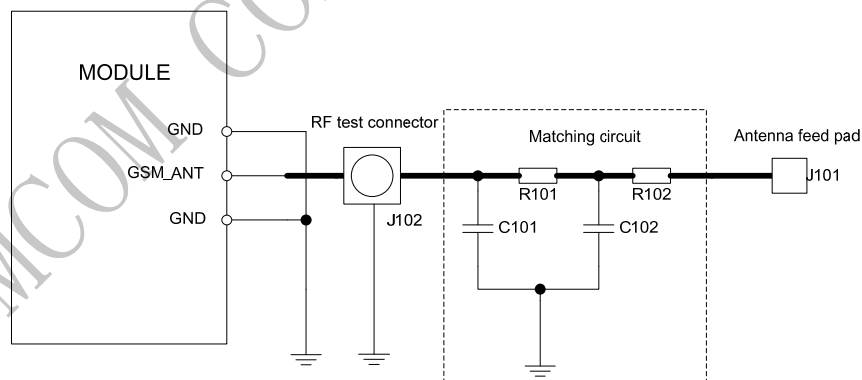

Figure 39: GSM antenna matching circuit

In this figure, the components R101,R102,C101 and C102 is used for antenna matching, the components’ value only can be got after the antenna tuning. Usually, matching components’ value is provided by antenna vendor, the default value of R101 and R102 are 0Ω, and reserve the place of C101 and C102 without soldering.

The RF test connector in figure 39 is used for conducted RF performance test, and should be placed as close as possible to the module’s RF_ANT pin. The traces in bold type should be treated as 50Ω impedance controlled line in PCB layout. For details about radio frequency trace layout, please refer to *document [9]*.

5 GPS Application Interface

SIM908 provide a high-performance L1 GPS solution for cellular handset applications. The solution offers best-in-class acquisition and tracking sensitivity, Time-To-First-Fix (TTFF) and accuracy. The GPS engine supports both fully-autonomous operations for use in handheld consumer navigation devices and other standalone navigation systems.

The GPS NMEA information is output by DEBUG port. The default baud rate is 115200bps.

The GPS engine is controlled by GSM engine, so when it is necessary to run GPS, the GSM engine must be powered on and not in SLEEP mode.

All the GPS function is controlled by AT command via serial port. The GPS function AT commands are listed in the following table.

Table 19: AT Commands for GPS function

Command	Description
AT+CGPSPWR	GPS power control
AT+CGPSRST	GPS mode reset (hot/warm/cold)
AT+CGPSSSTATUS	Get current GPS status
AT+CGPSOUT	GPS NMEA data output control
AT+CGPSINF	Get current GPS location info
AT+CGPSIPR	Set GPS NMEA output uart bps

For details of these AT command, please refer to *document [1]*.

5.1 GPS Operating Modes

GPS has two operating modes which can be controlled by AT command.

Active mode: GPS is active as a GPS receiver. The GPS engine will automatically acquire and track GPS satellites.

Power down mode: The GPS engine will be set into this mode by sending AT command "AT+CGPSPWR=0". In this mode the internal power supply for GPS will be shutdown, and the current consumption is very low. The last position, current time and ephemeris data will be stored in the GSM host memory.

5.2 GPS Power on/down Scenarios

5.2.1 Power on GPS engine

User can power on GPS engine by sending AT command “AT+CGPSPWR=1”.

5.2.2 Power down GPS engine

User can power down GPS engine by sending AT command “AT+CGPSPWR=0”.

5.3 GPS-VANT-OUT and GPS-VANT-IN

GPS-VANT-OUT is a 2.8V output for active external antenna, if the active external antenna works at 2.8V voltage supply domain, user can connect the GPS-VANT-OUT and GPS-VANT-IN directly. If the antenna's power is not 2.8V, a proper voltage should be provided to the pin GPS-VANT-IN depending on the active antenna, and the pin GPS-VANT-OUT should be kept open. For passive antennas, both the pin GPS-VANT-OUT and the pin GPS-VANT-IN should be kept open.

5.4 GPS Antenna Interface

5.4.1 GPS Antenna Interface

The RF interface has an impedance of 50Ω. To suit the physical design of individual applications, SIM908 offers alternatives

- Recommended approach: GPS RF connector
- GPS Ant pad.

If the antenna connector is used, the customer's main board under the antenna pad should be copper keep out. To minimize the loss on the RF cable, it need be very careful to choose RF cable. SIMCom recommend the insertion loss should be meet following requirements:

- GPS < 0.9dB

The customer's antenna also can be located in the customer's main board and connect to module's antenna pad through microstrip line or other type RF trace which impedance must be controlled in 50Ω. To facilitate the antenna tuning and certification test, a RF connector and an antenna matching circuit should be added. The following figure is the recommended circuit.

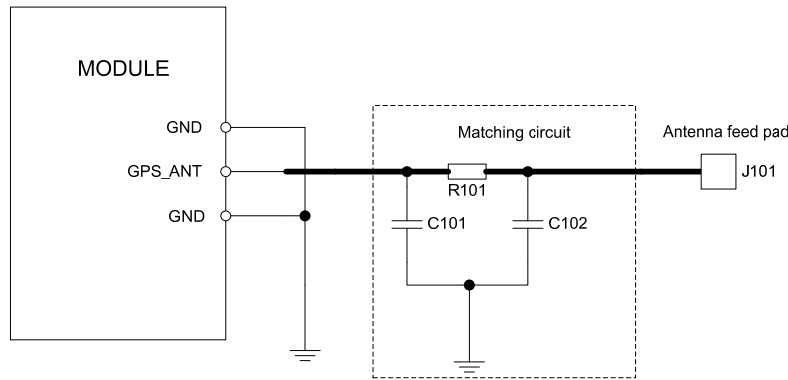

Figure 40: GPS antenna matching circuit

In this figure, the components R101, C101 and C102 is used for antenna matching, the components' value only can be got after the antenna tuning. Usually, matching components' value is provided by antenna vendor, the default value of R101 is 0Ω , and users need to reserve the place of C101 and C102 without soldering.

The traces in bold type should be treated as 50Ω impedance controlled line in PCB layout.

5.4.2 GPS Antenna Choice Consideration

To obtain excellent GPS reception performance, a good antenna will always be required. The antenna is the most critical item for successful GPS reception in a weak signal environment. Proper choice and placement of the antenna will ensure that satellites at all elevations can be seen, and therefore, accurate fix measurements are obtained.

Most customers contract with antenna design houses to properly measure the radiation pattern of the final mounted configuration in a plastic housing with associated components near the antenna. Linear antennas are becoming more popular, and the gain is reasonable, since a smaller ground plane can be used.

User can consider following factors as:

- Choose a linear antenna with a reasonably uniform hemispherical gain pattern of $>-4\text{dBi}$.
- Use of an antenna with lower gain then this will give less than desirable results. Please note that a RHCP antenna with a gain of 3dBi , equates to a linear polarized antenna of 0dBi .
- Proper ground plane sizing is a critical consideration for small GPS antennas.
- Proper placement of the GPS antenna should always be the FIRST consideration in integrating the SIM18 GPS Module.

If the customer's design will allow for a ceramic RHCP patch antenna with an appropriately sized ground plane, and the patch is normally oriented towards the sky, then that particular solution usually works the best. Note that if the patch antenna ground plane is less than $60\times 60\text{mm}$, then compromises to the beam width and gain pattern could result. Usually the gain becomes very directional, and loses several dB of performance. Since results can vary, measuring the antenna radiation pattern in the final housing in an appropriate anechoic chamber is required.

Some customers do not have the size availability to implement a patch antenna approach. In that instance, use of a Linear Polarized (LP) antenna is the next best alternative. There are new ceramic LP antennas on the market that exhibit reasonable gain characteristics once properly mounted in the housing, and when matched to an appropriate sized ground. Generally the ground plane requirements are smaller for a LP antenna when compared to a patch, but once again, proper testing in an anechoic chamber is a mandatory requirement. These ceramic elements will

need to be located near the end of the ground plane, and will require several millimeters of clearance between the closest component. It is important to note that use of a LP antenna will result in a minimum of 3dB of gain loss when compared to a RHCP antenna at a defined elevation. This is due to the right hand gain rule of antenna propagation.

Use of PIFA antenna is another LP possibility, but the PIFA usually exhibits a considerable amount of gain nulls, or “holes” in the radiation pattern. This will be undesirable for obtaining a low circular error probability (CEP), since the antenna may not allow the receiver to capture the desired satellite at the ideal orientation due to these noted gain nulls. Once again, careful testing in an appropriate anechoic chamber is required.

If the customer’s design is for automotive applications, then an active antenna can be used and located on top of the car in order for guarantee the best signal quality. GPS antenna choice should be based on the designing product and other conditions.

For detailed Antenna designing consideration, please refer to related antenna vendor’s design recommendation. The antenna vendor will offer further technical support and tune their antenna characteristic to achieve successful GPS reception performance depending on the customer’s design.

6 Electrical, Reliability and Radio Characteristics

6.1 Absolute Maximum Ratings

The absolute maximum ratings stated in following table are stress ratings under non-operating conditions. Stresses beyond any of these limits will cause permanent damage to SIM908.

Table 20: Absolute maximum ratings

Symbol	Parameter	Min	Typ	Max	Unit
V _{BAT}	Power supply voltage	-	-	5.5	V
V _I *	Input voltage	-0.3	-	3.1	V
I _I *	Input current	-	-	10	mA
I _O *	Output current	-	-	10	mA

*These parameters are for digital interface pins, such as keypad, GPIO, I²C, UART, LCD, PWMs and DEBUG.

6.2 Recommended Operating Conditions

Table 21: Recommended operating conditions

Symbol	Parameter	Min	Typ	Max	Unit
V _{BAT}	Power supply voltage	3.2	4.0	4.8	V
T _{OPER}	Operating temperature	-40	+25	+85	°C
T _{STG}	Storage temperature	-45		+90	°C

6.3 Digital Interface Characteristics

Table 22: Digital interface characteristics

Symbol	Parameter	Min	Typ	Max	Unit
I _{IH}	High-level input current	-10	-	10	uA
I _{IL}	Low-level input current	-10	-	10	uA
V _{IH}	High-level input voltage	2.4	-	-	V
V _{IL}	Low-level input voltage	-	-	0.4	V
V _{OH}	High-level output voltage	2.7	-	-	V
V _{OL}	Low-level output voltage	-	-	0.1	V

* These parameters are for digital interface pins, such as keypad, GPIO, I²C, UART, LCD, PWMs and DEBUG.

6.4 SIM Card Interface Characteristics

Table 23: SIM card interface characteristics

Symbol	Parameter	Min	Typ	Max	Unit
I _{IH}	High-level input current	-10	-	10	uA
I _{IL}	Low-level input current	-10	-	10	uA
V _{IH}	High-level input voltage	1.4	-	-	V
		2.4	-	-	V
V _{IL}	Low-level input voltage	-	-	0.4	V
		-	-	2.4	V
V _{OH}	High-level output voltage	1.7	-	-	V
		2.7	-	-	V
V _{OL}	Low-level output voltage	-	-	0.1	V
		-	-	0.1	V

6.5 VDD_EXT Characteristics

Table 24: VDD_EXT characteristics

Symbol	Parameter	Min	Typ	Max	Unit
V _O	Output voltage	2.70	2.80	2.95	V
I _O	Output current	-	-	10	mA

6.6 SIM_VDD Characteristics

Table 25: SIM_VDD characteristics

Symbol	Parameter	Min	Typ	Max	Unit
V _O	Output voltage	2.75	2.9	3.00	V
		1.65	1.80	1.95	
I _O	Output current	-	-	10	mA

6.7 VRTC Characteristics

Table 26: VRTC characteristics

Symbol	Parameter	Min	Typ	Max	Unit
V _{VRTC-IN}	VRTC input voltage	2.00	3.00	3.15	V
I _{VRTC-IN}	VRTC input current	-	2	-	uA
V _{VRTC-OUT}	VRTC output voltage	-	3.00	-	V
I _{VRTC-OUT}	VRTC output current	-	10	-	uA

6.8 Current Consumption (VBAT = 3.8V, GPS engine is powered down)

Table 27: GSM current consumption

Symbol	Parameter	Conditions	Value	Unit		
I _{VRTC}	VRTC current	VBAT disconnects. Backup battery is 3 V	2	uA		
I _{VBAT}	VBAT current	Power down mode	50	uA		
		Sleep mode	BS-PA-MFRMS=9	1.2	mA	
			BS-PA-MFRMS=5	1.5		
			BS-PA-MFRMS=2	1.7		
		Idle mode	GSM 850	21	mA	
			EGSM 900			
			DCS 1800			
			PCS 1900			
		Voice call	GSM 850 EGSM 900	PCL=5	240	mA
				PCL=12	110	
				PCL=19	76	
			DCS 1800 PCS 1900	PCL=0	180	
				PCL=7	89	
				PCL=15	76	
		Data mode GPRS(1Rx,1Tx)	GSM 850 EGSM 900	PCL=5	240	mA
PCL=12	110					
PCL=19	83					
DCS 1800 PCS 1900	PCL=0		170	mA		
	PCL=7		95			

		Data mode GPRS(4Rx,1Tx)	GSM 850 EGSM 900	PCL=15	80	mA	
				PCL=5	270		
				PCL=12	150		
			PCL=19	120			
			DCS 1800 PCS 1900	PCL=0	210		mA
				PCL=7	130		
		PCL=15		115			
		Data mode GPRS(3Rx,2Tx)	GSM 850 EGSM 900	PCL=5	435	mA	
				PCL=12	185		
				PCL=19	130		
			DCS 1800 PCS 1900	PCL=0	320	mA	
				PCL=7	155		
PCL=15	122						
I _{VBAT-peak}	Peak current	During Tx burst			2	A	

6.9 Electro-Static Discharge

SIM908 is an ESD sensitive component, so more attention should be paid to the procedure of handling and packaging. The ESD test results are shown in the following table.

Table 28: The ESD characteristics (Temperature: 25°C, Humidity: 45 %)

Pin	Contact discharge	Air discharge
VBAT	±5KV	±10KV
GND	±4KV	±10KV
RXD, TXD	±3KV	±6KV
Antenna port	±5KV	±10KV
SPKP/ SPKN MICP/ MICN	±3KV	±8KV
PWRKEY	±3KV	±8KV

6.10 Radio Characteristics

6.10.1 Module RF Output Power

The following table shows the module conducted output power, it is followed by the 3GPP TS 05.05 technical specification requirement.

Table 29: SIM908 GSM 900 and GSM 850 conducted RF output power

GSM 900 and EGSM 850			
PCL	Nominal output power (dBm)	Tolerance (dB) for conditions	
		Normal	Extreme
0-2	39	±2	±2.5
3	37	±3	±4
4	35	±3	±4
5	33	±3	±4
6	31	±3	±4
7	29	±3	±4
8	27	±3	±4
9	25	±3	±4
10	23	±3	±4
11	21	±3	±4
12	19	±3	±4
13	17	±3	±4
14	15	±3	±4
15	13	±3	±4
16	11	±5	±6
17	9	±5	±6
18	7	±5	±6
19-31	5	±5	±6

Table 30: SIM908 DCS 1800 and PCS 1900 conducted RF output power

DCS 1800 and PCS 1900			
PCL	Nominal output power (dBm)	Tolerance (dB) for conditions	
		Normal	Extreme
29	36	±2	±2.5
30	34	±3	±4
31	32	±3	±4
0	30	±3	±4
1	28	±3	±4
2	26	±3	±4
3	24	±3	±4
4	22	±3	±4
5	20	±3	±4
6	18	±3	±4
7	16	±3	±4
8	14	±3	±4
9	12	±4	±5
10	10	±4	±5

11	8	±4	±5
12	6	±4	±5
13	4	±4	±5
14	2	±5	±6
15-28	0	±5	±6

For the module’s output power, the following is should be noted:

At GSM900 and GSM850 band, the module is a class 4 device, so the module’s output power should not exceed 33dBm, and at the maximum power level, the output power tolerance should not exceed +/-2dB under normal condition and +/-2.5dB under extreme condition.

At DCS1800 and PCS1900 band, the module is a class 1 device, so the module’s output power should not exceed 30dBm, and at the maximum power level, the output power tolerance should not exceed +/-2dB under normal condition and +/-2.5dB under extreme condition.

6.10.2 Module RF Receive Sensitivity

The following table shows the module’s conducted receive sensitivity, it is tested under static condition.

Table 31: SIM908 conducted RF receive sensitivity

Frequency	Receive sensitivity (Typical)	Receive sensitivity(Max)
GSM850	-109dBm	-107dBm
EGSM900	-109dBm	-107dBm
DCS1800	-109dBm	-107dBm
PCS1900	-109dBm	-107dBm

6.10.3 Module Operating Frequencies

The following table shows the module’s operating frequency range; it is followed by the 3GPP TS 05.05 technical specification requirement.

Table 32: SIM908 operating frequencies

Frequency	Receive	Transmit
GSM850	869 ~ 894MHz	824 ~ 849 MHz
EGSM900	925 ~ 960MHz	880 ~ 915MHz
DCS1800	1805 ~ 1880MHz	1710 ~ 1785MHz
PCS1900	1930 ~ 1990MHz	1850 ~ 1910MHz

7 Manufacturing

7.1 Top View of SIM908



Figure 41: Top view of SIM908 module

7.2 Typical Solder Reflow Profile

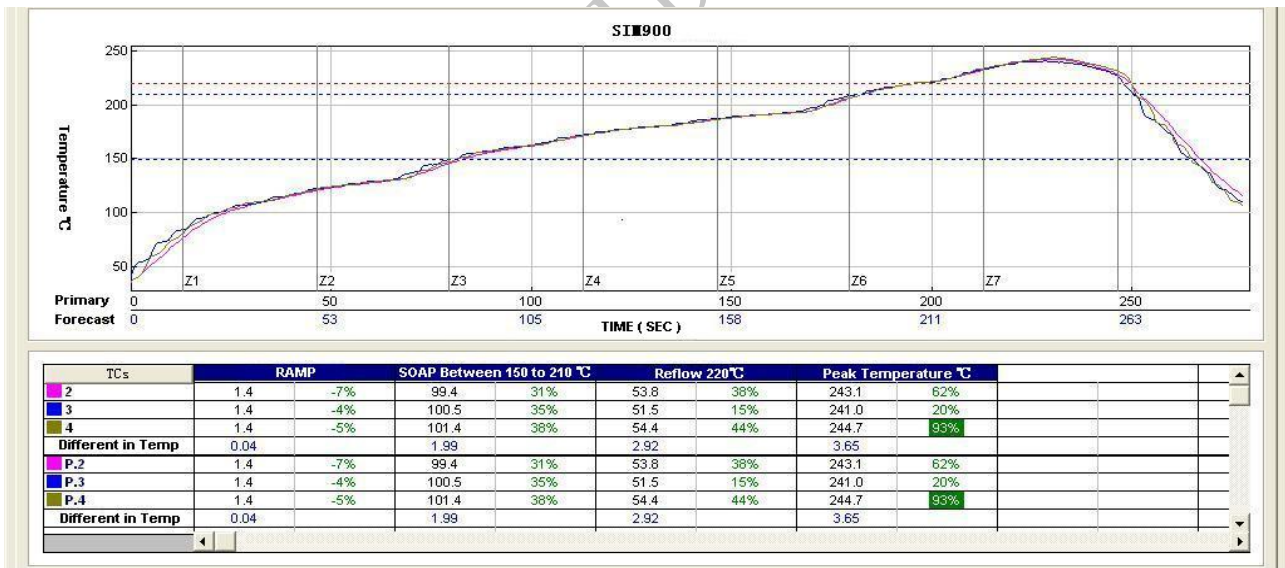

Figure 42: Typical solder reflow profile

For details about secondary SMT, please refer to *document [10]*.

7.3 Moisture Sensitivity Level (MSL)

SIM908 is qualified to MSL3 in accordance with IPC/JEDEC J-STD-033.

Appendix

A. Related Documents

Table 33: Related documents

SN	Document name	Remark
[1]	SIM908_AT Command Manual	SIM908 AT Command Manual
[2]	AN_SIM900_TCPIP	TCP/IP Applications User Manual
[3]	SIM900_Multiplexer User Manual_Application Note	SIM908 Multiplexer User Manual Application Note
[4]	AN_SIM900 Series_Update Tool_UGD	SIM908 Series Update Tool User Guide
[5]	AN_SIM900_AUDIO	Applications Note About SIM908 Audio
[6]	AN_SIM900_Audio LINE-IN input	Applications Note About SIM908 LINE-IN Input
[7]	SIM900_Embedded AT Application Note	SIM908 Embedded AT Application Note
[8]	AN_Serial Port	Application Note About Serial Port
[9]	AN_SIM900-TE PCB Layout & Schematic for Reference	Application Note About SIM908-TE PCB Layout & Schematic
[10]	Module secondary-SMT-UGD	Module secondary SMT User Guide
[11]	ITU-T Draft new recommendation V.25ter:	Serial asynchronous automatic dialing and control
[12]	GSM 07.07:	Digital cellular telecommunications (Phase 2+); AT command set for GSM Mobile Equipment (ME)
[13]	GSM 07.10:	Support GSM 07.10 multiplexing protocol
[14]	GSM 07.05:	Digital cellular telecommunications (Phase 2+); Use of Data Terminal Equipment – Data Circuit terminating Equipment (DTE – DCE) interface for Short Message Service (SMS) and Cell Broadcast Service (CBS)
[15]	GSM 11.14:	Digital cellular telecommunications system (Phase 2+); Specification of the SIM Application Toolkit for the Subscriber Identity Module – Mobile Equipment (SIM – ME) interface
[16]	GSM 11.11:	Digital cellular telecommunications system (Phase 2+); Specification of the Subscriber Identity Module – Mobile Equipment (SIM – ME) interface
[17]	GSM 03.38:	Digital cellular telecommunications system (Phase 2+); Alphabets and language-specific information
[18]	GSM 11.10	Digital cellular telecommunications system (Phase 2); Mobile Station (MS) conformance specification; Part 1: Conformance specification

B. Terms and Abbreviations







Table 34: Terms and Abbreviations

Abbreviation	Description
ADC	Analog-to-Digital Converter
AMR	Adaptive Multi-Rate
CS	Coding Scheme
CSD	Circuit Switched Data
CTS	Clear to Send
DTE	Data Terminal Equipment (typically computer, terminal, printer)
DTR	Data Terminal Ready
DTX	Discontinuous Transmission
EFR	Enhanced Full Rate
EGSM	Enhanced GSM
ESD	Electrostatic Discharge
ETS	European Telecommunication Standard
FR	Full Rate
GPRS	General Packet Radio Service
GSM	Global Standard for Mobile Communications
HR	Half Rate
IMEI	International Mobile Equipment Identity
Li-ion	Lithium-Ion
MO	Mobile Originated
MS	Mobile Station (GSM engine), also referred to as TE
MT	Mobile Terminated
PAP	Password Authentication Protocol
PBCCH	Packet Broadcast Control Channel
PCB	Printed Circuit Board
PCL	Power Control Level
PCS	Personal Communication System, also referred to as GSM 1900
PDU	Protocol Data Unit
PPP	Point-to-point protocol
RF	Radio Frequency
RMS	Root Mean Square (value)
RTC	Real Time Clock
RX	Receive Direction
SIM	Subscriber Identification Module
SMS	Short Message Service
TE	Terminal Equipment, also referred to as DTE
TX	Transmit Direction
UART	Universal Asynchronous Receiver & Transmitter

URC	Unsolicited Result Code
USSD	Unstructured Supplementary Service Data
Phonebook abbreviations	
FD	SIM fix dialing phonebook
LD	SIM last dialing phonebook (list of numbers most recently dialed)
MC	Mobile Equipment list of unanswered MT calls (missed calls)
ON	SIM (or ME) own numbers (MSISDNs) list
RC	Mobile Equipment list of received calls
SM	SIM phonebook
NC	Not connect

C. Safety Caution

Table 35: Safety caution

Marks	Requirements
	When in a hospital or other health care facility, observe the restrictions about the use of mobiles. Switch the cellular terminal or mobile off, medical equipment may be sensitive to not operate normally for RF energy interference.
	Switch off the cellular terminal or mobile before boarding an aircraft. Make sure it is switched off. The operation of wireless appliances in an aircraft is forbidden to prevent interference with communication systems. Forget to think much of these instructions may lead to the flight safety or offend against local legal action, or both.
	Do not operate the cellular terminal or mobile in the presence of flammable gases or fumes. Switch off the cellular terminal when you are near petrol stations, fuel depots, chemical plants or where blasting operations are in progress. Operation of any electrical equipment in potentially explosive atmospheres can constitute a safety hazard.
	Your cellular terminal or mobile receives and transmits radio frequency energy while switched on. RF interference can occur if it is used close to TV sets, radios, computers or other electric equipment.
	Road safety comes first! Do not use a hand-held cellular terminal or mobile when driving a vehicle, unless it is securely mounted in a holder for hands free operation. Before making a call with a hand-held terminal or mobile, park the vehicle.
	GSM cellular terminals or mobiles operate over radio frequency signals and cellular networks and cannot be guaranteed to connect in all conditions, for example no mobile fee or a invalid SIM card. While you are in this condition and need emergent help, please remember using emergency calls. In order to make or receive calls, the cellular terminal or mobile must be switched on and in a service area with adequate cellular signal strength. Some networks do not allow for emergency call if certain network services or phone features are in use (e.g. lock functions, fixed dialing etc.). You may have to deactivate those features before you can make an emergency call. Also, some networks require that a valid SIM card be properly inserted in the cellular terminal or mobile.

Contact us:

Shanghai SIMCom Wireless Solutions Ltd.

Add: SIM Technology Building, No.633, Jinzhong Road, Changning District, Shanghai P.R. China
200335

Tel: +86 21 3252 3300

Fax: +86 21 3252 3301

URL: www.sim.com/wm

SIMCOM CONFIDENTIAL FILE